



Province of the
EASTERN CAPE
EDUCATION

**NATIONAL
SENIOR CERTIFICATE**

GRADE 11

NOVEMBER 2020

**PHYSICAL SCIENCES P1
(EXEMPLAR)**

MARKS: 150

TIME: 3 hours



This question paper consists of 19 pages including 2 datasheets.

INSTRUCTIONS AND INFORMATION

1. Write your full NAME and SURNAME in the appropriate space on the ANSWER BOOK.
2. This question paper consists of TEN questions. Answer ALL the questions in the ANSWER BOOK.
3. Start EACH question on a NEW page.
4. Number the answers correctly according to the numbering system used in this question paper.
5. Leave ONE line between two sub questions, for example between QUESTION 2.1 and QUESTION 2.2.
6. You may use a non-programmable calculator.
7. You may use appropriate mathematical instruments.
8. Show ALL formulae and substitutions in ALL calculations.
9. Round off your FINAL numerical answers to a minimum of TWO decimal places.
10. Give brief motivations, discussions, et cetera where required.
11. You are advised to use the attached DATA SHEETS.
12. Write neatly and legibly.

QUESTION 1: MULTIPLE-CHOICE QUESTIONS

Four possible options are provided as answers to the following questions. Each question has only ONE correct answer. Choose the best answer and only write down (A–D) next to the question numbers (1.1–1.10) in the ANSWER BOOK, for example 1.11 D.

1.1 Which ONE of the following forces CANNOT be equal to zero?

- A Normal force
- B Frictional force
- C Gravitational force
- D Applied force

(2)

1.2 The diagram below represents four vectors Q, R, S and T.

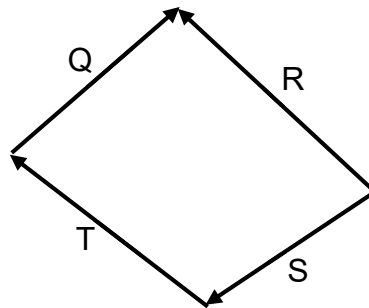

Which ONE of the vectors is the resultant of the other three vectors?

- A Q
- B R
- C S
- D T

(2)

1.3 A girl of weight 600 N is standing on a bathroom scale in a lift that is moving and she noticed that the scale reads 560 N. Which ONE of the following is the CORRECT conclusion about the motion of the lift? The lift is ...

- A accelerating upwards.
- B accelerating downwards.
- C moving upwards at constant velocity.
- D moving downwards at constant velocity.

(2)

1.4 Passengers in a moving car are advised to wear safety belts. This will reduce their chances of getting injured in the event of an accident. This precaution is an application of which ONE of the following Physics laws?

- A Newton's first law
- B Newton's second law
- C Newton's third law
- D Newton's law of universal gravitation

(2)

1.5 Which ONE of the graphs below represents the relationship between the gravitational force F between two objects and the distance r between the objects?

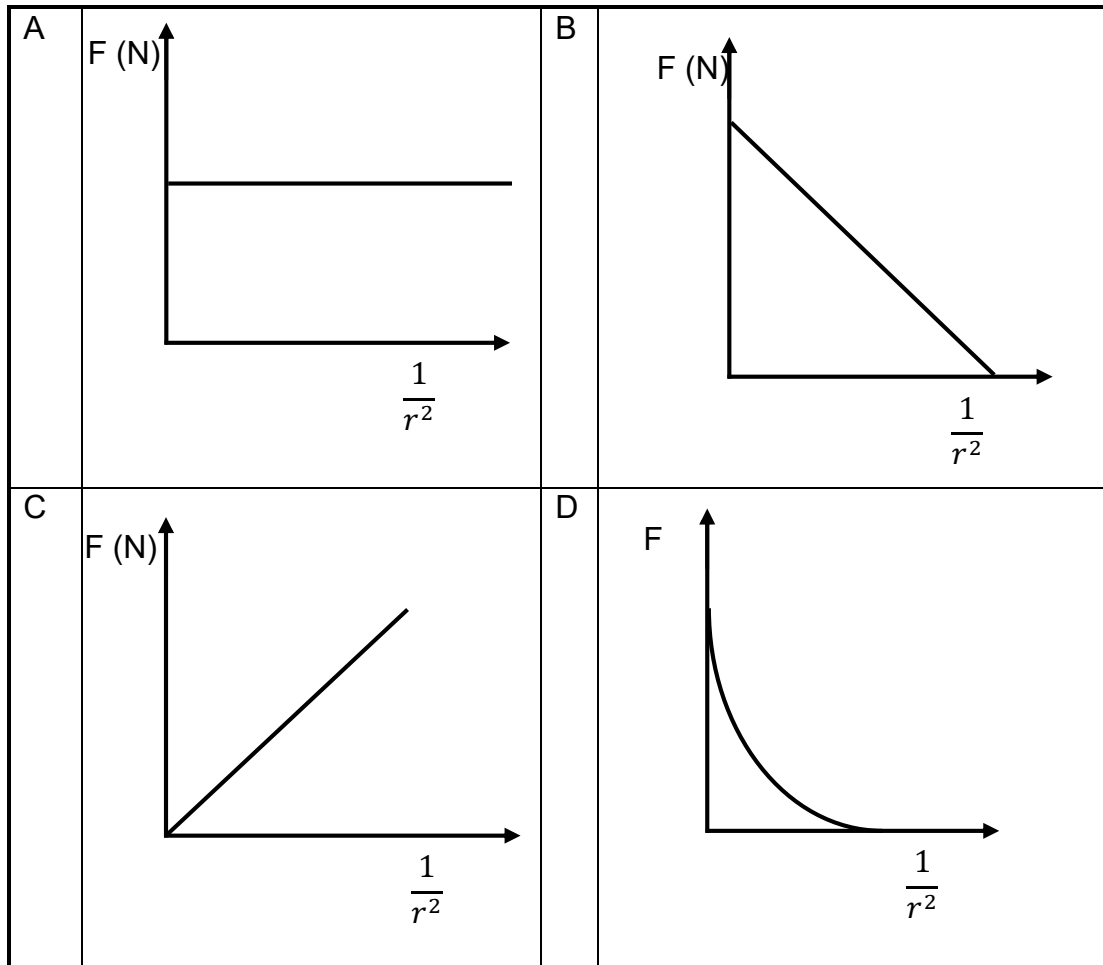

(2)

- 1.6 A light ray passes from air into a glass prism. The ray is refracted through the prism and emerges out of the prism as shown in the diagram below.

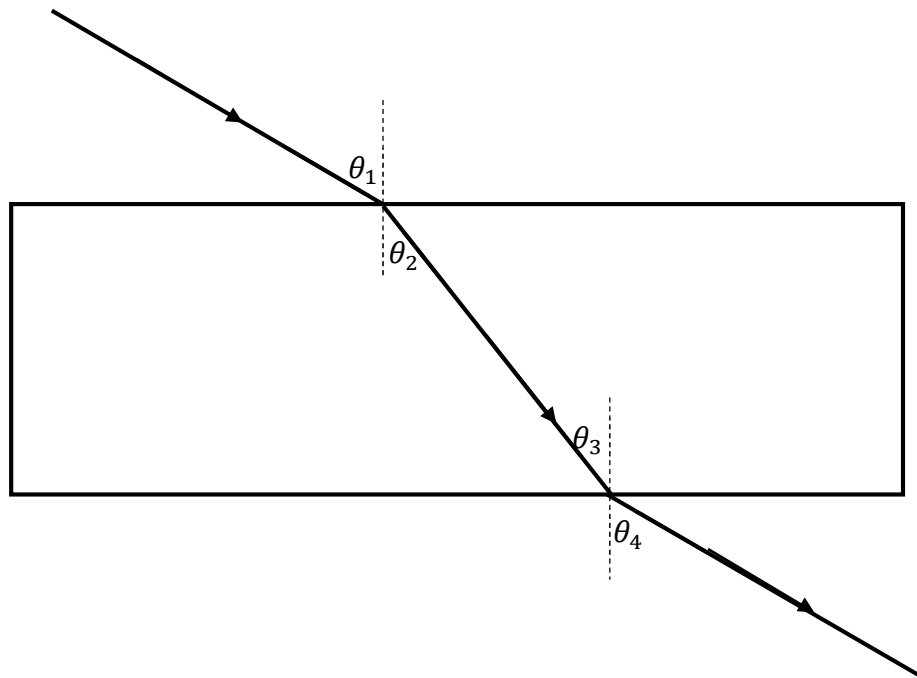

Which ONE of the following statements is TRUE regarding the diagram above?

- A $\theta_4 = \theta_3$
 - B $\theta_4 = \theta_1$
 - C $\theta_4 = \theta_2$
 - D $\theta_1 = \theta_2$
- 1.7 Every point of a wave front serves as a point source of spherical, secondary waves that move forward with the same speed as the wave. This definition represents ...
- A refraction.
 - B diffraction.
 - C wave front.
 - D Huygens' principle.

(2)

- 1.8 Two identical neutral spheres **P** and **Q** are placed on insulating stands. They are brought into contact with each other and a charged rod is brought near sphere **P** as shown on the diagram below.

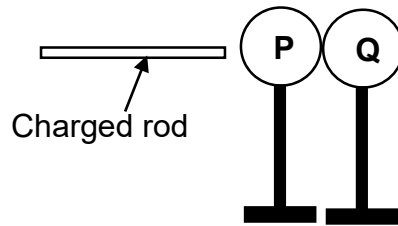

After the spheres made contact, they were separated and it was found that electrons were transferred from sphere **P** to sphere **Q**. Which ONE of the following concerning the charges on the two spheres is TRUE?

	SPHERE P	SPHERE Q
A	Positive	Positive
B	Positive	Negative
C	Negative	Negative
D	Negative	Positive

(2)

- 1.9 The magnitude of the induced emf across the ends of a loop is equal to the ...

- A radius of the loop.
- B thickness of the wire.
- C temperature of the wire.
- D rate of change the magnetic flux linkage with the wire.

(2)

1.10 In the circuit diagrams below the SAME battery and SAME IDENTICAL resistors are used. The internal resistance of the battery is ignored.

In which ONE of the following circuits will the resistors have the highest potential difference?

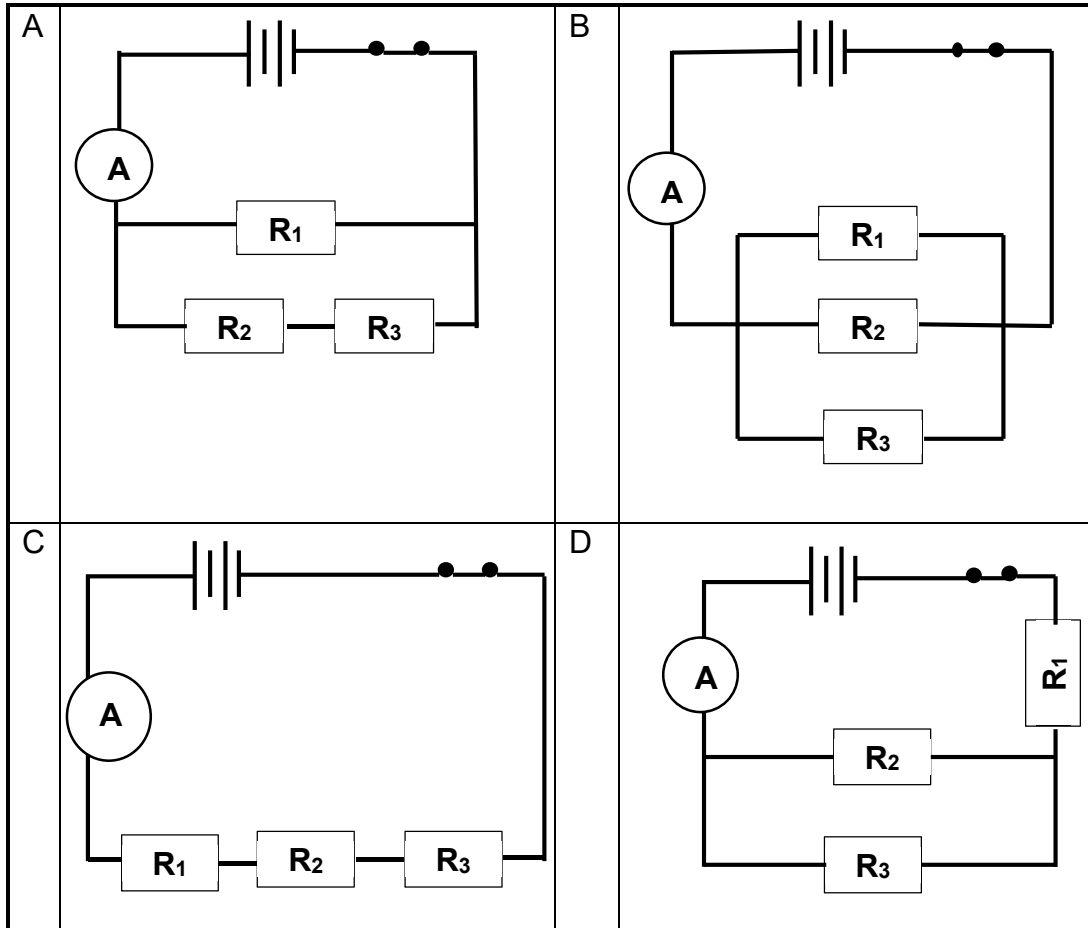

(2)
[20]

QUESTION 2

A pulley system is used to keep a crate of mass **M** kg **stationary** as shown on the diagram below.

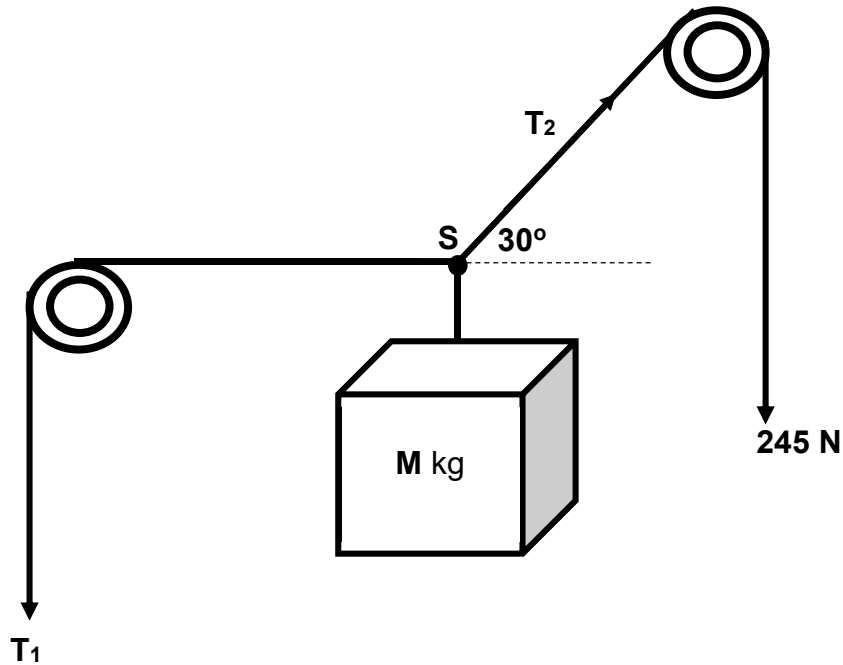

2.1 Define the term *resultant vector*. (2)

2.2 Calculate the:

2.2.1 Vertical and horizontal components of T_2 (4)

2.2.2 Magnitude of T_1 (2)

2.2.3 Mass M of the crate (3)

[11]

QUESTION 3

A 250 N force is applied on a block of mass 25 kg. The 25 kg block is connected to a 10 kg block by a light inextensible string through a frictionless pulley as shown on the diagram below. The 250 N force acts at an angle of 25° to the horizontal so that the system of blocks accelerates to the left. The coefficient of kinetic frictional force between the 25 kg block and the surface is 0,15.

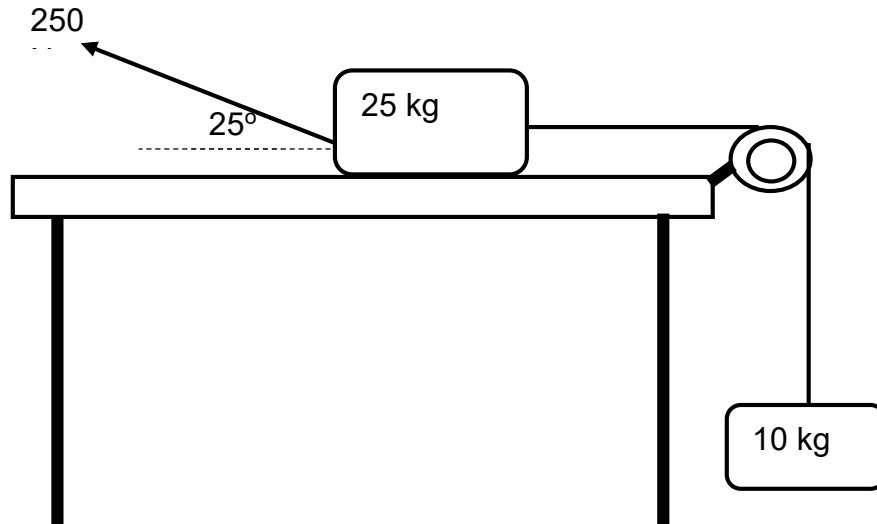

- 3.1 Define the term *kinetic frictional force*. (2)
- 3.2 Draw a labelled free-body diagram of all forces acting on the 25 kg block. (5)
- 3.3 Calculate the:
- 3.3.1 Normal force exerted by the surface on the 25 kg block (3)
- 3.3.2 Acceleration of the system of blocks (7)

[17]

QUESTION 4

Two blocks of masses 1,5 kg and 3,2 kg are connected by a light inextensible string. A 24 N force is applied on a system of blocks to move them up an inclined surface which is 25° to the horizontal at a **CONSTANT VELOCITY** as shown on the diagram below.

The 1,5 kg box experiences a constant frictional force of 2 N as it moves up the incline.

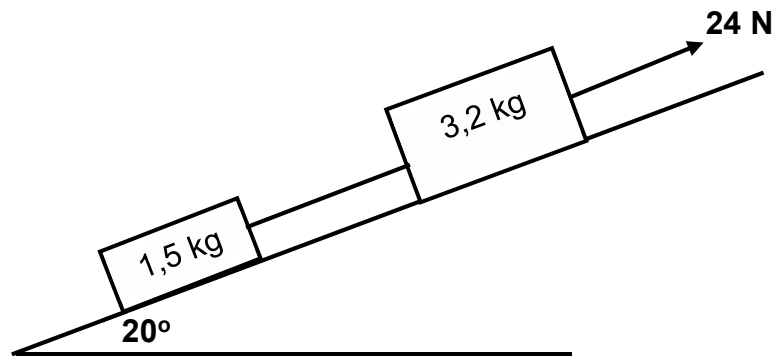

- 4.1 State Newton's Second Law of Motion in words. (2)
- 4.2 Draw a labelled free-body diagram of all forces acting on the 1,5 kg block. (4)
- 4.3 Calculate the:
- 4.3.1 Tension in the string connecting the blocks (5)
- 4.3.2 Coefficient of kinetic frictional force between the 3,2 kg block and the surface (6)

[17]

QUESTION 5

A satellite of mass 1 000 kg is orbiting the earth at a distance of 200 km from the surface of the earth as shown on the diagram below.

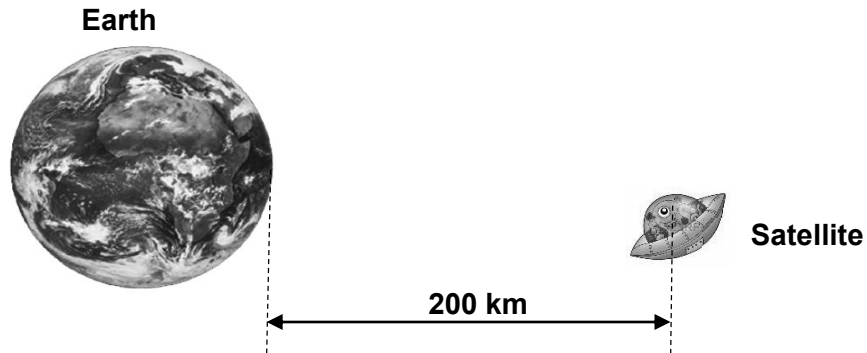

- 5.1 State Newton's Law of Universal Gravitation in words. (2)
- 5.2 Calculate the magnitude of the force that the earth exerts on the satellite to keep it in orbit. (5)
- 5.3 Calculate the weight of the satellite on the earth surface. (3)
- 5.4 The same satellite is now orbiting the earth at a distance twice the radius of the earth from the centre of the earth. Without any further calculations, determine the force that the earth exerts on the satellite at the new distance. Explain how you arrived at your answer. (3)

[13]

QUESTION 6

A light ray from a ray box is incident on a rectangular glass prism and the path of the incident ray and emergent ray was traced to obtain the diagram below. The refractive index of air and the refractive index of a glass are 1,00 and 1,52 respectively.

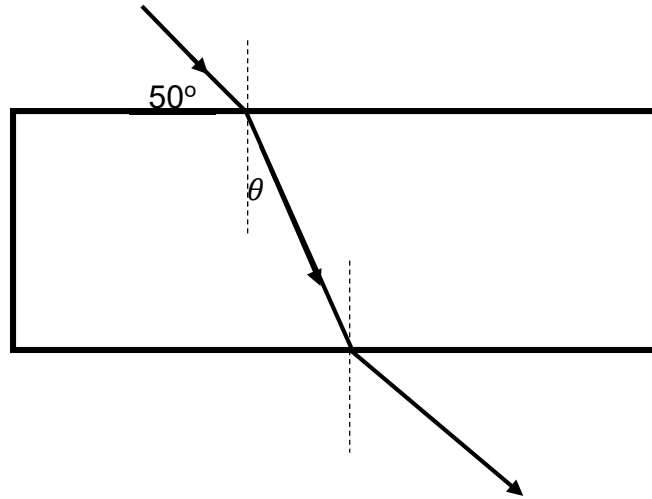

- 6.1 State Snell's law in words. (2)
- 6.2 Calculate the:
- 6.2.1 Angle θ , on the diagram (4)
- 6.2.2 Speed of light in glass (3)
- 6.2.3 Critical angle for glass (4)
- 6.3 Define total *internal reflection*. (2)
- 6.4 State TWO conditions necessary for total internal reflection to occur. (2)

[17]

QUESTION 7

A learner is investigating a certain phenomenon of light. He viewed red light through a single slit and observed the pattern that was formed on a screen. He repeated the experiment using blue light and observed the pattern on a screen again.

- 7.1 Name the phenomenon that the learner is investigating. (1)
- 7.2 Draw separate diagrams for the patterns for red light and blue light that the learner observed on the screen. Label clearly red and blue bands. (4)
- 7.3 Explain the differences observed in the patterns for red and blue light. (2)
- 7.4 Which nature of light does the phenomenon investigated demonstrate? (1)
- 7.5 What are the changes, if any, that the learner will observe if the slit width is made smaller? Explain your answer. (3)

[11]

QUESTION 8

Two identical point charges are placed 100 mm apart in a vacuum as shown below. The electrostatic force that Q_1 exerts on Q_2 is 5,09 N.



8.1 Draw the electric field pattern between the two charges. (3)

8.2 Calculate the magnitude of each charge. (4)

8.3 Calculate the net electric field at point **P**, as shown on the diagram below.

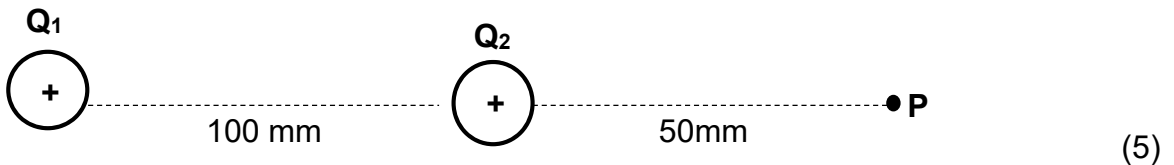

8.4 A third charge Q_3 of magnitude $5 \mu\text{C}$ is now placed at point **P** as shown in the diagram below.

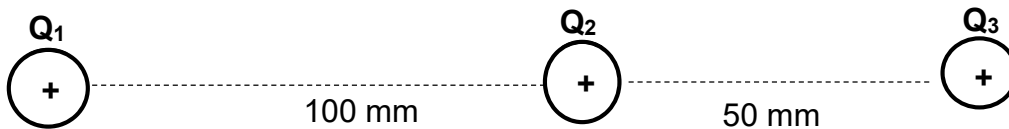

Calculate the net electrostatic force experienced by point charge Q_2 due to point charge Q_1 and Q_3 .

(5)
[17]

QUESTION 9

- 9.1 The diagram below represents a current-carrying conductor. Draw the magnetic field pattern around this conductor.



(2)

- 9.2 A solenoid with a radius of 5 cm and 350 turns is pulled out of a magnetic field of strength 5,20 T in 0,1 second. The solenoid is placed perpendicular to the magnetic field.

9.2.1 State Faraday's law in words. (2)

9.2.2 Calculate the magnetic flux linkage (Φ) with the solenoid. (3)

9.2.3 Calculate the induced emf in the solenoid. (3)

[10]

QUESTION 10

- 10.1 A learner sets up the circuit below to investigate the relationship between current and potential difference across the ends of a conductor. She closes the switch and records the ammeter and voltmeter readings. She repeats the experiment three times; each time she increases the number of cells in the circuit. Then she reads and records the ammeter and voltmeter readings.

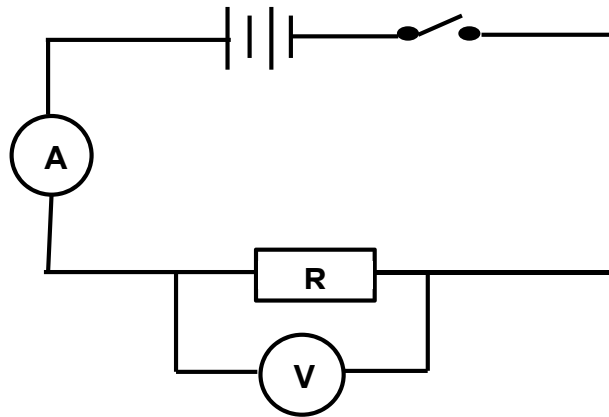

A graph of her results is shown below.

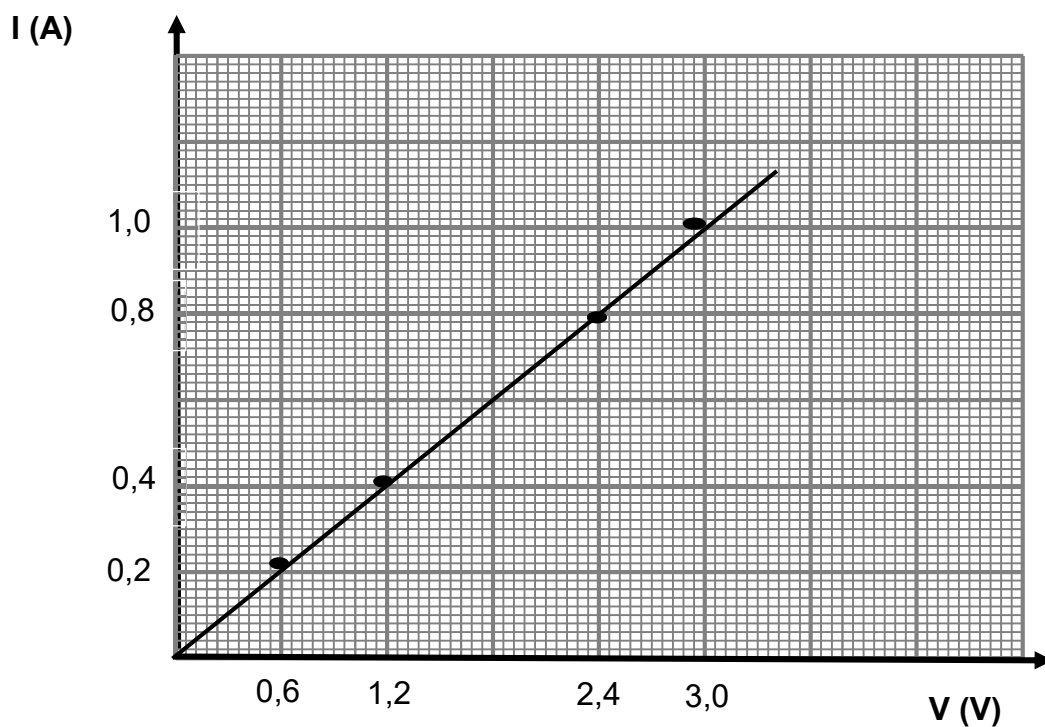

- 10.1.1 Which physical quantity does the gradient of the graph represent? (1)
- 10.1.2 Use the information from the graph to calculate the resistance of the resistor that the learner used in the investigation. (3)

- 10.2 The battery in the circuit diagram below has negligible internal resistance. The resistance of resistor **R** is unknown. When the switch is closed, the voltmeter reads 15 V and the ammeter A_1 reads 1 A.

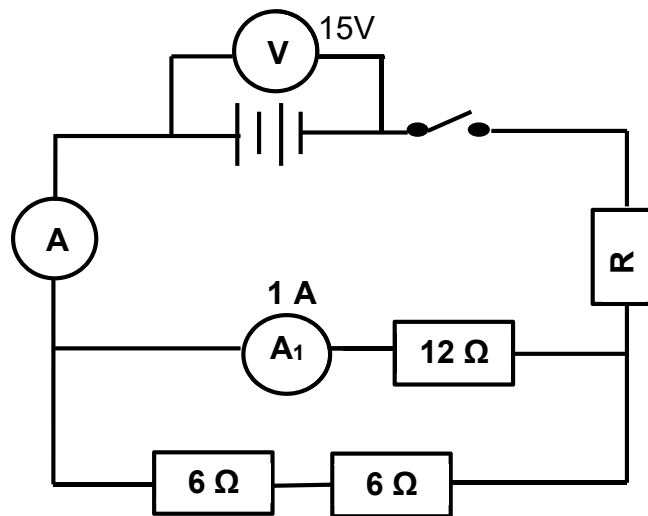

Calculate the:

- 10.2.1 Current in ammeter A (3)
- 10.2.2 Resistance of resistor R (5)
- 10.3 The resistor **R** of unknown resistance is now removed from the circuit. How will this change in the circuit affect the reading of the ammeter A?
Answer INCREASE, DECREASE or REMAIN THE SAME. Explain your answer. (2)
- 10.4 The power rating on an electric stove is 1 500 W. If the stove is used for 3 hours and 30 minutes, calculate how much it will cost to use the stove. 1 unit of electricity (1 kWh of electricity) costs R1,15. (3)

[17]

TOTAL: 150

DATA FOR PHYSICAL SCIENCES GRADE 11
PAPER 1 (PHYSICS)
GEGEWENS VIR FISIESTE WETENSKAPPE GRAAD 11
VRAESTEL 1 (FISIKA)

TABLE 1: PHYSICAL CONSTANTS/TABEL 1: FISIESTE KONSTANTES

NAME/NAAM	SYMBOL/ SIMBOOL	VALUE/WAARDE
Acceleration due to gravity / <i>Swaartekragversnelling</i>	g	9,8 m•s ⁻²
Universal gravitational constant / <i>Universelegravitasiekonstant</i>	G	6,67 × 10 ⁻¹¹ N•m ² •kg ⁻²
Speed of light in a vacuum / <i>Spoed van lig in 'n vakuüm</i>	c	3,0 × 10 ⁸ m•s ⁻¹
Planck's constant / <i>Planck se konstante</i>	h	6,63 × 10 ⁻³⁴ J•s
Coulomb's constant / <i>Coulomb se konstante</i>	k	9,0 × 10 ⁹ N•m ² •C ⁻²
Charge on electron / <i>Lading op elektron</i>	e	-1,6 × 10 ⁻¹⁹ C
Electron mass / <i>Elektronmassa</i>	m _e	9,11 × 10 ⁻³¹ kg
Mass of earth / <i>Massa op aarde</i>	M	5,98 × 10 ²⁴ kg
Radius of earth / <i>Radius van aarde</i>	R _E	6,38 × 10 ³ km

TABLE 2: FORMULAE/TABEL 2: FORMULES

MOTION/BEWEGING

$v_f = v_i + a \Delta t$	$\Delta x = v_i \Delta t + \frac{1}{2} a \Delta t^2$ or/of $\Delta y = v_i \Delta t + \frac{1}{2} a \Delta t^2$
$v_f^2 = v_i^2 + 2a\Delta x$ or/of $v_f^2 = v_i^2 + 2a\Delta y$	$\Delta x = \left(\frac{v_i + v_f}{2} \right) \Delta t$ or/of $\Delta y = \left(\frac{v_i + v_f}{2} \right) \Delta t$

FORCE/KRAG

$F_{\text{net}} = ma$	$w = mg$
$F = \frac{Gm_1 m_2}{d^2}$	$\mu_s = \frac{f_s^{\text{max}}}{N}$
$\mu_k = \frac{f_k}{N}$	

WAVES, SOUND AND LIGHT/GOLWE, KLANK EN LIG

$F = \frac{kQ_1Q_2}{r^2}$ ($k = 9,0 \times 10^9 \text{ N.m}^2.\text{C}^{-1}$)	$E = \frac{F}{q}$
$E = \frac{kQ}{r^2}$ ($k = 9,0 \times 10^9 \text{ N.m}^2.\text{C}^{-1}$)	$n = \frac{Q}{q_e}$

ELECTROMAGNETISM/ ELEKTROMAGNETISME

$\varepsilon = -N \frac{\Delta\Phi}{\Delta t}$	$\Phi = BA \cos \theta$
--	-------------------------

ELECTRIC CIRCUITS/ELEKTRIESE STROOMBANE

$I = \frac{q}{\Delta t}$	$R = \frac{V}{I}$
$\frac{1}{R_p} = \frac{1}{R_1} + \frac{1}{R_2} + \dots$	$R_s = R_1 + R_2 + \dots$
$W = Vq$ $W = VI\Delta t$ $W = I^2R\Delta t$ $W = \frac{V^2\Delta t}{R}$	$P = \frac{W}{\Delta t}$ $P = VI$ $P = I^2R$ $P = \frac{V^2}{R}$



Province of the
EASTERN CAPE
EDUCATION

**NATIONAL/NASIONALE
SENIOR
CERTIFICATE/SERTIFIKAAT**

GRADE/GRAAD 11

NOVEMBER 2020

**PHYSICAL SCIENCES P1/
FISIESE WETENSKAPPE V1
MARKING GUIDELINE/NASIENRIGLYN
(EXEMPLAR/EKSEMPLAAR)**

MARKS/PUNTE: 150

This marking guideline consists of 10 pages.
Hierdie nasienriglyn bestaan uit 10 bladsye.

QUESTION 1/VRAAG 1

- 1.1 C ✓✓ (2)
- 1.2 B ✓✓ (2)
- 1.3 A ✓✓ (2)
- 1.4 A ✓✓ (2)
- 1.5 D ✓✓ (2)
- 1.6 C ✓✓ (2)
- 1.7 D ✓✓ (2)
- 1.8 B ✓✓ (2)
- 1.9 D ✓✓ (2)
- 1.10 B ✓✓ (2)

[20]**QUESTION 2/VRAAG 2**

- 2.1 The vector sum of two or more vectors. ✓✓
Die som van twee of meer vektore.

OR/OF

A single vector having the same effect as two or more vectors acting together. ✓✓

'n Enkele vektor wat dieselfde effek het as twee of meer vektore wat saam inwerk.

(2)

- 2.2 2.2.1

OPTION 1/ OPSIE 1	OPTION 2/ OPSIE 2
$T_{2X} = T \cos \theta$	$T_{2X} = T \sin \theta$
$T_{2X} = 245 \cos 30^\circ \checkmark$	$T_{2X} = 245 \sin 60^\circ \checkmark$
$T_{2X} = 212,18 \text{ N} \checkmark$	$T_{2X} = 212,18 \text{ N} \checkmark$
$T_{2Y} = T \sin \theta$	$T_{2Y} = T \cos \theta$
$T_{2Y} = 245 \sin 30^\circ \checkmark$	$T_{2Y} = 245 \cos 60^\circ \checkmark$
$T_{2Y} = 122,5 \text{ N} \checkmark$	$T_{2Y} = 122,5 \text{ N} \checkmark$

(4)

- 2.2.2 $T_1 = T_{2X} \checkmark$
 $T_1 = 212,18 \text{ N} \checkmark$

(2)

- 2.2.3 $W = T_{2Y}$
 $W = 122,5 \text{ N}$
 $W = mg$
 $122,5 = m \times 9,8 \checkmark$
 $m = 12,5 \text{ kg} \checkmark$

Any one/Enige een ✓

(3)

[11]

QUESTION 3/VRAAG 3

3.1 The force that opposes the motion of a moving object relative to the surface. ✓✓
 Die krag wat die beweging van 'n bewegende voorwerp relatief tot die oppervlak teenwerk. (2)

3.2 **OPTION 1/OPSIE 1**

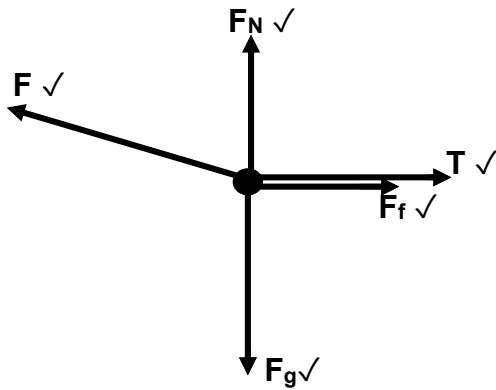

OPTION 2/OPSIE 2

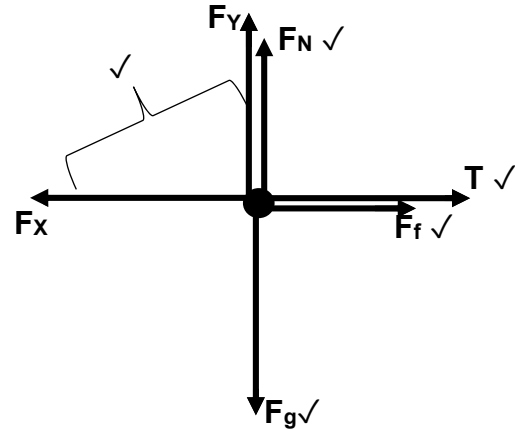

Mark awarded for arrow and label./ Punt toegeken vir byskrif en pyltjie.
 Do not penalise for length of arrows since drawing is not drawn to scale./
 Moenie vir die lengte van die pyltjie penaliseer nie aangesien diagram nie volgens skaal geteken is nie.

Any other additional force(s)/ Enige ander addisionele krag(te). $\frac{4}{5}$

If force(s) do not make contact with body. / As krag(te) nie kontak met die voorwerp maak nie. Max./ Maks. $\frac{4}{5}$ (5)

3.3 3.3.1

OPTION 1/OPSIE 1	OPTION 2/OPSIE 2
$N = F_g - F \sin \theta$ ✓ $N = 25 \times 9,8 - 250 \sin 25^\circ$ ✓ $N = 139,35 \text{ N}$ ✓	$F_Y = F \sin \theta$ $= 250 \sin 25^\circ$ $= 105,66 \text{ N}$ $N = F_g - F_Y$ ✓ $N = 25 \times 9,8 - 105,66$ ✓ $N = 139,34 \text{ N}$ ✓

(3)

3.3.2 POSITIVE MARKING FROM 3.1.1/POSITIEWE NASIEN VANAF 3.1.1

$$\left. \begin{aligned} F_{\text{net}} &= ma \\ F_{\text{net}} &= F \cos \theta - T - f \end{aligned} \right\} \text{Any one/Enige een } \checkmark$$

$$[250 \cos 25^\circ \checkmark - T - (0,15 \times 139,35) \checkmark] \checkmark = 25a$$

$$25a = 205,6744468 - T \dots (1)$$

$$F_{\text{net}} = T - F_g$$

$$T - 98 \checkmark = 10a \dots (2)$$

Adding the two equations/Tel die twee vergelykings bymekaar:

$$35a = 107,6744468$$

$$a = 3,08 \text{ m.s}^{-2} \checkmark$$

Any one of 25a or 10a/
 Enige een van 25a of 10a ✓

(7)
[17]

QUESTION 4/VRAAG 4

4.1 When a resultant force acts on an object, the object will accelerate in the direction of the force. The acceleration is directly proportional to the resultant force ✓ and inversely proportional to the mass ✓ of the object.

Wanneer 'n resulterende krag op 'n voorwerp inwerk, sal die voorwerp in die rigting van die krag versnel. Die versnelling is direk eweredig aan die resulterende krag en omgekeerd eweredig aan die massa van die voorwerp. (2)

4.2

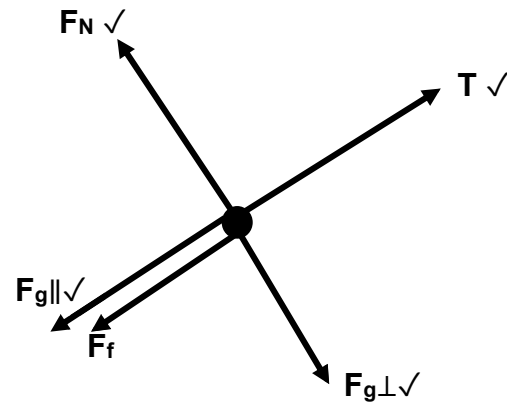
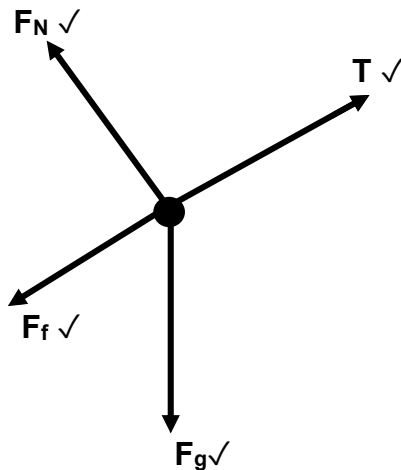

(4)

Mark awarded for arrow and label. / Punt toegeken vir pyltjie en byskrif.

Do not penalise for length of arrows since drawing is not drawn to scale. / Moenie vir die lengte van die pyltjie penaliseer nie aangesien diagram nie volgens skaal geteken is nie.

Any other additional force(s). / Enige ander addisionele krag(te). $\frac{3}{4}$

If force(s) do not make contact with body. / As krag(te) nie kontak maak met die voorwerp nie. Max/ Maks $\frac{3}{4}$

4.3 4.3.1

$$\left. \begin{aligned} F_{\text{net}} &= ma \\ F_{\text{net}} &= T - F_{g\parallel} - f \\ T - F_{g\parallel} - f &= ma \\ T - F_{g\parallel} - f &= 0 \end{aligned} \right\} \text{Any one/Enige een } \checkmark$$

$$[T - (1,5 \times 9,8 \sin 20^\circ) - 2] = 0 \checkmark$$

$$T = 7,03 \text{ N } \checkmark$$

(5)

4.3.2

$$\left. \begin{aligned} F_{\text{net}} &= ma \\ F_{\text{net}} &= F - T - F_{g\parallel} - f \\ F - T - F_{g\parallel} - f &= ma \\ F - T - F_{g\parallel} - f &= 0 \end{aligned} \right\} \text{Any one/ Enige een } \checkmark$$

$$[24 - 7,03 - (3,2 \times 9,8 \sin 20^\circ) - f_k] = 0 \checkmark$$

$$f_k = 6,22425 \text{ N}$$

$$f_k = \mu_k N \checkmark$$

$$[6,22425 = \mu_k \times 3,2 \times 9,8 \cos 20^\circ] \checkmark$$

$$\mu_k = 0,21 \checkmark$$

(6)

[17]

QUESTION 5/VRAAG 5

- 5.1 Every particle attracts every other particle in the universe with a gravitational force that is directly proportional to the product of their masses and inversely proportional to the square of the distance between their centres. ✓✓

Elke deeltjie lok enige ander deeltjie in die heelal met 'n gravitasiekrag wat direk eweredig is aan die produk van hul massas en omgekeerd eweredig is aan die kwadraat van die afstand tussen hul middelpunte.

(2)

5.2 $F = \frac{GM_1M_2}{r^2}$ ✓

$$F = \frac{6,67 \times 10^{-11} \times 5,98 \times 10^{24} \times 1000}{(6,38 \times 10^6 + 2 \times 10^5)^2}$$
 ✓✓

$$F = 9\,212,45 \text{ N}$$
 ✓

(5)

- 5.3

OPTION 1 / OPSIE 1	OPTION 2 / OPSIE 2
$W = mg$ ✓ $W = 1\,000 \times 9,8$ ✓ $W = 9\,800 \text{ N}$ ✓	$W = \frac{GM_1M_2}{r^2}$ ✓ $W = \frac{6,67 \times 10^{-11} \times 1000 \times 5,98 \times 10^{24}}{(6,38 \times 10^6)^2}$ ✓ $W = 9\,799,09 \text{ N}$ ✓

(3)

5.4 $W = \frac{900}{4}$ ✓ = 2 450 N ✓

When the distance doubles the force will decrease by a factor of 4 ✓.

Wanneer die afstand verdubbel, sal die krag vier (4) keer verminder.

(3)

[13]**QUESTION 6/VRAAG 6**

- 6.1 The ratio of the sine of the angle of incidence in one medium to the sine of the angle of refraction in the other medium is constant. ✓✓

Die verhouding tussen die sinus van die invalshoek in die een medium en die sinus van die brekingshoek in die ander medium is konstant.

(2)

6.2 6.2.1 $\frac{n_2}{n_1} = \frac{\sin\theta_1}{\sin\theta_2}$ ✓

$$\frac{1,52}{1} = \frac{\sin 40^\circ}{\sin\theta_2}$$
 ✓

$$\theta_2 = 25,02^\circ$$
 ✓

(4)

6.2.2 $n = \frac{c}{v}$ ✓

$$1,52 = \frac{3 \times 10^8}{v}$$
 ✓

$$v = 1,97 \times 10^8 \text{ m.s}^{-1}$$
 ✓

(3)

$$6.2.3 \quad \frac{n_2}{n_1} = \frac{\sin\theta_1}{\sin\theta_2} \checkmark$$

$$\frac{1,52}{1} = \frac{\sin 90^\circ}{\sin\theta_2} \checkmark$$

$$\theta_2 = 41,14^\circ \checkmark$$

(4)

- 6.3 A phenomenon that occurs when light travels from a denser medium to a less dense medium and the refracted ray does not emerge from the medium, but is reflected back into the medium. $\checkmark\checkmark$

'n Verskynsel wat voorkom wanneer lig van 'n digter medium na 'n minder digte medium beweeg en die gebreekte straal nie uit die medium kom nie, maar weer terug in die medium weerkaats.

(2)

- 6.4 The light must travel from a denser medium to a less dense medium. \checkmark
The angle of incidence must be greater than the critical angle of the denser medium. \checkmark

*Die lig moet van 'n digter medium na 'n minder digte medium beweeg.
Die invalshoek moet groter wees as die grenshoek van die digter medium.*

(2)

[17]**QUESTION 7/VRAAG 7**

- 7.1 Diffraction/ *Diffraksie* \checkmark

(1)

7.2

 $\checkmark\checkmark$ $\checkmark\checkmark$

(4)

- 7.3 The coloured bands for red light are broader than those of blue light. \checkmark
The wavelength for red light is longer than that of a blue light. \checkmark
*Die gekleurde bande vir rooi lig is breër as dié van blou lig.
Die golflengte vir rooi lig is langer as dié van blou lig.*

(2)

- 7.4 Light has a wave nature / *Lig het golf-aard* \checkmark

(1)

7.5 The coloured bands will become broader./ Die gekleurde bande sal breër word. ✓

The slit width is inversely proportional to the degree of diffraction. ✓✓
Die spleetwydte is omgekeerd eweredig aan die mate van diffraksie.

OR/OF

Smaller width gives broader diffraction./ Kleiner breedte gee breër diffraksie. ✓✓ (3)

[11]

QUESTION 8/VRAAG 8

8.1

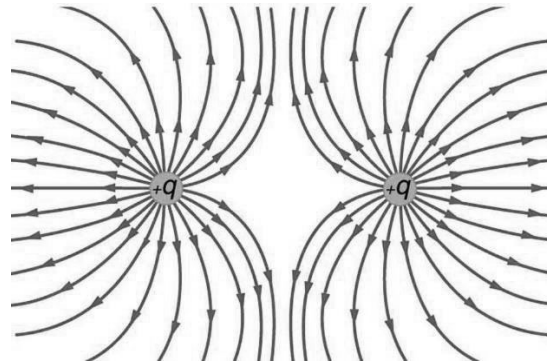

CRITERIA FOR MARKING/ KRITERIA VIR NASIEN	
Correct shape/ Korrekte vorm.	✓
Direction of field lines./ Rigting van veldlyne	✓
Field lines not crossing each other./ Veldlyne kruis nie mekaar nie.	✓

(3)

8.2 $F = \frac{kQ_1Q_2}{r^2}$ ✓

$$5,09 \checkmark = \frac{9 \times 10^9 \times Q^2}{0,1^2} \checkmark$$

$$Q = 2,38 \times 10^{-6} \text{ C} \checkmark$$

(4)

8.3 $E = \frac{kQ}{r^2}$ ✓

$$E_1 = \frac{9 \times 10^9 \times 2,38 \times 10^{-6}}{0,15^2} \checkmark$$

$$E_1 = 952\,000 \text{ NC}^{-1} \text{ right / regs}$$

$$E_2 = \frac{9 \times 10^9 \times 2,38 \times 10^{-6}}{0,05^2} \checkmark$$

$$E_2 = 8\,568\,000 \text{ NC}^{-1} \text{ right / regs}$$

$$E_{\text{net}} = E_1 + E_2$$

$$E_{\text{net}} = 952\,000 + 8\,568\,000 \checkmark$$

$$E_{\text{net}} = 9\,520\,000 \text{ NC}^{-1} \text{ right / regs} \checkmark$$

(5)

$$8.4 \quad F = \frac{kQ_1Q_2}{r^2} \quad \checkmark$$

$$F_1 = \frac{9 \times 10^9 \times 2,38 \times 10^{-6} \times 2,38 \times 10^{-6}}{0,1^2} \quad \checkmark$$

$$F_1 = 5,10 \text{ N right}$$

$$F_2 = \frac{9 \times 10^9 \times 2,38 \times 10^{-6} \times 2,38 \times 10^{-6}}{0,05^2} \quad \checkmark$$

$$F_2 = 42,84 \text{ N left / links}$$

$$F_{\text{net}} = F_1 + F_2$$

$$F_{\text{net}} = 42,84 - 5,10 \quad \checkmark$$

$$F_{\text{net}} = 37,74 \text{ N left / links} \quad \checkmark$$

(5)
[17]**QUESTION 9/VRAAG 9**

9.1

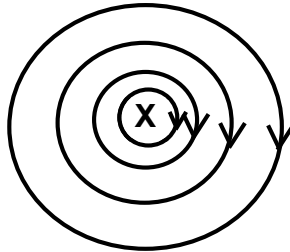
**CRITERIA FOR MARKING/ KRITERIA VIR NASIEN**

Circular shape/ Korrekte vorm

✓

Field direction/ Veldrigting

✓

(2)

9.2 9.2.1 The magnitude of the induced emf across a conductor is directly proportional to the rate of change in the magnetic flux linkage with the conductor. ✓✓

Die grootte van die geïnduseerde emk oor die geleier is direk eweredig aan die tempo van verandering in die magnetiese vloed met die geleier.

(2)

$$9.2.2 \quad \left. \begin{aligned} \Phi &= B A \cos \theta \\ \Phi &= B (\pi r^2) \cos \theta \\ \Phi &= 3,5 (\pi \times 0,05^2) \cos 0^\circ \quad \checkmark \\ \Phi &= 0,03 \text{ Wb} \quad \checkmark \quad (0,027 \text{ Wb}) \end{aligned} \right\}$$

Any one/Enige een ✓

(3)

$$9.2.3 \quad \varepsilon = \frac{-N\Delta\Phi}{\Delta t} \quad \checkmark$$

$$\varepsilon = \frac{-350(0 - 0,03)}{0,1} \quad \checkmark$$

$$\varepsilon = 105 \text{ V} \quad \checkmark$$

(3)

[10]

QUESTION 10/VRAAG 10

10.1 10.1.1 The inverse of the resistance / Die omgekeerde van die weerstand

$$\text{OR/ OF } \frac{1}{R} \checkmark$$

(1)

10.1.2

OPTION 1/ OPSIE 1	OPTION 2/ OPSIE 2
Gradient/ Gradiënt = $\frac{\Delta I}{\Delta V}$	$R = \frac{V}{I} \checkmark$
Gradient/ Gradiënt = $\frac{1,0-0,2}{3,0-0,6} \checkmark$	$R = \frac{3,0}{1,0} \checkmark$
Gradient/ Gradiënt = $\frac{1}{3}$	$R = 3 \Omega \checkmark$
Gradient/ Gradiënt = $\frac{1}{R} = \frac{1}{3} \checkmark$	
$R = 3 \Omega \checkmark$	

(3)

10.2 10.2.1

OPTION 1/ OPSIE 1	OPTION 2/ OPSIE 2
$R_1 = R_2$	$R = \frac{V}{I}$
$I_1 = I_2 = 1 \text{ A} \checkmark$	$R = 6 + 6 = 12 \Omega$
$I = I_1 + I_2 \checkmark$	$12 = \frac{V_p}{1}$
$I = 1 + 1 = 2 \text{ A} \checkmark$	$V_p = 12 \text{ V}$
	$12 = \frac{12}{I}$
	$I = 1 \text{ A} \checkmark$
	$I = I_1 + I_2 \checkmark$
	$I = 1 + 1 = 2 \text{ A} \checkmark$

(3)

10.2.2

$$R = \frac{V}{I} \checkmark$$

$$12 = \frac{V_p}{1} \checkmark$$

$$V_p = 12 \text{ V}$$

$$V = V_s + V_p$$

$$15 = V_s + 12 \checkmark$$

$$V_s = 3 \text{ V}$$

$$R = \frac{V}{I}$$

$$R = \frac{3}{2} \checkmark$$

$$R = 1,5 \Omega \checkmark$$

(5)

10.3 Increase, ✓ the total resistance decreases and the current increases. ✓
Verhoog, die totale weerstand verlaag en die stroom verhoog. (2)

10.4 $W = P\Delta t$ ✓
 $W = 1,5 \times 3,5$ ✓
 $W = 5,25$ kWh
 $\text{Cost} = 5,25 \times 1,15$
 $\text{Cost} = R6,04$ ✓ (3)
[17]

TOTAL/TOTAAL: 150



Province of the
EASTERN CAPE
EDUCATION

**NATIONAL/NASIONALE
SENIOR
CERTIFICATE/SERTIFIKAAT**

GRADE/GRAAD 11

NOVEMBER 2020

**PHYSICAL SCIENCES P1/
FISIESE WETENSKAPPE V1
MARKING GUIDELINE/NASIENRIGLYN
(EXEMPLAR/EKSEMPLAAR)**

MARKS/PUNTE: 150

This marking guideline consists of 10 pages.
Hierdie nasienriglyn bestaan uit 10 bladsye.

QUESTION 1/VRAAG 1

- 1.1 C ✓✓ (2)
- 1.2 B ✓✓ (2)
- 1.3 A ✓✓ (2)
- 1.4 A ✓✓ (2)
- 1.5 D ✓✓ (2)
- 1.6 C ✓✓ (2)
- 1.7 D ✓✓ (2)
- 1.8 B ✓✓ (2)
- 1.9 D ✓✓ (2)
- 1.10 B ✓✓ (2)

[20]**QUESTION 2/VRAAG 2**

- 2.1 The vector sum of two or more vectors. ✓✓
Die som van twee of meer vektore.

OR/OF

A single vector having the same effect as two or more vectors acting together. ✓✓

'n Enkele vektor wat dieselfde effek het as twee of meer vektore wat saam inwerk.

(2)

- 2.2 2.2.1

OPTION 1/ OPSIE 1	OPTION 2/ OPSIE 2
$T_{2X} = T \cos \theta$	$T_{2X} = T \sin \theta$
$T_{2X} = 245 \cos 30^\circ \checkmark$	$T_{2X} = 245 \sin 60^\circ \checkmark$
$T_{2X} = 212,18 \text{ N} \checkmark$	$T_{2X} = 212,18 \text{ N} \checkmark$
$T_{2Y} = T \sin \theta$	$T_{2Y} = T \cos \theta$
$T_{2Y} = 245 \sin 30^\circ \checkmark$	$T_{2Y} = 245 \cos 60^\circ \checkmark$
$T_{2Y} = 122,5 \text{ N} \checkmark$	$T_{2Y} = 122,5 \text{ N} \checkmark$

(4)

- 2.2.2 $T_1 = T_{2X} \checkmark$
 $T_1 = 212,18 \text{ N} \checkmark$

(2)

- 2.2.3 $W = T_{2Y}$
 $W = 122,5 \text{ N}$
 $W = mg$
 $122,5 = m \times 9,8 \checkmark$
 $m = 12,5 \text{ kg} \checkmark$

Any one/Enige een ✓

(3)

[11]

QUESTION 3/VRAAG 3

3.1 The force that opposes the motion of a moving object relative to the surface. ✓✓
 Die krag wat die beweging van 'n bewegende voorwerp relatief tot die oppervlak teenwerk. (2)

3.2 **OPTION 1/OPSIE 1**

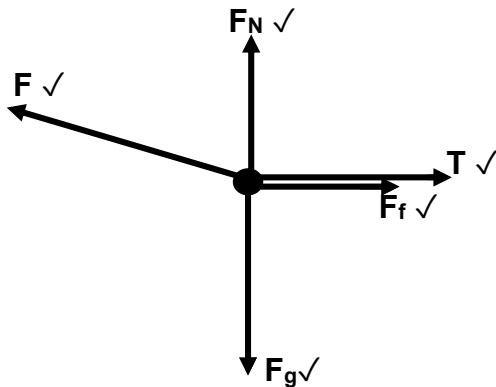

OPTION 2/OPSIE 2

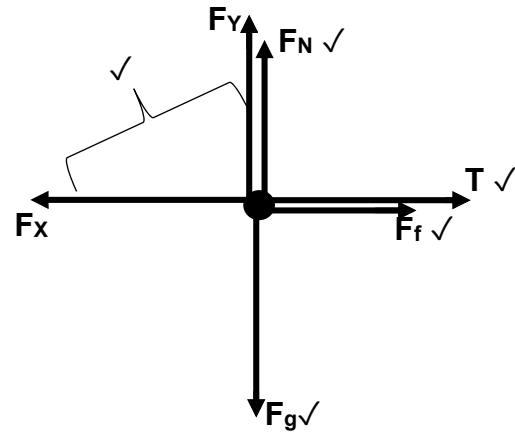

Mark awarded for arrow and label./ Punt toegeken vir byskrif en pyltjie.
 Do not penalise for length of arrows since drawing is not drawn to scale./
 Moenie vir die lengte van die pyltjie penaliseer nie aangesien diagram nie volgens skaal geteken is nie.

Any other additional force(s)./ Enige ander addisionele krag(te). $\frac{4}{5}$

If force(s) do not make contact with body. / As krag(te) nie kontak met die voorwerp maak nie. Max./ Maks. $\frac{4}{5}$ (5)

3.3 3.3.1

OPTION 1/OPSIE 1	OPTION 2/OPSIE 2
$N = F_g - F \sin \theta$ ✓ $N = 25 \times 9,8 - 250 \sin 25^\circ$ ✓ $N = 139,35 \text{ N}$ ✓	$F_Y = F \sin \theta$ $= 250 \sin 25^\circ$ $= 105,66 \text{ N}$ $N = F_g - F_Y$ ✓ $N = 25 \times 9,8 - 105,66$ ✓ $N = 139,34 \text{ N}$ ✓

(3)

3.3.2 POSITIVE MARKING FROM 3.1.1/POSITIEWE NASIEN VANAF 3.1.1

$$\left. \begin{aligned} F_{\text{net}} &= ma \\ F_{\text{net}} &= F \cos \theta - T - f \end{aligned} \right\} \text{Any one/Enige een } \checkmark$$

$$[250 \cos 25^\circ \checkmark - T - (0,15 \times 139,35) \checkmark] \checkmark = 25a$$

$$25a = 205,6744468 - T \dots (1)$$

$$F_{\text{net}} = T - F_g$$

$$T - 98 \checkmark = 10a \dots (2)$$

Adding the two equations/Tel die twee vergelykings bymekaar:

$$35a = 107,6744468$$

$$a = 3,08 \text{ m}\cdot\text{s}^{-2} \checkmark$$

Any one of 25a or 10a/
 Enige een van 25a of 10a ✓

(7)
 [17]

QUESTION 4/VRAAG 4

4.1 When a resultant force acts on an object, the object will accelerate in the direction of the force. The acceleration is directly proportional to the resultant force ✓ and inversely proportional to the mass ✓ of the object.

Wanneer 'n resulterende krag op 'n voorwerp inwerk, sal die voorwerp in die rigting van die krag versnel. Die versnelling is direk eweredig aan die resulterende krag en omgekeerd eweredig aan die massa van die voorwerp. (2)

4.2

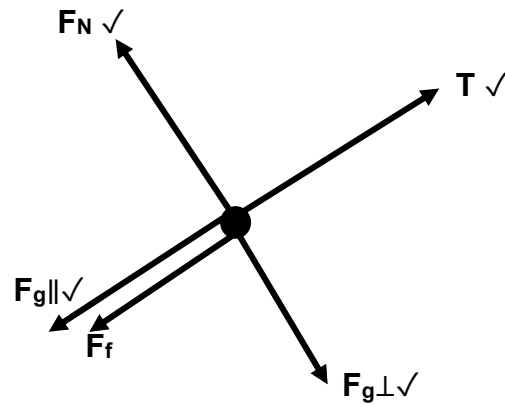
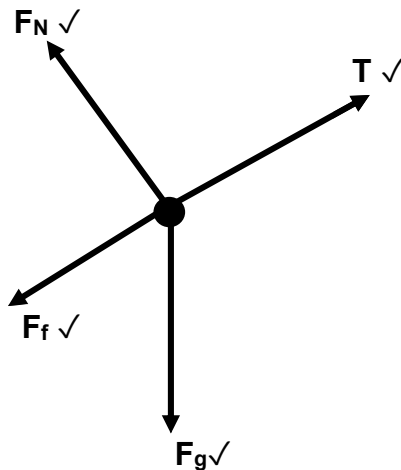

(4)

Mark awarded for arrow and label. / Punt toegeken vir pyltjie en byskrif.

Do not penalise for length of arrows since drawing is not drawn to scale. / Moenie vir die lengte van die pyltjie penaliseer nie aangesien diagram nie volgens skaal geteken is nie.

Any other additional force(s). / Enige ander addisionele krag(te). ^{3/4}

If force(s) do not make contact with body. / As krag(te) nie kontak maak met die voorwerp nie. Max/ Maks ^{3/4}

4.3 4.3.1

$$\left. \begin{aligned} F_{\text{net}} &= ma \\ F_{\text{net}} &= T - F_{g\parallel} - f \\ T - F_{g\parallel} - f &= ma \\ T - F_{g\parallel} - f &= 0 \end{aligned} \right\} \text{Any one/Enige een } \checkmark$$

$$[T - (1,5 \times 9,8 \sin 20^\circ) - 2] = 0 \checkmark$$

$$T = 7,03 \text{ N } \checkmark$$

(5)

4.3.2

$$\left. \begin{aligned} F_{\text{net}} &= ma \\ F_{\text{net}} &= F - T - F_{g\parallel} - f \\ F - T - F_{g\parallel} - f &= ma \\ F - T - F_{g\parallel} - f &= 0 \end{aligned} \right\} \text{Any one/ Enige een } \checkmark$$

$$[24 - 7,03 - (3,2 \times 9,8 \sin 20^\circ) - f_k] = 0 \checkmark$$

$$f_k = 6,22425 \text{ N}$$

$$f_k = \mu_k N \checkmark$$

$$[6,22425 = \mu_k \times 3,2 \times 9,8 \cos 20^\circ] \checkmark$$

$$\mu_k = 0,21 \checkmark$$

(6)

[17]

QUESTION 5/VRAAG 5

- 5.1 Every particle attracts every other particle in the universe with a gravitational force that is directly proportional to the product of their masses and inversely proportional to the square of the distance between their centres. ✓✓

Elke deeltjie lok enige ander deeltjie in die heelal met 'n gravitasiekrag wat direk eweredig is aan die produk van hul massas en omgekeerd eweredig is aan die kwadraat van die afstand tussen hul middelpunte. (2)

5.2 $F = \frac{GM_1M_2}{r^2}$ ✓

$$F = \frac{6,67 \times 10^{-11} \times 5,98 \times 10^{24} \times 1000}{(6,38 \times 10^6 + 2 \times 10^5)^2}$$
 ✓✓

$$F = 9\,212,45 \text{ N}$$
 ✓

(5)

5.3

OPTION 1 / OPSIE 1	OPTION 2 / OPSIE 2
$W = mg$ ✓ $W = 1\,000 \times 9,8$ ✓ $W = 9\,800 \text{ N}$ ✓	$W = \frac{GM_1M_2}{r^2}$ ✓ $W = \frac{6,67 \times 10^{-11} \times 1000 \times 5,98 \times 10^{24}}{(6,38 \times 10^6)^2}$ ✓ $W = 9\,799,09 \text{ N}$ ✓

(3)

5.4 $W = \frac{900}{4}$ ✓ = 2 450 N ✓

When the distance doubles the force will decrease by a factor of 4 ✓.

Wanneer die afstand verdubbel, sal die krag vier (4) keer verminder.

(3)

[13]**QUESTION 6/VRAAG 6**

- 6.1 The ratio of the sine of the angle of incidence in one medium to the sine of the angle of refraction in the other medium is constant. ✓✓

Die verhouding tussen die sinus van die invalshoek in die een medium en die sinus van die brekingshoek in die ander medium is konstant. (2)

6.2 6.2.1 $\frac{n_2}{n_1} = \frac{\sin\theta_1}{\sin\theta_2}$ ✓

$$\frac{1,52}{1} = \frac{\sin 40^\circ}{\sin\theta_2}$$
 ✓

$$\theta_2 = 25,02^\circ$$
 ✓

(4)

6.2.2 $n = \frac{c}{v}$ ✓

$$1,52 = \frac{3 \times 10^8}{v}$$
 ✓

$$v = 1,97 \times 10^8 \text{ m.s}^{-1}$$
 ✓

(3)

$$6.2.3 \quad \frac{n_2}{n_1} = \frac{\sin\theta_1}{\sin\theta_2} \checkmark$$

$$\frac{1,52}{1} = \frac{\sin 90^\circ}{\sin\theta_2} \checkmark$$

$$\theta_2 = 41,14^\circ \checkmark$$

(4)

- 6.3 A phenomenon that occurs when light travels from a denser medium to a less dense medium and the refracted ray does not emerge from the medium, but is reflected back into the medium. $\checkmark\checkmark$

'n Verskynsel wat voorkom wanneer lig van 'n digter medium na 'n minder digte medium beweeg en die gebreekte straal nie uit die medium kom nie, maar weer terug in die medium weerkaats.

(2)

- 6.4 The light must travel from a denser medium to a less dense medium. \checkmark
The angle of incidence must be greater than the critical angle of the denser medium. \checkmark

*Die lig moet van 'n digter medium na 'n minder digte medium beweeg.
Die invalshoek moet groter wees as die grenshoek van die digter medium.*

(2)

[17]**QUESTION 7/VRAAG 7**

- 7.1 Diffraction/ *Diffraksie* \checkmark

(1)

7.2

 $\checkmark\checkmark$ $\checkmark\checkmark$

(4)

- 7.3 The coloured bands for red light are broader than those of blue light. \checkmark
The wavelength for red light is longer than that of a blue light. \checkmark
*Die gekleurde bande vir rooi lig is breër as dié van blou lig.
Die golflengte vir rooi lig is langer as dié van blou lig.*

(2)

- 7.4 Light has a wave nature / *Lig het golf-aard* \checkmark

(1)

7.5 The coloured bands will become broader./ Die gekleurde bande sal breër word. ✓

The slit width is inversely proportional to the degree of diffraction. ✓✓
Die spleetwydte is omgekeerd eweredig aan die mate van diffraksie.

OR/OF

Smaller width gives broader diffraction./ Kleiner breedte gee breër diffraksie. ✓✓ (3)

[11]

QUESTION 8/VRAAG 8

8.1

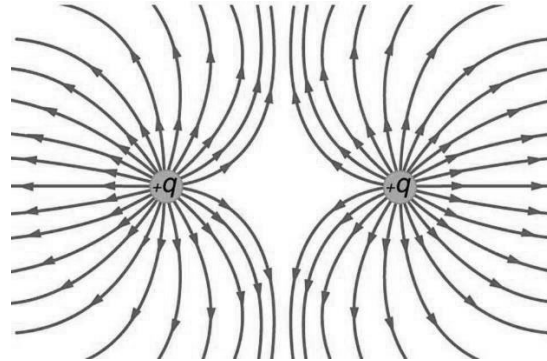

CRITERIA FOR MARKING/ KRITERIA VIR NASIEN	
Correct shape/ Korrekte vorm.	✓
Direction of field lines./ Rigting van veldlyne	✓
Field lines not crossing each other./ Veldlyne kruis nie mekaar nie.	✓

(3)

8.2 $F = \frac{kQ_1Q_2}{r^2}$ ✓

$$5,09 \text{ ✓} = \frac{9 \times 10^9 \times Q^2}{0,1^2} \text{ ✓}$$

$$Q = 2,38 \times 10^{-6} \text{ C ✓}$$

(4)

8.3 $E = \frac{kQ}{r^2}$ ✓

$$E_1 = \frac{9 \times 10^9 \times 2,38 \times 10^{-6}}{0,15^2} \text{ ✓}$$

$$E_1 = 952\,000 \text{ NC}^{-1} \text{ right / regs}$$

$$E_2 = \frac{9 \times 10^9 \times 2,38 \times 10^{-6}}{0,05^2} \text{ ✓}$$

$$E_2 = 8\,568\,000 \text{ NC}^{-1} \text{ right / regs}$$

$$E_{\text{net}} = E_1 + E_2$$

$$E_{\text{net}} = 952\,000 + 8\,568\,000 \text{ ✓}$$

$$E_{\text{net}} = 9\,520\,000 \text{ NC}^{-1} \text{ right / regs ✓}$$

(5)

$$8.4 \quad F = \frac{kQ_1Q_2}{r^2} \quad \checkmark$$

$$F_1 = \frac{9 \times 10^9 \times 2,38 \times 10^{-6} \times 2,38 \times 10^{-6}}{0,1^2} \quad \checkmark$$

$$F_1 = 5,10 \text{ N right}$$

$$F_2 = \frac{9 \times 10^9 \times 2,38 \times 10^{-6} \times 2,38 \times 10^{-6}}{0,05^2} \quad \checkmark$$

$$F_2 = 42,84 \text{ N left / links}$$

$$F_{\text{net}} = F_1 + F_2$$

$$F_{\text{net}} = 42,84 - 5,10 \quad \checkmark$$

$$F_{\text{net}} = 37,74 \text{ N left / links} \quad \checkmark$$

(5)
[17]**QUESTION 9/VRAAG 9**

9.1

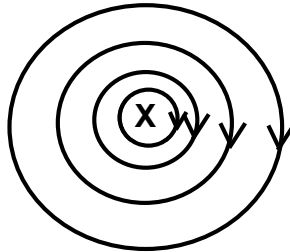
**CRITERIA FOR MARKING/ KRITERIA VIR NASIEN**

Circular shape/ Korrekte vorm	✓
Field direction/ Veldrigting	✓

(2)

9.2 9.2.1 The magnitude of the induced emf across a conductor is directly proportional to the rate of change in the magnetic flux linkage with the conductor. ✓✓

Die grootte van die geïnduseerde emk oor die geleier is direk eweredig aan die tempo van verandering in die magnetiese vloed met die geleier.

(2)

$$9.2.2 \quad \left. \begin{array}{l} \Phi = B A \cos \theta \\ \Phi = B (\pi r^2) \cos \theta \end{array} \right\} \text{Any one/Enige een } \checkmark$$

$$\Phi = 3,5 (\pi \times 0,05^2) \cos 0^\circ \quad \checkmark$$

$$\Phi = 0,03 \text{ Wb } \checkmark \quad (0,027 \text{ Wb})$$

(3)

$$9.2.3 \quad \varepsilon = \frac{-N\Delta\Phi}{\Delta t} \quad \checkmark$$

$$\varepsilon = \frac{-350(0 - 0,03)}{0,1} \quad \checkmark$$

$$\varepsilon = 105 \text{ V } \checkmark$$

(3)
[10]

QUESTION 10/VRAAG 10

10.1 10.1.1 The inverse of the resistance / Die omgekeerde van die weerstand

$$\text{OR/ OF } \frac{1}{R} \checkmark$$

(1)

10.1.2

OPTION 1/ OPSIE 1	OPTION 2/ OPSIE 2
Gradient/ Gradiënt = $\frac{\Delta I}{\Delta V}$	$R = \frac{V}{I} \checkmark$
Gradient/ Gradiënt = $\frac{1,0-0,2}{3,0-0,6} \checkmark$	$R = \frac{3,0}{1,0} \checkmark$
Gradient/ Gradiënt = $\frac{1}{3}$	$R = 3 \Omega \checkmark$
Gradient/ Gradiënt = $\frac{1}{R} = \frac{1}{3} \checkmark$	
$R = 3 \Omega \checkmark$	

(3)

10.2 10.2.1

OPTION 1/ OPSIE 1	OPTION 2/ OPSIE 2
$R_1 = R_2$	$R = \frac{V}{I}$
$I_1 = I_2 = 1 \text{ A} \checkmark$	$R = 6 + 6 = 12 \Omega$
$I = I_1 + I_2 \checkmark$	$12 = \frac{V_p}{1}$
$I = 1 + 1 = 2 \text{ A} \checkmark$	$V_p = 12 \text{ V}$
	$12 = \frac{12}{I}$
	$I = 1 \text{ A} \checkmark$
	$I = I_1 + I_2 \checkmark$
	$I = 1 + 1 = 2 \text{ A} \checkmark$

(3)

10.2.2

$$R = \frac{V}{I} \checkmark$$

$$12 = \frac{V_p}{1} \checkmark$$

$$V_p = 12 \text{ V}$$

$$V = V_s + V_p$$

$$15 = V_s + 12 \checkmark$$

$$V_s = 3 \text{ V}$$

$$R = \frac{V}{I}$$

$$R = \frac{3}{2} \checkmark$$

$$R = 1,5 \Omega \checkmark$$

(5)

10.3 Increase, ✓ the total resistance decreases and the current increases. ✓
Verhoog, die totale weerstand verlaag en die stroom verhoog. (2)

10.4 $W = P\Delta t$ ✓
 $W = 1,5 \times 3,5$ ✓
 $W = 5,25$ kWh
 $\text{Cost} = 5,25 \times 1,15$
 $\text{Cost} = R6,04$ ✓ (3)
[17]

TOTAL/TOTAAL: 150