



# basic education

Department:  
Basic Education  
**REPUBLIC OF SOUTH AFRICA**

**NATIONAL  
SENIOR CERTIFICATE**

**GRADE 12**

**PHYSICAL SCIENCES: PHYSICS (P1)**

**NOVEMBER 2019**

**MARKS: 150**

**TIME: 3 hours**

**This question paper consists of 17 pages and 3 data sheets.**

**INSTRUCTIONS AND INFORMATION**

1. Write your examination number and centre number in the appropriate spaces on the ANSWER BOOK.
2. This question paper consists of TEN questions. Answer ALL the questions in the ANSWER BOOK.
3. Start EACH question on a NEW page in the ANSWER BOOK.
4. Number the answers correctly according to the numbering system used in this question paper.
5. Leave ONE line between two subquestions, e.g. between QUESTION 2.1 and QUESTION 2.2.
6. You may use a non-programmable calculator.
7. You may use appropriate mathematical instruments.
8. Show ALL formulae and substitutions in ALL calculations.
9. Round off your FINAL numerical answers to a minimum of TWO decimal places.
10. Give brief motivations, discussions, etc. where required.
11. You are advised to use the attached DATA SHEETS.
12. Write neatly and legibly.

**QUESTION 1: MULTIPLE-CHOICE QUESTIONS**

Various options are provided as possible answers to the following questions. Choose the answer and write only the letter (A–D) next to the question numbers (1.1 to 1.10) in the ANSWER BOOK, e.g. 1.11 E. Each question has only ONE correct answer.

- 1.1 Which physical quantity is equal to the rate of change of momentum?
- A Mass
  - B Impulse
  - C Net force
  - D Acceleration (2)
- 1.2 The gravitational acceleration on the surface of a planet of radius  $R$  is  $g$ .  
The gravitational acceleration at a height of  $2R$  above the surface of the same planet is ...
- A  $\frac{g}{9}$
  - B  $\frac{g}{4}$
  - C  $4g$
  - D  $9g$  (2)
- 1.3 A ball falls from the edge of a table. Ignore the effects of air friction.  
Which ONE of the physical quantities associated with the ball during the fall remains constant?
- A Weight
  - B Momentum
  - C Kinetic energy
  - D Gravitational potential energy (2)

- 1.4 Two trolleys, **X** and **Y**, of masses  $m$  and  $2m$  respectively, are held together by a compressed spring between them. Initially they are stationary on a horizontal floor, as shown below. Ignore the effects of friction.

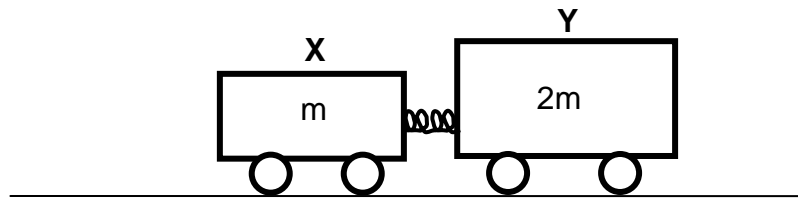

The spring is now released and falls to the floor while the trolleys move apart.

The magnitude of the MOMENTUM of trolley **X** while it moves away is ...

- A zero.
- B half the magnitude of the momentum of trolley **Y**.
- C twice the magnitude of the momentum of trolley **Y**.
- D the same as the magnitude of the momentum of trolley **Y**. (2)
- 1.5 An object is dropped from rest and after falling a distance  $x$ , its momentum is  $p$ . Ignore the effects of air friction.

The momentum of the object, after it has fallen a distance  $2x$ , is ...

- A  $p$
- B  $\sqrt{2}p$
- C  $\frac{p}{2}$
- D  $2p$  (2)
- 1.6 A police car, with its siren on, is travelling at a constant speed TOWARDS a stationary sound detector. The siren emits sound waves of frequency  $f$  and speed  $v$ .

Which ONE of the following combinations best describes the frequency and speed of the detected sound waves?

	FREQUENCY	SPEED
A	Less than $f$	$v$
B	Less than $f$	Less than $v$
C	Greater than $f$	Less than $v$
D	Greater than $f$	$v$

(2)

- 1.7 Two identical spheres, **R** and **S**, on insulated stands, carrying charges of  $+q$  and  $-q$  respectively, are placed a distance apart. Sphere **R** exerts an electrostatic force of magnitude  $F$  on sphere **S**.

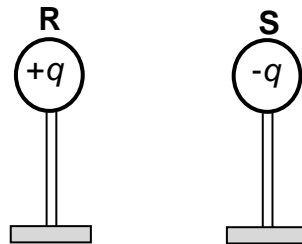

The two spheres are now brought into contact and returned to their original positions.

The magnitude of the electrostatic force that sphere **R** exerts on sphere **S** is now ...

A zero

B  $\frac{F}{2}$

C  $F$

D  $2F$

(2)

- 1.8 Which ONE of the graphs below best represents the relationship between potential difference ( $V$ ) and current ( $I$ ) for an ohmic conductor?

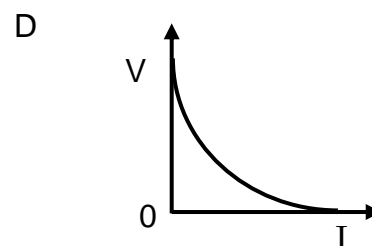
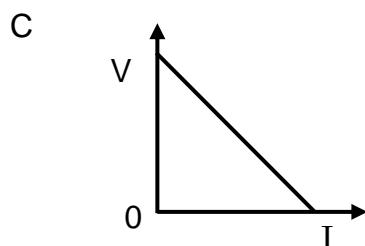
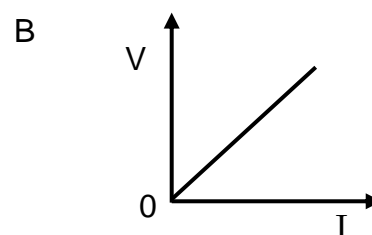
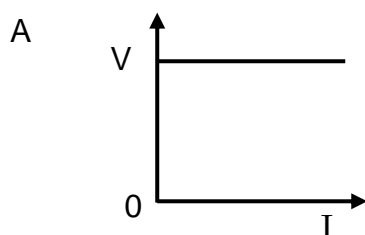

(2)

- 1.9 Which ONE of the following combinations regarding the energy conversions in electric motors and electric generators is CORRECT?

	<b>ENERGY CONVERSION IN MOTORS</b>	<b>ENERGY CONVERSION IN GENERATORS</b>
A	Mechanical to electrical	Electrical to mechanical
B	Mechanical to electrical	Mechanical to electrical
C	Electrical to mechanical	Electrical to mechanical
D	Electrical to mechanical	Mechanical to electrical

(2)

- 1.10 Consider the statements below regarding the photoelectric effect.

The photoelectric effect proves that ...

- (i) light energy is quantised.
- (ii) light has a particle nature.
- (iii) light has a wave nature.

Which of the statements above is/are CORRECT?

- A (i) only
- B (ii) only
- C (i) and (ii) only
- D (i) and (iii) only

(2)  
[20]

**QUESTION 2 (Start on a new page.)**

Block **P**, of mass 2 kg, is connected to block **Q**, of mass 3 kg, by a light inextensible string. Both blocks are on a plane inclined at an angle of  $30^\circ$  to the horizontal.

Block **Q** is pulled by a constant force of 40 N at an angle of  $25^\circ$  to the incline.

Block **P** moves on a rough section, **AB**, of the incline, while block **Q** moves on a frictionless section, **BC**, of the incline. See diagram below.

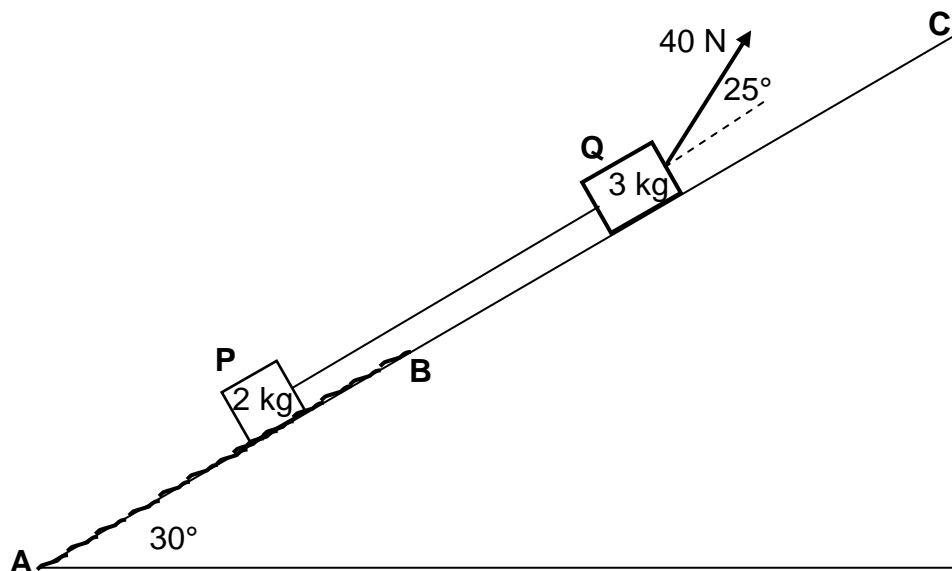

An average constant frictional force of 2,5 N acts on block **P** as it moves from **A** to **B** up the incline.

- 2.1 State Newton's Second Law in words. (2)
- 2.2 Draw a labelled free-body diagram for block **P**. (4)
- 2.3 Calculate the magnitude of the acceleration of block **P** while block **P** is moving on section **AB**. (8)
- 2.4 If block **P** has now passed point **B**, how will its acceleration compare to that calculated in QUESTION 2.3? Choose from GREATER THAN, SMALLER THAN or EQUAL TO. (2)

Give a reason for the answer.

(2)  
**[16]**

**QUESTION 3 (Start on a new page.)**

Stone **A** is thrown vertically upwards with a speed of  $10 \text{ m}\cdot\text{s}^{-1}$  from the edge of the roof of a 40 m high building, as shown in the diagram below.

Ignore the effects of air friction. Take the ground as reference.

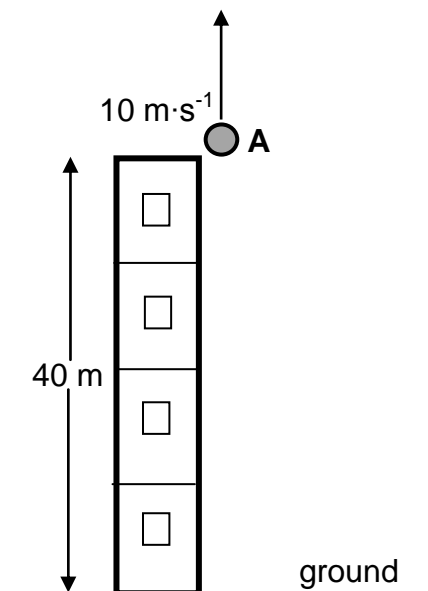

- 3.1 Define the term *free fall*. (2)
- 3.2 Calculate the maximum HEIGHT ABOVE THE GROUND reached by stone **A**. (4)
- 3.3 Write down the magnitude and direction of the acceleration of stone **A** at this maximum height. (2)

Stone **B** is dropped from rest from the edge of the roof,  $x$  seconds after stone **A** was thrown upwards.

- 3.4 Stone **A** passes stone **B** when the two stones are 29,74 m above the ground.  
Calculate the value of  $x$ . (6)



- 3.5 The graphs of position versus time for part of the motion of both stones are shown below.

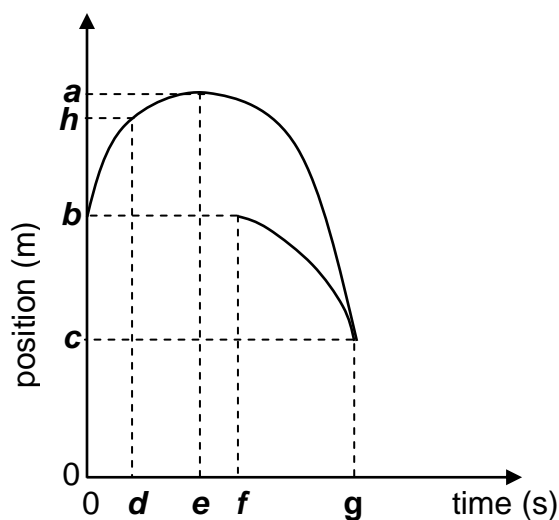

Which of labels **a** to **h** on the graphs above represents EACH of the following?

- 3.5.1 The time at which stone **A** has a positive velocity (1)
- 3.5.2 The maximum height reached by stone **A** (1)
- 3.5.3 The time when stone **B** was dropped (1)
- 3.5.4 The height at which the stones pass each other (1)
- [18]**

**QUESTION 4 (Start on a new page.)**

A bullet moves east at a velocity of  $480 \text{ m}\cdot\text{s}^{-1}$ . It hits a wooden block that is fixed to the floor. The bullet takes  $0,01 \text{ s}$  to move through the stationary block and emerges from the block at a velocity of  $80 \text{ m}\cdot\text{s}^{-1}$  east. See the diagram below.

Ignore the effects of air resistance.

Consider the block-bullet system as an isolated system.

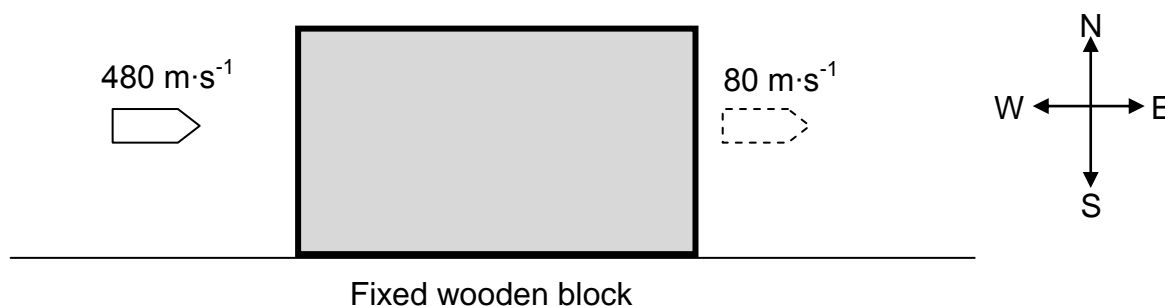

4.1 Explain what is meant by an *isolated system* as used in Physics. (2)

The magnitude of the momentum of the bullet before it enters the block is  $24 \text{ kg}\cdot\text{m}\cdot\text{s}^{-1}$ .

4.2 Calculate the:

4.2.1 Mass of the bullet (3)

4.2.2 Average net force exerted by the wooden block on the bullet (5)

**[10]**

**QUESTION 5 (Start on a new page.)**

An object of mass  $1,8 \text{ kg}$  slides down a rough curved track and passes point **A**, which is  $1,5 \text{ m}$  above the ground, at a speed of  $0,95 \text{ m}\cdot\text{s}^{-1}$ .

The object reaches point **B** at the bottom of the track at a speed of  $4 \text{ m}\cdot\text{s}^{-1}$ .

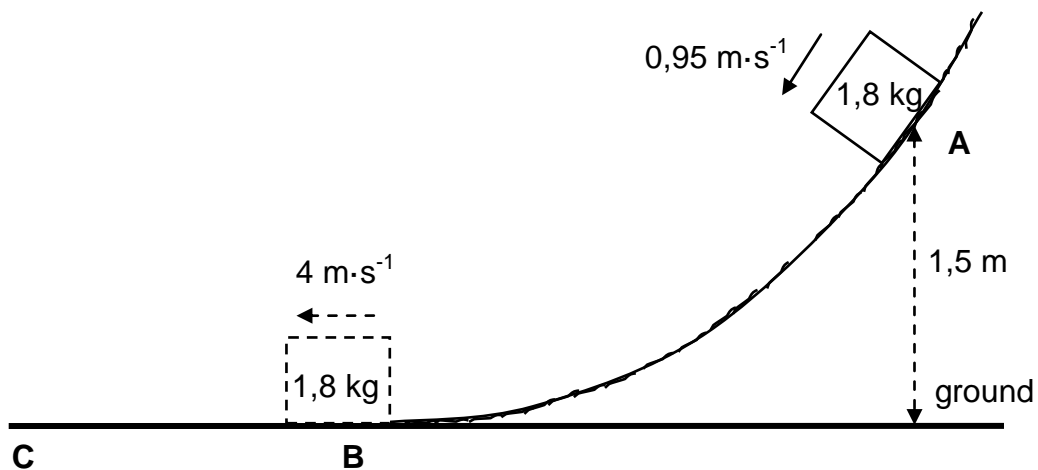

- 5.1 Define the term *conservative force*. (2)
- 5.2 Name the conservative force acting on the object. (1)
- 5.3 Is mechanical energy conserved as the object slides from point **A** to point **B**? Choose from YES or NO. Give a reason for the answer. (2)
- 5.4 Calculate the gravitational potential energy of the object when it was at point **A**. (3)
- 5.5 Using energy principles, calculate the work done by friction on the object as it slides from point **A** to point **B**. (4)
- Surface **BC** in the diagram above is frictionless.
- 5.6 What is the value of the net work done on the object as it slides from point **B** to point **C**? (1)

**[13]**

**QUESTION 6 (Start on a new page.)**

The siren of a police car, which is travelling at a constant speed along a straight horizontal road, emits sound waves of constant frequency. Detector **P** is placed inside the police car and detector **Q** is placed next to the road at a certain distance away from the car. The two detectors record the changes in the air pressure readings caused by the sound waves emitted by the siren as a function of time.

The graphs below were obtained from the recorded results.

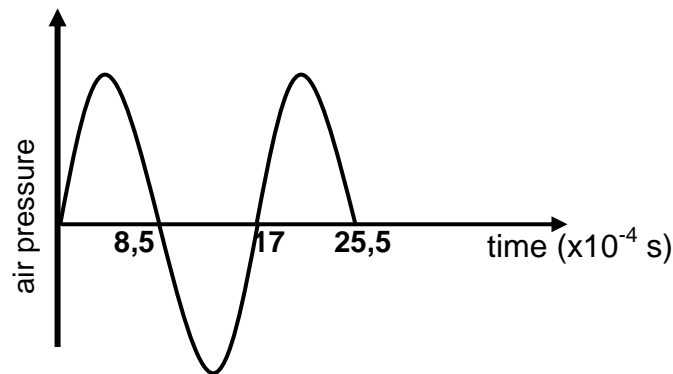
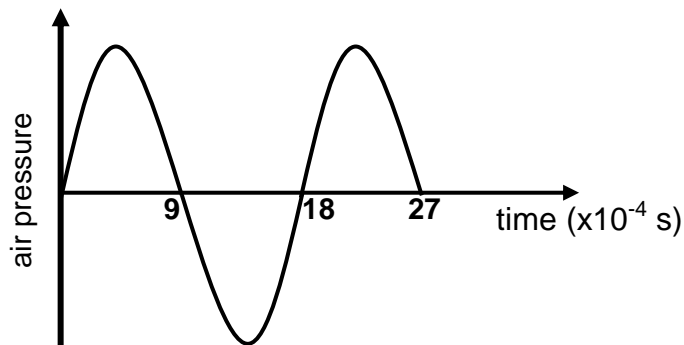
**GRAPH A: AIR PRESSURE VS TIME RECORDED BY DETECTOR P IN THE CAR****GRAPH B: AIR PRESSURE VS TIME RECORDED BY DETECTOR Q NEXT TO THE ROAD**

- 6.1 Different patterns are shown above for the same sound wave emitted by the siren. What phenomenon is illustrated by the two detectors showing the different patterns? (1)

The police car is moving AWAY from detector **Q**.

- 6.2 Use the graphs and give a reason why it can be confirmed that the police car is moving away from detector **Q**. (1)
- 6.3 Calculate the frequency of the sound waves recorded by detector **P**. (3)
- 6.4 Use the information in the graphs to calculate the speed of the police car. Take the speed of sound in air as  $340 \text{ m}\cdot\text{s}^{-1}$ . (6)

**[11]**

**QUESTION 7 (Start on a new page.)**

- 7.1 A small sphere, **Y**, carrying an unknown charge, is suspended at the end of a light inextensible string which is attached to a fixed point. Another sphere, **X**, carrying a charge of  $+6 \times 10^{-6} \text{ C}$ , on an insulated stand is brought close to sphere **Y**.

Sphere **Y** experiences an electrostatic force and comes to rest 0,2 m away from sphere **X**, with the string at an angle of  $10^\circ$  with the vertical, as shown in the diagram below.

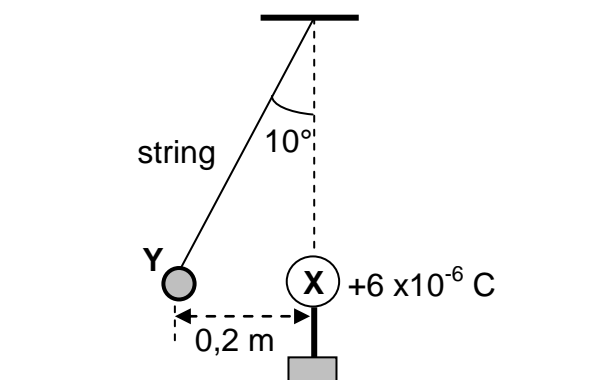

- 7.1.1 What is the nature of the charge on sphere **Y**? Choose from POSITIVE or NEGATIVE. (1)
- 7.1.2 Calculate the magnitude of the charge on sphere **Y** if the magnitude of the electrostatic force acting on it is 3,05 N. (3)
- 7.1.3 Draw a labelled free-body diagram for sphere **Y**. (3)
- 7.1.4 Calculate the magnitude of the tension in the string. (3)
- 7.2 Two small charged spheres, **A** and **B**, on insulated stands, with charges  $+2 \times 10^{-5} \text{ C}$  and  $-4 \times 10^{-5} \text{ C}$  respectively, are placed 0,4 m apart, as shown in the diagram below. **M** is the midpoint between spheres **A** and **B**.

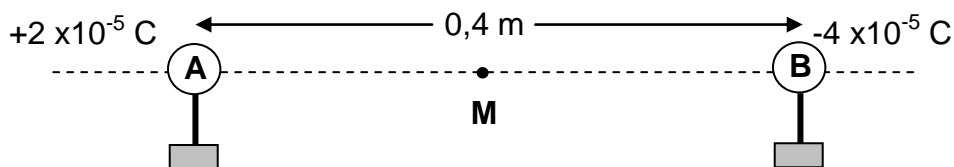

- 7.2.1 Define the term *electric field at a point*. (2)
- 7.2.2 Calculate the net electric field at point **M**. (6)
- [18]**

**QUESTION 8 (Start on a new page.)**

In the circuit diagram below, resistor **R**, with a resistance of  $5,6 \Omega$ , is connected, together with a switch, an ammeter and a high-resistance voltmeter, to a battery with an unknown internal resistance,  $r$ .

The resistance of the connecting wires and the ammeter may be ignored.

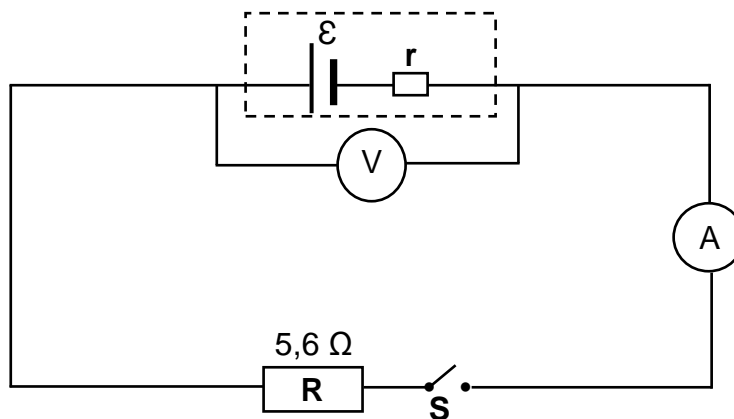

The graph below shows the potential difference across the terminals of the battery as a function of time.

At time  $t_1$ , switch **S** is closed.

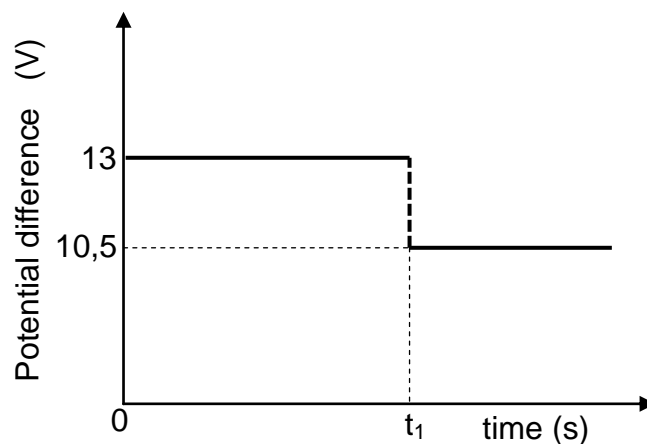

- 8.1 Define the term *emf* of a battery. (2)
- 8.2 Write down the value of the emf of the battery. (1)
- 8.3 When switch **S** is CLOSED, calculate the:
- 8.3.1 Current through resistor **R** (3)
- 8.3.2 Power dissipated in resistor **R** (3)
- 8.3.3 Internal resistance,  $r$ , of the battery (3)

- 8.4 Two IDENTICAL resistors, each with resistance  $X$ , are now connected in the same circuit with switch  $S$  closed, as shown below.

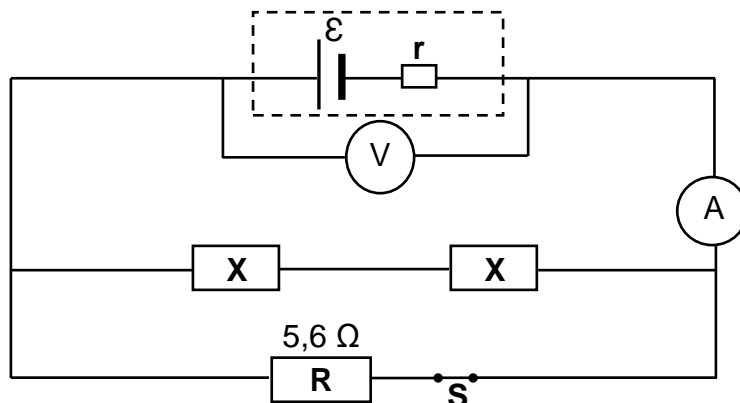

The ammeter reading now increases to 4 A.

- 8.4.1 How would the voltmeter reading change? Choose from INCREASES, DECREASES or REMAINS THE SAME.

Give a reason for the answer by referring to  $V_{\text{internal resistance}}$ . (2)

- 8.4.2 Calculate resistance  $X$ .

(5)  
[19]

**QUESTION 9 (Start on a new page.)**

- 9.1 A simplified diagram of an electric generator is shown below. When the coil is rotated with a constant speed, an emf is induced in the coil.

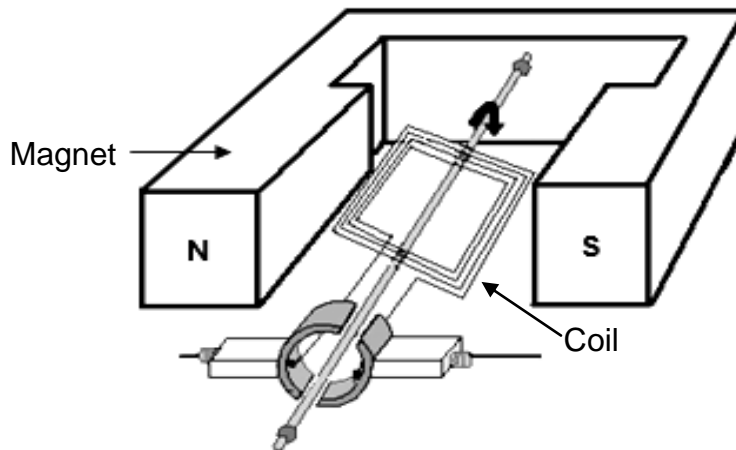

- 9.1.1 Is this an AC generator or a DC generator? (1)
- 9.1.2 Briefly explain how an emf is generated in the coil when the coil is rotated by referring to the principle of electromagnetic induction. (2)
- 9.1.3 Draw a sketch graph of the output voltage versus time for this generator. Show ONE complete cycle. (2)
- 9.2 A  $200\ \Omega$  resistor is connected to a DC voltage supply, as shown in diagram **A**. The energy dissipated in the resistor in 10 s is 500 J.

The same resistor is now connected to an AC source (diagram **B**) and 500 J of energy is also dissipated in the resistor in 10 s.

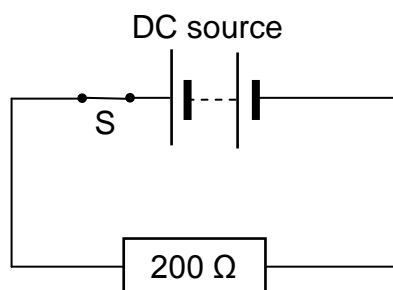
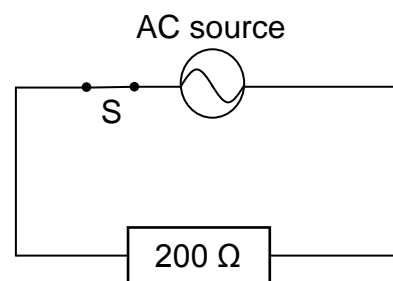
Diagram **A**Diagram **B**

- 9.2.1 Define the term *rms voltage* of an AC source. (2)
- 9.2.2 Calculate the maximum (peak) voltage of the AC source. (5)

**[12]**



**QUESTION 10 (Start on a new page.)**

During an experiment, light of different frequencies is radiated onto a silver cathode of a photocell and the corresponding maximum speed of the ejected photoelectrons are measured.

A graph of the energy of the incident photons versus the square of the maximum speed of the ejected photoelectrons is shown below.

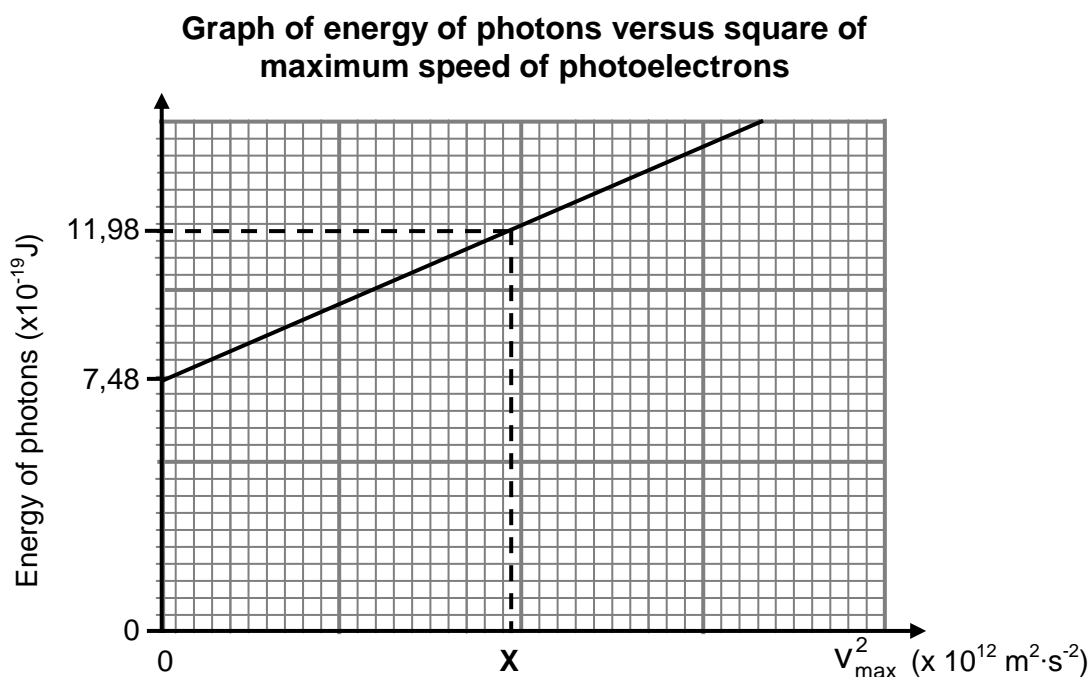

10.1 Define the term *photoelectric effect*. (2)

Use the graph to answer the following questions.

10.2 Write down the value of the work function of silver.  
Use a relevant equation to justify the answer. (3)

10.3 Which physical quantity can be determined from the gradient of the graph? (1)

10.4 Calculate the value of X as shown on the graph. (5)

The experiment above is now repeated using light of higher intensity.

10.5 How will EACH of the following be affected? Choose from INCREASES, DECREASES or REMAINS THE SAME.

10.5.1 The gradient of the graph (1)

10.5.2 The number of photoelectrons emitted per unit time (1)

**[13]**

**TOTAL: 150**

**DATA FOR PHYSICAL SCIENCES GRADE 12  
PAPER 1 (PHYSICS)**

**GEGEWENS VIR FISIESTE WETENSAPPE GRAAD 12  
VRAESTEL 1 (FISIKA)**

**TABLE 1: PHYSICAL CONSTANTS/TABEL 1: FISIESTE KONSTANTES**

NAME/NAAM	SYMBOL/SIMBOOL	VALUE/WAARDE
Acceleration due to gravity <i>Swaartekragversnelling</i>	g	9,8 m·s <sup>-2</sup>
Universal gravitational constant <i>Universele gravitasiekonstant</i>	G	6,67 x 10 <sup>-11</sup> N·m <sup>2</sup> ·kg <sup>-2</sup>
Radius of the Earth <i>Radius van die Aarde</i>	R <sub>E</sub>	6,38 x 10 <sup>6</sup> m
Mass of the Earth <i>Massa van die Aarde</i>	M <sub>E</sub>	5,98 x 10 <sup>24</sup> kg
Speed of light in a vacuum <i>Spoed van lig in 'n vakuum</i>	c	3,0 x 10 <sup>8</sup> m·s <sup>-1</sup>
Planck's constant <i>Planck se konstante</i>	h	6,63 x 10 <sup>-34</sup> J·s
Coulomb's constant <i>Coulomb se konstante</i>	k	9,0 x 10 <sup>9</sup> N·m <sup>2</sup> ·C <sup>-2</sup>
Charge on electron <i>Lading op elektron</i>	e	-1,6 x 10 <sup>-19</sup> C
Electron mass <i>Elektronmassa</i>	m <sub>e</sub>	9,11 x 10 <sup>-31</sup> kg

**TABLE 2: FORMULAE/TABEL 2: FORMULES****MOTION/BEWEGING**

$v_f = v_i + a \Delta t$	$\Delta x = v_i \Delta t + \frac{1}{2} a \Delta t^2$ or/of $\Delta y = v_i \Delta t + \frac{1}{2} a \Delta t^2$
$v_f^2 = v_i^2 + 2a\Delta x$ or/of $v_f^2 = v_i^2 + 2a\Delta y$	$\Delta x = \left( \frac{v_i + v_f}{2} \right) \Delta t$ or/of $\Delta y = \left( \frac{v_i + v_f}{2} \right) \Delta t$

**FORCE/KRAG**

$F_{\text{net}} = ma$	$p = mv$
$f_s^{\text{max}} = \mu_s N$	$f_k = \mu_k N$
$F_{\text{net}} \Delta t = \Delta p$ $\Delta p = mv_f - mv_i$	$w = mg$
$F = G \frac{m_1 m_2}{d^2}$ or/of $F = G \frac{m_1 m_2}{r^2}$	$g = G \frac{M}{d^2}$ or/of $g = G \frac{M}{r^2}$

**WORK, ENERGY AND POWER/ARBEID, ENERGIE EN DRYWING**

$W = F \Delta x \cos \theta$	$U = mgh$ or/of $E_p = mgh$
$K = \frac{1}{2} mv^2$ or/of $E_k = \frac{1}{2} mv^2$	$W_{\text{net}} = \Delta K$ or/of $W_{\text{net}} = \Delta E_k$ $\Delta K = K_f - K_i$ or/of $\Delta E_k = E_{kf} - E_{ki}$
$W_{\text{nc}} = \Delta K + \Delta U$ or/of $W_{\text{nc}} = \Delta E_k + \Delta E_p$	$P = \frac{W}{\Delta t}$
$P_{\text{ave}} = FV_{\text{ave}}$ / $P_{\text{gemid}} = FV_{\text{gemid}}$	

**WAVES, SOUND AND LIGHT/GOLWE, KLANK EN LIG**

$v = f \lambda$	$T = \frac{1}{f}$
$f_L = \frac{v \pm v_L}{v \pm v_s} f_s$ or/of $f_L = \frac{v \pm v_L}{v \pm v_b} f_b$	$E = hf$ or /of $E = \frac{hc}{\lambda}$
$E = W_0 + E_{k(\text{max})}$ or/of $E = W_0 + K_{\text{max}}$ where/waar	
$E = hf$ and/en $W_0 = hf_0$ and/en $E_{k(\text{max})} = \frac{1}{2} mv_{\text{max}}^2$ or/of $K_{\text{max}} = \frac{1}{2} mv_{\text{max}}^2$	

**ELECTROSTATICS/ELEKTROSTATIKA**

$F = \frac{kQ_1Q_2}{r^2}$	$E = \frac{kQ}{r^2}$
$V = \frac{W}{q}$	$E = \frac{F}{q}$
$n = \frac{Q}{e}$ or / of $n = \frac{Q}{q_e}$	

**ELECTRIC CIRCUITS/ELEKTRIESE STROOMBANE**

$R = \frac{V}{I}$	emf ( $\epsilon$ ) = I(R + r) emk ( $\epsilon$ ) = I(R + r)
$R_s = R_1 + R_2 + \dots$ $\frac{1}{R_p} = \frac{1}{R_1} + \frac{1}{R_2} + \dots$	$q = I\Delta t$
$W = Vq$ $W = VI\Delta t$ $W = I^2R\Delta t$ $W = \frac{V^2\Delta t}{R}$	$P = \frac{W}{\Delta t}$ $P = VI$ $P = I^2R$ $P = \frac{V^2}{R}$

**ALTERNATING CURRENT/WISSELSTROOM**

$I_{rms} = \frac{I_{max}}{\sqrt{2}}$ / $I_{wgk} = \frac{I_{maks}}{\sqrt{2}}$	$P_{ave} = V_{rms}I_{rms}$ / $P_{gemiddeld} = V_{wgk}I_{wgk}$
$V_{rms} = \frac{V_{max}}{\sqrt{2}}$ / $V_{wgk} = \frac{V_{maks}}{\sqrt{2}}$	$P_{ave} = I_{rms}^2R$ / $P_{gemiddeld} = I_{wgk}^2R$
	$P_{ave} = \frac{V_{rms}^2}{R}$ / $P_{gemiddeld} = \frac{V_{wgk}^2}{R}$



# basic education

Department:  
Basic Education  
**REPUBLIC OF SOUTH AFRICA**

**NATIONAL  
SENIOR CERTIFICATE  
NASIONALE  
SENIOR SERTIFIKAAT**

**GRADE/GRAAD 12**

**PHYSICAL SCIENCES: PHYSICS (P1)  
FISIESE WETENSKAPPE: FISIKA (V1)**

**NOVEMBER 2019**

**MARKING GUIDELINES/NASIENRIGLYNE**

**MARKS/PUNTE: 150**

**These marking guidelines consist of 24 pages. /  
Hierdie nasienriglyne bestaan uit 24 bladsye.**

**QUESTION 1/VRAAG 1**

- 1.1 C ✓✓ (2)
- 1.2 A ✓✓ (2)
- 1.3 A ✓✓ (2)
- 1.4 D ✓✓ (2)
- 1.5 B ✓✓ (2)
- 1.6 D ✓✓ (2)
- 1.7 A ✓✓ (2)
- 1.8 B ✓✓ (2)
- 1.9 D ✓✓ (2)
- 1.10 C ✓✓ (2)
- [20]**

**QUESTION 2/VRAAG 2**

**NOTE:** -1 mark for each key word/phrase omitted in the correct context  
**LET WEL:** -1 punt vir elke sleutel woord/frase in die korrekte konteks weggelaat

2.1 When a resultant/net force acts on an object, the object will accelerate in the direction of the force with an acceleration that is directly proportional to the force and inversely proportional to the mass of the object. ✓ ✓  
*Wanneer 'n resultante/netto krag op 'n voorwerp inwerk, sal die voorwerp in die rigting van die krag versnel teen 'n versnelling wat direk eweredig is aan die krag en omgekeerd eweredig aan die massa van die voorwerp.*

(2)

**OR/OF**

The resultant/net force acting on an object is equal to the rate of change of momentum of the object (in the direction of the resultant/net force.) ✓ ✓  
*Die netto krag wat op 'n voorwerp inwerk is gelyk aan die tempo van verandering van momentum van die voorwerp (in die rigting van die resulterende/netto krag.)*

(2)

2.2

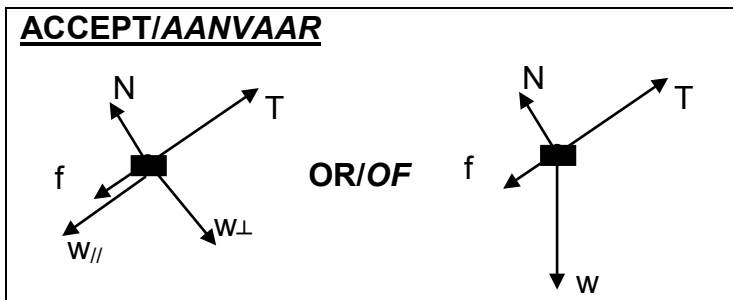
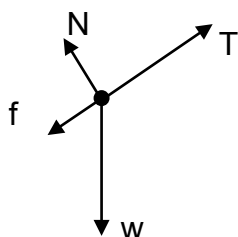

	<b>Accept the following symbols/Aanvaar die volgende simbole.</b>
N ✓	$F_N$ /Normal/ <i>Normaal</i> /Normal force/ <i>Normaalkrag</i> /16,97 N
f ✓	$F_f$ / $f_k$ / $f_r$ / frictional force/ <i>wrywingskrag</i> /kinetic frictional force/ <i>kinetiese wrywingskrag</i>
W ✓	$F_g$ ,/mg/weight/ $F_{\text{Earth on block}}$ /19,6 N/ <i>gravitational force</i> / <i>gewig</i> / $F_{\text{aarde op blok}}$ / <i>gravitasiekrag</i>
T ✓	Tension/ <i>Spanning</i> / $F_T$ / $F_A$ / F / $F_s$

**Notes/Aantekeninge**

- Mark is awarded for label and arrow. /Punt word toegeken vir byskrif en pyltjie
- Do not penalise for length of arrows.  
*Moenie vir die lengte van die pyltjies penaliseer nie.*
- Deduct 1 mark for any additional force. /Trek 1 punt af vir enige addisionele krag.
- If force(s) do not make contact with body/dot //Indien krag(te) nie met die voorwerp / kolletjie kontak maak nie: Max./Maks:  $\frac{3}{4}$
- If arrows missing//Indien pyltjies uitgelaat is: Max./Maks:  $\frac{3}{4}$

(4)

2.3

<p>For the 2 kg (P) block/<i>Vir die 2 kg (P) blok:</i></p> $\left. \begin{aligned} F_{\text{net}} &= ma \\ T + (-w_{\parallel}) + (-f_k) &= ma \\ T - (w_{\parallel} + f_k) &= ma \end{aligned} \right\} \checkmark \text{Any one/Enige een}$ $T - (2)(9,8)\sin 30^\circ \checkmark - 2,5 \checkmark = 2a \checkmark$ $T - 9,8 - 2,5 = 2a$ $T - 12,3 = 2a \dots\dots\dots(1)$ <p>For the 3 kg (Q) block/<i>Vir die 3 kg (Q) blok:</i></p> $\left. \begin{aligned} F_x + (-T) + (-w_{\parallel}) &= ma \\ F_x - (T + w_{\parallel}) &= ma \end{aligned} \right\} \checkmark \text{Any one/Enige een}$ $[40 \cos 25^\circ \checkmark - T - (3)(9,8)\sin 30^\circ \checkmark] \checkmark = 3a$ $36,25 - T - 14,7 = 3a$ $21,55 - T = 3a \dots\dots\dots(2)$ $9,25 = 5a$ $a = 1,85 \text{ m}\cdot\text{s}^{-2} \checkmark$	<p><b>Marking criteria/Nasienriglyne</b></p> <ul style="list-style-type: none"> <li>• Formula/Formule <math>\checkmark</math></li> <li>• Substitution of /<i>vervanging van</i> <math>w_{\parallel}</math> for/vir 2 kg: (2)(9,8)sin30° <math>\checkmark</math></li> <li>• Substitution of -2,5 N /<i>Vervanging van -2,5 N</i> <math>\checkmark</math></li> <li>• 2a <b>OR/OF</b> 3a <math>\checkmark</math></li> <li>• Calculate/Bereken <math>F_x</math>: 40 cos 25° <math>\checkmark</math> (40 Sin 65°)</li> <li>• Substitution of /<i>vervanging van</i> <math>w_{\parallel}</math> for/vir for 3 kg: (3)(9,8)sin30° <math>\checkmark</math></li> <li>• Left hand side substitution for 3 kg/<i>Linkerkant vervanging vir 3 kg</i> <math>\checkmark</math></li> <li>• Final answer/<i>Finale antwoord:</i> 1,85 m·s<sup>-2</sup> <math>\checkmark</math></li> </ul>
<p><b>Systems Approach (Massless String Approximation / Sisteembenadering (Massalose Tou Benadering) (Max 5/8 marks / Maks 5/8 punte)</b></p> $\left. \begin{aligned} F_{\text{net}} &= ma \\ F_x + (-w_{\parallel}) + (-f_k) &= ma \\ F_x - (w_{\parallel} + f_k) &= ma \end{aligned} \right\} \checkmark \text{Any one/Enige een}$ $40\cos 25^\circ \checkmark - (5)(9,8)\sin 30^\circ \checkmark - 2,5 \checkmark = 5a$ $a = 1,85 \text{ m}\cdot\text{s}^{-2} \checkmark$	

(8)

2.4

Greater than/*groter as*  $\checkmark$   
 $F_{\text{net}}$  increases. / $F_{\text{net}}$  *neem toe.*  $\checkmark$

**ACCEPT/AANVAAR**

There is no friction. /*Daar is geen wrywing nie.*

**OR/OF**

The surface is smooth / *Die oppervlak is glad*

(2)  
**[16]**



**QUESTION 3/VRAAG 3**

- 3.1 (Motion during which) the only force acting is the force of gravity. ✓✓  
(Beweging waartydens) die enigste krag wat inwerk gravitasiekrag is.

**(2 or/of 0)****(2)**

3.2

**Marking criteria/Nasienriglyne:**

- Any appropriate formula for  $\Delta y$ /Enige toepaslike formule vir  $\Delta y$  ✓
- Whole substitution to calculate 5,1 m /Hele vervanging om 5,1 m te bereken ✓
- 40 + answer from calculation/antwoord van berekening ✓
- Final answer/Finale antwoord: 45,10 m ✓ (Accept/aanvaar 45,1 m)

**OPTION 1/OPSIE 1****UPWARDS AS POSITIVE/OPWAARTS AS POSITIEF:**

$$v_f^2 = v_i^2 + 2a\Delta y \quad \checkmark$$

$$0 = (10)^2 + (2)(-9,8)\Delta y \quad \checkmark$$

$$\Delta y = 5,10 \text{ m } (5,102 \text{ m})$$

$$\text{Height} = \underline{40 + 5,10} \quad \checkmark$$

$$= 45,10 \text{ m } \quad \checkmark$$

**DOWNWARDS AS POSITIVE/AFWAARTS AS POSITIEF:**

$$v_f^2 = v_i^2 + 2a\Delta y \quad \checkmark$$

$$0 = (-10)^2 + (2)(9,8)\Delta y \quad \checkmark$$

$$\Delta y = -5,10 \text{ m } (5,102)$$

$$\text{Height} = \underline{40 + 5,10} \quad \checkmark$$

$$= 45,10 \text{ m } \quad \checkmark$$

**OPTION 2/OPSIE 2****UPWARDS AS POSITIVE/OPWAARTS AS POSITIEF:**

$$v_f = v_i + a\Delta t$$

$$0 = (10) + (-9,8)\Delta t$$

$$\Delta t = 1,02 \text{ s}$$

$$\Delta y = v_i\Delta t + \frac{1}{2}a\Delta t^2 \quad \checkmark$$

$$= \underline{(10)(1,02) + \frac{1}{2}(-9,8)(1,02)^2} \quad \checkmark$$

$$= 5,10 \text{ m}$$

$$\text{Height} = \underline{40 + 5,10} \quad \checkmark$$

$$= 45,10 \text{ m } \quad \checkmark$$

Accept swopping of  $v_i$  and  $v_f$   
Aanvaar die omruiling van  $v_i$  en  $v_f$

**OR/OF**

$$\Delta y = \left( \frac{v_i + v_f}{2} \right) \Delta t \quad \checkmark$$

$$= \left( \frac{10 + 0}{2} \right) (1,02) \quad \checkmark$$

$$= 5,10 \text{ m}$$

**DOWNWARDS AS POSITIVE/AFWAARTS AS POSITIEF:**

$$v_f = v_i + a\Delta t$$

$$0 = (-10) + (9,8)\Delta t$$

$$\Delta t = 1,02 \text{ s}$$

$$\Delta y = v_i\Delta t + \frac{1}{2}a\Delta t^2 \quad \checkmark$$

$$= \underline{(-10)(1,02) + \frac{1}{2}(9,8)(1,02)^2} \quad \checkmark$$

$$= 5,10 \text{ m}$$

$$\text{Height} = \underline{40 + 5,10} \quad \checkmark$$

$$= 45,10 \text{ m } \quad \checkmark$$

Accept swopping of  $v_i$  and  $v_f$   
Aanvaar die omruiling van  $v_i$  en  $v_f$

**OPTION 3/OPSIE 3****UPWARDS AS POSITIVE/OPWAARTS AS POSITIEF:**

$$\Delta y = v_i \Delta t + \frac{1}{2} a \Delta t^2$$

$$0 = (10) \Delta t + \frac{1}{2} (-9,8) \Delta t^2$$

$$\Delta t = 2,04 \text{ s} \quad \swarrow \frac{1}{2} \Delta t$$

$$\begin{aligned} \Delta y &= v_i \Delta t + \frac{1}{2} a \Delta t^2 \checkmark \\ &= (10)(1,02) + \frac{1}{2} (-9,8)(1,02)^2 \checkmark \\ &= 5,10 \text{ m} \end{aligned}$$

$$\begin{aligned} \text{Height} &= 40 + \checkmark 5,10 \\ &= 45,10 \text{ m } \checkmark \end{aligned}$$

**DOWNWARDS AS POSITIVE/AFWAARTS AS POSITIEF:**

$$\Delta y = v_i \Delta t + \frac{1}{2} a \Delta t^2$$

$$0 = (-10) \Delta t + \frac{1}{2} (9,8) \Delta t^2$$

$$\Delta t = 2,04 \text{ s} \quad \swarrow \frac{1}{2} \Delta t$$

$$\begin{aligned} \Delta y &= v_i \Delta t + \frac{1}{2} a \Delta t^2 \checkmark \\ &= (-10)(1,02) + \frac{1}{2} (9,8)(1,02)^2 \checkmark \\ &= -5,10 \text{ m} \end{aligned}$$

$$\begin{aligned} \text{Height} &= 40 + \checkmark 5,10 \checkmark \\ &= 45,10 \text{ m } \checkmark \end{aligned}$$

**OPTION 4/OPSIE 4****UPWARDS AS POSITIVE/OPWAARTS AS POSITIEF:**

$$\Delta y = v_i \Delta t + \frac{1}{2} a \Delta t^2$$

$$0 = (10) \Delta t + \frac{1}{2} (-9,8) \Delta t^2$$

$$\Delta t = 2,04 \text{ s} \quad \swarrow \frac{1}{2} \Delta t$$

$$\begin{aligned} \Delta y &= \left( \frac{v_i + v_f}{2} \right) \Delta t \checkmark \\ &= \left( \frac{10 + 0}{2} \right) (1,02) \checkmark \\ &= 5,10 \text{ m} \end{aligned}$$

$$\begin{aligned} \text{Height} &= 40 + \checkmark 5,10 \checkmark \\ &= 45,10 \text{ m } \checkmark \end{aligned}$$

Accept swapping of  $v_i$  and  $v_f$   
Aanvaar die omruiling van  $v_i$  en  $v_f$

**DOWNWARDS AS POSITIVE/AFWAARTS AS POSITIEF:**

$$\Delta y = v_i \Delta t + \frac{1}{2} a \Delta t^2$$

$$0 = (-10) \Delta t + \frac{1}{2} (9,8) \Delta t^2$$

$$\Delta t = 2,04 \text{ s} \quad \swarrow \frac{1}{2} \Delta t$$

$$\begin{aligned} \Delta y &= \left( \frac{v_i + v_f}{2} \right) \Delta t \checkmark \\ &= \left( \frac{-10 + 0}{2} \right) (1,02) \checkmark \\ &= -5,10 \text{ m} \end{aligned}$$

$$\begin{aligned} \text{Height} &= 40 + \checkmark 5,10 \checkmark \\ &= 45,10 \text{ m } \checkmark \end{aligned}$$

Accept swapping of  $v_i$  and  $v_f$   
Aanvaar die omruiling van  $v_i$  en  $v_f$

**OPTION 5/OPSIE 5**

$$E_{(\text{mech/meg})\text{roof/dak}} = E_{(\text{mech/meg})\text{top/bo}}$$

$$(E_p + E_k)_{\text{roof/dak}} = (E_p + E_k)_{\text{top/bo}}$$

$$(mgh + \frac{1}{2}mv^2)_{\text{roof/dak}} = (mgh + \frac{1}{2}mv^2)_{\text{top/bo}}$$

$$[m(9,8)(0) + \frac{1}{2}m(10)^2 = m(9,8)(h) + 0] \checkmark$$

$$h = 5,10 \text{ m}$$

$$\text{Height} = 40 + 5,10 \checkmark$$

$$= 45,10 \text{ m} \checkmark$$

}  $\checkmark$  Any one/Enige een

**OPTION 6/OPSIE 6**

$$W_{\text{net}} = \Delta E_k \checkmark$$

$$w\Delta x \cos\theta = \frac{1}{2}mv_f^2 - \frac{1}{2}mv_i^2$$

$$(m)(9,8)\Delta x \cos 180^\circ = 0 - \frac{1}{2}m(10)^2 \checkmark$$

$$\Delta x = 5,10 \text{ m}$$

$$\text{Height} = 40 + 5,10 \checkmark$$

$$= 45,10 \text{ m} \checkmark$$

**OPTION 7/OPSIE 7**

$$W_{\text{nc}} = \Delta E_p + \Delta E_k \checkmark$$

$$0 = m(9,8)(h_f - 0) + \frac{1}{2}m(0 - 10^2) \checkmark$$

$$h_f = 5,10 \text{ m}$$

$$\text{Height} = 40 + 5,10 \checkmark$$

$$= 45,10 \text{ m} \checkmark$$

**OPTION 8/OPSIE 8****Marking criteria/Nasienriglyne:**

- Appropriate formula/Toegepaste formule  $\checkmark$
- Substitution left/Vervanging links  $\checkmark$
- Substitution right/Vervanging regs  $\checkmark$
- Final answer/Finale antwoord: 45,10 m  $\checkmark$

$$E_{(\text{mech/meg})\text{roof/dak}} = E_{(\text{mech/meg})\text{top/bo}}$$

$$(E_p + E_k)_{\text{roof/dak}} = (E_p + E_k)_{\text{top/bo}}$$

$$(mgh + \frac{1}{2}mv^2)_{\text{roof/dak}} = (mgh + \frac{1}{2}mv^2)_{\text{top/bo}}$$

$$m(9,8)(40) + \frac{1}{2}m(10)^2 \checkmark = m(9,8)(h) + 0 \checkmark$$

$$h = 45,10 \text{ m} \checkmark$$

}  $\checkmark$  Any one/Enige een

(4)

3.3 9,8 m·s<sup>-2</sup>  $\checkmark$  downwards/afwaarts  $\checkmark$ 

(2)

3.4

**Marking criteria/Nasienriglyne**

- Calculation/use of 10,26 m./Berekening/gebruik van 10,26 m. ✓
- Appropriate formula to calculate  $\Delta t$ /Toepaslike formule om  $\Delta t$  te bereken ✓
- Substitution for stone A/Vervanging vir klip A ✓
- Substitution for stone B/Vervanging vir klip B ✓
- Calculating time difference between two stones. /Berekening van tydverskil tussen klippe. ✓
- Final answer/Finale antwoord: 1,34 (s) ✓

**OPTION 1/OPSIE 1****UPWARDS AS POSITIVE/OPWAARTS AS POSITIEF:**

Displacement from roof to meeting point /Verplasing vanaf dak tot ontmoetingspunt =  $-40 + 29,74 = -10,26$  m

**Stone/Klip A**

$$\Delta y_A = v_i \Delta t + \frac{1}{2} a \Delta t^2 \quad \checkmark$$

$$-10,26 \checkmark = 10 \Delta t + \frac{1}{2} (-9,8) \Delta t^2 \quad \checkmark$$

$$\Delta t = 2,79 \text{ s}$$

**Stone/Klip B**

$$\Delta y_B = v_i \Delta t + \frac{1}{2} a \Delta t^2$$

$$-10,26 = 0 + \frac{1}{2} (-9,8) \Delta t^2 \quad \checkmark$$

$$\Delta t = 1,45 \text{ s (1,447 s)}$$

$$x = 2,79 - 1,45 \checkmark = 1,34 \text{ (s)} \quad \checkmark$$

**OR/OF**

$$[-10,26 = 0(2,79 - x) + \frac{1}{2} (-9,8)(2,79 - x)^2 \checkmark] \checkmark$$

$$x = 1,34 \text{ (s)} \quad \checkmark$$

$$\begin{aligned} v_f^2 &= v_i^2 + 2a\Delta y \\ &= 0^2 + 2(-9,8)(-10,26) \\ v_f &= -14,18 \text{ m}\cdot\text{s}^{-1} \end{aligned}$$

$$\begin{aligned} v_f &= v_i + a\Delta t \\ -14,18 &= 0 + (-9,8)\Delta t \checkmark \\ \Delta t &= 1,45 \text{ s} \end{aligned}$$

$$\begin{aligned} x &= 2,79 - 1,45 \checkmark \\ &= 1,34 \text{ (s)} \quad \checkmark \end{aligned}$$

**DOWNWARDS AS POSITIVE/AFWAARTS AS POSITIEF:**

Displacement from roof to meeting point /Verplasing vanaf dak tot ontmoetingspunt =  $40 - 29,74 = 10,26$  m

**Stone/Klip A**

$$\Delta y_A = v_i \Delta t + \frac{1}{2} a \Delta t^2 \quad \checkmark$$

$$10,26 \checkmark = -10 \Delta t + \frac{1}{2} (9,8) \Delta t^2 \quad \checkmark$$

$$\Delta t = 2,79 \text{ s}$$

**Stone/Klip B**

$$\Delta y_B = v_i \Delta t + \frac{1}{2} a \Delta t^2$$

$$10,26 = 0 + \frac{1}{2} (9,8) \Delta t^2 \quad \checkmark$$

$$\Delta t = 1,45 \text{ s (1,447 s)}$$

$$x = 2,79 - 1,45 \checkmark = 1,34 \text{ (s)} \quad \checkmark$$

**OR/OF**

$$[-10,26 = 0(2,79 - x) + \frac{1}{2} (-9,8)(2,79 - x)^2 \checkmark] \checkmark$$

$$x = 1,34 \text{ (s)} \quad \checkmark$$

$$\begin{aligned} v_f^2 &= v_i^2 + 2a\Delta y \\ &= 0^2 + 2(9,8)(10,26) \\ v_f &= 14,18 \text{ m}\cdot\text{s}^{-1} \end{aligned}$$

$$\begin{aligned} v_f &= v_i + a\Delta t \\ 14,18 &= 0 + (9,8)\Delta t \checkmark \\ \Delta t &= 1,45 \text{ s} \end{aligned}$$

$$\begin{aligned} x &= 2,79 - 1,45 \checkmark \\ &= 1,34 \text{ (s)} \quad \checkmark \end{aligned}$$

**OPTION 2/OPSIE 2****UPWARDS AS POSITIVE/OPWAARTS AS POSITIEF:**

Displacement from roof to meeting point /Verplasing vanaf dak tot ontmoetingspunt =  $-40 + 29,74 = -10,26$  m

Displacement of stone A from max height to meeting point/ Verplasing van klip A vanaf maksimum hoogte tot ontmoetingspunt =  $-15,36$  m

**Stone/Klip A**

$$v_f = v_i + a\Delta t$$

$$0 = 10 + (-9,8)\Delta t$$

$$\Delta t = 1,02 \text{ s}$$

$$\Delta y_A = v_i\Delta t + \frac{1}{2}a\Delta t^2 \checkmark$$

$$-15,36 = 0 + \frac{1}{2}(-9,8)\Delta t^2 \checkmark$$

$$\Delta t = 1,77 \text{ s}$$

$$\Delta t_{\text{tot}} = 1,77 + 1,02 = 2,79 \text{ s}$$

**Stone/Klip B**

$$\Delta y_B = v_i\Delta t + \frac{1}{2}a\Delta t^2$$

$$-10,26 \checkmark = 0 + \frac{1}{2}(-9,8)\Delta t^2 \checkmark$$

$$\Delta t = 1,45 \text{ s (1,447 s)}$$

$$x = 2,79 - 1,45 \checkmark = 1,34 \text{ (s)} \checkmark$$

$$v_f^2 = v_i^2 + 2a\Delta y$$

$$= 0^2 + 2(-9,8)(-10,26)$$

$$v_f = -14,18 \text{ m}\cdot\text{s}^{-1}$$

$$v_f = v_i + a\Delta t$$

$$-14,18 = 0 + (-9,8)\Delta t \checkmark$$

$$\Delta t = 1,45 \text{ s}$$

$$x = 2,79 - 1,45 \checkmark$$

$$= 1,34 \text{ (s)} \checkmark$$

**DOWNWARDS AS POSITIVE/AFWAARTS AS POSITIEF:**

Displacement from roof to meeting point /Verplasing vanaf dak tot ontmoetingspunt =  $40 - 29,74 = 10,26$  m  $\checkmark$

Displacement of ball A from max height to meeting point/ Verplasing van bal A vanaf maksimum hoogte tot ontmoetingspunt =  $15,36$  m

**Stone/Klip A**

$$v_f = v_i + a\Delta t$$

$$0 = -10 + (9,8)\Delta t$$

$$\Delta t = 1,02 \text{ s}$$

$$\Delta y_A = v_i\Delta t + \frac{1}{2}a\Delta t^2 \checkmark$$

$$15,36 = 0 + \frac{1}{2}(9,8)\Delta t^2 \checkmark$$

$$\Delta t = 1,77 \text{ s}$$

$$\Delta t_{\text{tot}} = 1,77 + 1,02 = 2,79 \text{ s}$$

**Stone/Klip B**

$$\Delta y_B = v_i\Delta t + \frac{1}{2}a\Delta t^2$$

$$10,26 = 0 + \frac{1}{2}(9,8)\Delta t^2 \checkmark$$

$$\Delta t = 1,45 \text{ s (1,447 s)}$$

$$x = 2,79 - 1,45 \checkmark = 1,34 \text{ (s)} \checkmark$$

$$v_f^2 = v_i^2 + 2a\Delta y$$

$$= 0^2 + 2(9,8)(10,26)$$

$$v_f = 14,18 \text{ m}\cdot\text{s}^{-1}$$

$$v_f = v_i + a\Delta t$$

$$14,18 = 0 + (9,8)\Delta t \checkmark$$

$$\Delta t = 1,45 \text{ s}$$

$$x = 2,79 - 1,45 \checkmark$$

$$= 1,34 \text{ (s)} \checkmark$$

**OPTION 3/OPSIE 3****UPWARDS AS POSITIVE/OPWAARTS AS POSITIEF:**

Displacement of stones A and B from roof to meeting point/*Verplasing van klippe A en B vanaf dak tot by ontmoetingspunt* =  $-40 + 29,74$   
 =  $-10,26$  m

**Stone/Klip A**

$$v_f = v_i + a\Delta t$$

$$0 = 10 + (-9,8)\Delta t$$

$$\Delta t = 1,02 \text{ s}$$

$$\Delta y_A = v_i\Delta t + \frac{1}{2}a\Delta t^2 \checkmark$$

$$-10,26 \checkmark = \underline{-10 + \frac{1}{2}(-9,8)\Delta t^2} \checkmark$$

$$\Delta t = 0,75 \text{ s}$$

$$\Delta t_{\text{tot}} = 1,02 + 1,02 + 0,75 = 2,79 \text{ s}$$

**Stone/Klip B**

$$\Delta y_B = v_i\Delta t + \frac{1}{2}a\Delta t^2$$

$$\underline{-10,26 = 0 + \frac{1}{2}(-9,8)\Delta t^2} \checkmark$$

$$\Delta t = 1,45 \text{ s (1,447 s)}$$

$$x = 2,79 - 1,45 \checkmark = 1,34 \text{ (s)} \checkmark$$

$$v_f^2 = v_i^2 + 2a\Delta y$$

$$= 0^2 + 2(-9,8)(-10,26)$$

$$v_f = -14,18 \text{ m}\cdot\text{s}^{-1}$$

$$v_f = v_i + a\Delta t$$

$$\underline{-14,18 = 0 + (-9,8)\Delta t} \checkmark$$

$$\Delta t = 1,45 \text{ s}$$

$$x = 2,79 - 1,45 \checkmark$$

$$= 1,34 \text{ (s)} \checkmark$$

**DOWNWARDS AS POSITIVE/AFWAARTS AS POSITIEF:**

Displacement of stones A and B from roof to meeting point/*Verplasing van klippe A en B vanaf dak tot by ontmoetingspunt* =  $40 - 29,74 = 10,26$  m

**Stone/Klip A**

$$v_f = v_i + a\Delta t$$

$$0 = -10 + (9,8)\Delta t$$

$$\Delta t = 1,02 \text{ s}$$

$$\Delta y_A = v_i\Delta t + \frac{1}{2}a\Delta t^2 \checkmark$$

$$10,26 \checkmark = \underline{10 + \frac{1}{2}(9,8)\Delta t^2} \checkmark$$

$$\Delta t = 0,75 \text{ s}$$

$$\Delta t_{\text{tot}} = 1,02 + 1,02 + 0,75 = 2,79 \text{ s}$$

**Stone/Klip B**

$$\Delta y_B = v_i\Delta t + \frac{1}{2}a\Delta t^2$$

$$\underline{10,26 = 0 + \frac{1}{2}(9,8)\Delta t^2} \checkmark$$

$$\Delta t = 1,45 \text{ s (1,447 s)}$$

$$x = 2,79 - 1,45 \checkmark = 1,34 \text{ (s)} \checkmark$$

$$v_f^2 = v_i^2 + 2a\Delta y$$

$$= 0^2 + 2(9,8)(10,26)$$

$$v_f = 14,18 \text{ m}\cdot\text{s}^{-1}$$

$$v_f = v_i + a\Delta t$$

$$\underline{14,18 = 0 + (9,8)\Delta t} \checkmark$$

$$\Delta t = 1,45 \text{ s}$$

$$x = 2,79 - 1,45 \checkmark$$

$$= 1,34 \text{ (s)} \checkmark$$

**OPTION 4/OPSIE 4****UPWARDS AS POSITIVE/OPWAARTS AS POSITIEF:**

Displacement from roof to meeting point /Verplasing vanaf dak tot ontmoetingspunt =  $-40 + 29,74 = -10,26$  m

**Stone/Klip A**

$$\Delta y_A = v_i \Delta t + \frac{1}{2} a \Delta t^2$$

$$-5,10 = 0 + \frac{1}{2}(-9,8)\Delta t^2$$

$$\Delta t = 1,02 \text{ s}$$

$$\Delta y_A = v_i \Delta t + \frac{1}{2} a \Delta t^2 \checkmark$$

$$-10,26 \checkmark = \underline{-10 + \frac{1}{2}(-9,8)\Delta t^2} \checkmark$$

$$\Delta t = 0,75 \text{ s}$$

$$\Delta t_{\text{tot}} = 1,02 + 1,02 + 0,75 = 2,79 \text{ s}$$

**Stone/Klip B**

$$\Delta y_B = v_i \Delta t + \frac{1}{2} a \Delta t^2$$

$$\underline{-10,26 = 0 + \frac{1}{2}(-9,8)\Delta t^2} \checkmark$$

$$\Delta t = 1,45 \text{ s (1,447 s)}$$

$$x = 2,79 - 1,45 \checkmark = 1,34 \text{ (s)} \checkmark$$

$$v_f^2 = v_i^2 + 2a\Delta y$$

$$= 0^2 + 2(-9,8)(-10,26)$$

$$v_f = -14,18 \text{ m}\cdot\text{s}^{-1}$$

$$v_f = v_i + a\Delta t$$

$$\underline{-14,18 = 0 + (-9,8)\Delta t} \checkmark$$

$$\Delta t = 1,45 \text{ s}$$

$$x = 2,79 - 1,45 \checkmark$$

$$= 1,34 \text{ (s)} \checkmark$$

**DOWNWARDS AS POSITIVE/AFWAARTS AS POSITIEF:**

Displacement from roof to meeting point /verplasing vanaf dak tot by ontmoetingspunt =  $40 - 29,74 = 10,26$  m

**Stone/Klip A**

$$\Delta y_A = v_i \Delta t + \frac{1}{2} a \Delta t^2$$

$$5,10 = 0 + \frac{1}{2}(9,8)\Delta t^2$$

$$\Delta t = 1,02 \text{ s}$$

$$\Delta y_A = v_i \Delta t + \frac{1}{2} a \Delta t^2 \checkmark$$

$$10,26 \checkmark = \underline{10 + \frac{1}{2}(9,8)\Delta t^2} \checkmark$$

$$\Delta t = 0,75 \text{ s}$$

$$\Delta t_{\text{tot}} = 1,02 + 1,02 + 0,75 = 2,79 \text{ s}$$

**Stone/Klip B**

$$\Delta y_B = v_i \Delta t + \frac{1}{2} a \Delta t^2$$

$$\underline{10,26 = 0 + \frac{1}{2}(9,8)\Delta t^2} \checkmark$$

$$\Delta t = 1,45 \text{ s (1,447 s)}$$

$$x = 2,79 - 1,45 \checkmark = 1,34 \text{ (s)} \checkmark$$

$$v_f^2 = v_i^2 + 2a\Delta y$$

$$= 0^2 + 2(9,8)(10,26)$$

$$v_f = 14,18 \text{ m}\cdot\text{s}^{-1}$$

$$v_f = v_i + a\Delta t$$

$$\underline{14,18 = 0 + (9,8)\Delta t} \checkmark$$

$$\Delta t = 1,45 \text{ s}$$

$$x = 2,79 - 1,45 \checkmark$$

$$= 1,34 \text{ (s)} \checkmark$$

**OPTION 5/OPSIE 5****UPWARDS AS POSITIVE/OPWAARTS AS POSITIEF:**

Displacement from roof to meeting point /Verplasing vanaf dak tot ontmoetingspunt =  $-40 + 29,74 = -10,26$  m

Displacement of stone A from max height to meeting point/ Verplasing van klip A vanaf maksimum hoogte tot ontmoetingspunt =  $-15,36$  m

**Stone/Klip A**

$$v_f^2 = v_i^2 + 2a\Delta y$$

$$v_f^2 = (0)^2 + (2)(-9,8)(-15,36)$$

$$v_f = -17,35 \text{ m}\cdot\text{s}^{-1}$$

$$v_f = v_i + a\Delta t$$

$$\underline{-17,35 = 0 + (-9,8)\Delta t} \checkmark$$

$$\Delta t = 1,77 \text{ s}$$

$$\Delta t_{\text{tot}} = 1,02 + 1,77 = 2,79 \text{ (s)}$$

**Stone/Klip B**

$$\Delta y_B = v_i\Delta t + \frac{1}{2}a\Delta t^2$$

$$\underline{-10,26 \checkmark = 0 + \frac{1}{2}(-9,8)\Delta t^2} \checkmark$$

$$\Delta t = 1,45 \text{ s (1,447 s)}$$

$$x = 2,79 - 1,45 \checkmark = 1,34 \text{ (s)} \checkmark$$

$$v_f^2 = v_i^2 + 2a\Delta y$$

$$= 0^2 + 2(-9,8)(-10,26)$$

$$v_f = -14,18 \text{ m}\cdot\text{s}^{-1}$$

$$v_f = v_i + a\Delta t$$

$$\underline{-14,18 = 0 + (-9,8)\Delta t} \checkmark$$

$$\Delta t = 1,45 \text{ s}$$

$$x = 2,79 - 1,45 \checkmark$$

$$= 1,34 \text{ (s)} \checkmark$$

**DOWNWARDS AS POSITIVE/AFWAARTS AS POSITIEF:**

Displacement from roof to meeting point /Verplasing vanaf dak tot ontmoetingspunt =  $40 - 29,74 = 10,26$  m

Displacement of stone A from max height to meeting point/ Verplasing van klip A vanaf maksimum hoogte tot ontmoetingspunt =  $15,36$  m

**Stone/Klip A**

$$v_f^2 = v_i^2 + 2a\Delta y$$

$$v_f^2 = (0)^2 + (2)(9,8)(15,36)$$

$$v_f = 17,35 \text{ m}\cdot\text{s}^{-1}$$

$$v_f = v_i + a\Delta t$$

$$\underline{17,35 = 0 + (9,8)\Delta t} \checkmark$$

$$\Delta t = 1,77 \text{ s}$$

$$\Delta t_{\text{tot}} = 1,02 + 1,77 = 2,79 \text{ (s)}$$

**Stone/Klip B**

$$\Delta y_B = v_i\Delta t + \frac{1}{2}a\Delta t^2$$

$$\underline{10,26 \checkmark = 0 + \frac{1}{2}(9,8)\Delta t^2} \checkmark$$

$$\Delta t = 1,45 \text{ s (1,447 s)}$$

$$x = 2,79 - 1,45 \checkmark = 1,34 \text{ (s)} \checkmark$$

$$v_f^2 = v_i^2 + 2a\Delta y$$

$$= 0^2 + 2(9,8)(10,26)$$

$$v_f = 14,18 \text{ m}\cdot\text{s}^{-1}$$

$$v_f = v_i + a\Delta t$$

$$\underline{14,18 = 0 + (9,8)\Delta t} \checkmark$$

$$\Delta t = 1,45 \text{ s}$$

$$x = 2,79 - 1,45 \checkmark$$

$$= 1,34 \text{ (s)} \checkmark$$



**OPTION 6/OPSIE 6**

**UPWARDS AS POSITIVE/OPWAARTS AS POSITIEF:**

Displacement from roof to meeting point/Verplasing vanaf dak tot by ontmoetingspunt =  $-40 + 29,74 = -10,26$  m

**Stone/Klip A**

$$v_f^2 = v_i^2 + 2a\Delta y$$

$$v_f^2 = (-10)^2 + (2)(-9,8)(-10,26)$$

$$v_f = -17,35 \text{ m}\cdot\text{s}^{-1}$$

$$v_f = v_i + a\Delta t$$

$$\underline{-17,35 = -10 + (-9,8)\Delta t} \checkmark$$

$$\Delta t = 0,75 \text{ s}$$

$$\text{Ball A: } \Delta t = 1,02 + 1,02 + 0,75 = 2,79 \text{ (s)}$$

**Stone/Klip B**

$$\Delta y_B = v_i\Delta t + \frac{1}{2}a\Delta t^2$$

$$\underline{-10,26 \checkmark = 0 + \frac{1}{2}(-9,8)\Delta t^2} \checkmark$$

$$\Delta t = 1,45 \text{ s (1,447 s)}$$

$$x = 2,79 - 1,45 \checkmark = 1,34 \text{ (s)} \checkmark$$

$$v_f^2 = v_i^2 + 2a\Delta y$$

$$= 0^2 + 2(-9,8)(-10,26)$$

$$v_f = -14,18 \text{ m}\cdot\text{s}^{-1}$$

$$v_f = v_i + a\Delta t$$

$$\underline{-14,18 = 0 + (-9,8)\Delta t} \checkmark$$

$$\Delta t = 1,45 \text{ s}$$

$$x = 2,79 - 1,45 \checkmark$$

$$= 1,34 \text{ (s)} \checkmark$$

**DOWNWARDS AS POSITIVE/AFWAARTS AS POSITIEF:**

Displacement from roof to meeting point/Verplasing vanaf dak tot by ontmoetingspunt =  $40 - 29,74 = 10,26$  m

**Stone/Klip A**

$$v_f^2 = v_i^2 + 2a\Delta y$$

$$v_f^2 = [(10)^2 + (2)(9,8)(10,26)]$$

$$v_f = 17,35 \text{ m}\cdot\text{s}^{-1}$$

$$v_f = v_i + a\Delta t$$

$$\underline{17,35 = 10 + (9,8)\Delta t} \checkmark$$

$$\Delta t = 0,75 \text{ s}$$

$$\text{Ball A: } \Delta t = 1,02 + 1,02 + 0,75 = 2,79 \text{ (s)}$$

**Stone/Klip B**

$$\Delta y_B = v_i\Delta t + \frac{1}{2}a\Delta t^2$$

$$\underline{10,26 \checkmark = 0 + \frac{1}{2}(9,8)\Delta t^2} \checkmark$$

$$\Delta t = 1,45 \text{ s (1,447 s)}$$

$$x = 2,79 - 1,45 \checkmark = 1,34 \text{ (s)} \checkmark$$

$$v_f^2 = v_i^2 + 2a\Delta y$$

$$= 0^2 + 2(9,8)(10,26)$$

$$v_f = 14,18 \text{ m}\cdot\text{s}^{-1}$$

$$v_f = v_i + a\Delta t$$

$$\underline{14,18 = 0 + (9,8)\Delta t} \checkmark$$

$$\Delta t = 1,45 \text{ s}$$

$$x = 2,79 - 1,45 \checkmark$$

$$= 1,34 \text{ (s)} \checkmark$$

(6)

3.5.1 d  $\checkmark$  **Accept / Aanvaar** ( 0 – e; 0 – d; d – e)

(1)

3.5.2 a  $\checkmark$

(1)

3.5.3 f  $\checkmark$

(1)

3.5.4 c  $\checkmark$

(1)

**[18]**

**QUESTION 4/VRAAG 4**

4.1

**NOTE:** -1 mark for each key word/phrase omitted in the correct context.**LET WEL:** -1 punt vir elke sleutelwoord/frase weggelaat in die korrekte konteks.Isolated system is a system on which the resultant/net external force is zero. ✓✓*Geïsoleerde sisteem is 'n sisteem waarop die resultante / netto eksterne krag nul is.***OR/OF**

Isolated system is one that has no net / external force acting on it.

*'n Geïsoleerde stelsel is een wat geen netto eksterne krag het wat daarop inwerk nie.*

(2)

4.2.1

$$p = mv \checkmark$$

$$24 = m (480) \checkmark$$

$$m = 0,05 \text{ kg} \checkmark$$

Note: p and v must have the same sign

*Let wel: p en v moet dieselfde tekens hê*

(3)

4.2.2

**Marking criteria/Nasienriglyne**

- Appropriate formula including  $F_{\text{net}}$  or  $W_{\text{net}}$ . / *Toepaslike formule wat  $F_{\text{net}}$  of  $W_{\text{net}}$  insluit.* ✓
- Substitutions/Vervangings ✓✓
- Final answer/Finale antwoord: 2 000 N ✓
- Correct direction/Korrekte rigting: west or left/Wes of links ✓

**POSITIVE MARKING FROM QUESTION 4.2.1****POSITIEWE NASIEN VANAF VRAAG 4.2.1****OPTION 1/OPSIE 1**

$$F_{\text{net}}\Delta t = \Delta p$$

$$F_{\text{net}}\Delta t = (p_{\text{bullet}})_f - (p_{\text{bullet}})_i$$

$$F_{\text{net}}\Delta t = (mv_{\text{bullet}})_f - (mv_{\text{bullet}})_i$$

$$F_{\text{net}}(0,01) \checkmark = (0,05)(80) - 24 \checkmark \text{ or/of } (0,05)(80) - (0,05)(480)$$

$$F_{\text{net}} = -2\,000 \text{ N}$$

$$F_{\text{net}} = 2\,000 \text{ N} \checkmark \text{ west/wes} \checkmark$$

**OPTION 2/OPSIE 2**

$$v_f = v_i + a\Delta t$$

$$80 = 480 + a(0,01) \checkmark$$

$$a = -40\,000 \text{ m}\cdot\text{s}^{-2}$$

$$F_{\text{net}} = ma \checkmark$$

$$= (0,05)(-40\,000) \checkmark$$

$$= -2\,000 \text{ N}$$

$$F_{\text{net}} = 2\,000 \text{ N} \checkmark \text{ west/wes} \checkmark$$

**OPTION 3/OPSIE 3**

$$\Delta x = \left( \frac{v_i + v_f}{2} \right) \Delta t$$

$$= \frac{480 + 80}{2} (0,01)$$

$$= 2,80 \text{ m}$$

$$v_f^2 = v_i^2 + 2a\Delta x$$

$$(80)^2 = (480)^2 + 2a(2,80) \checkmark$$

$$a = -40\,000 \text{ m}\cdot\text{s}^{-2}$$

$$F_{\text{net}} = ma \checkmark$$

$$= (0,05)(-40\,000) \checkmark$$

$$= -2\,000 \text{ N}$$

$$F_{\text{net}} = 2\,000 \text{ N} \checkmark \text{ west/wes} \checkmark$$

$$W_{\text{net}} = \Delta K \checkmark$$

$$F_{\text{net}} \Delta x \cos \theta = \frac{1}{2} m v_f^2 - \frac{1}{2} m v_i^2$$

$$F_{\text{net}} (2,80) \cos 0^\circ \checkmark = \frac{1}{2} (0,05) (80^2 - 480^2) \checkmark$$

$$F_{\text{net}} = -2\,000 \text{ N}$$

$$F_{\text{net}} = 2\,000 \text{ N} \checkmark \text{ west/wes} \checkmark$$

**OR/OF**

$$F_{\text{net}} (2,80) \cos 180^\circ \checkmark = \frac{1}{2} (0,05) (80^2 - 480^2) \checkmark$$

$$F_{\text{net}} = 2\,000 \text{ N} \checkmark \text{ west/wes} \checkmark$$

(5)  
[10]

**QUESTION 5**

5.1

**Note:** -1 mark for each key word/phrase omitted in the correct context.  
**Let Wel:** -1 punt vir elke sleutelwoord/frase weggelaat in die korrekte konteks.  
**IF:** The word "work" is omitted - 0 marks.  
**INDIEN:** Die woord "arbeid" uitgelaat is - 0 punte.

A *conservative force* is a force for which the work done (in moving an object between two points) is independent of the path taken. ✓✓

'n *Konserwatiewe krag* is 'n krag waarvoor die arbeid wat verrig is (om 'n voorwerp tussen twee punte te beweeg) onafhanklik is van die pad wat gevat word.

**OR/OF**

A conservative force is a force for which the work done in moving an object in a closed path is zero.

'n *Konserwatiewe krag* is 'n krag waarvoor die arbeid verrig om 'n voorwerp in 'n geslote pad te beweeg, nul is.

(2)

5.2 Gravitational (force)/Gravitasiekrag ✓

**ACCEPT/AANVAAR:** Gravitation /Gravity /Gravitasie /Weight /Gewig

(1)

5.3 No/Nee ✓

There is friction/non-conservative force (doing work)/It is not isolated system. ✓

Daar is wrywing/nie konserwatiewe krag (wat arbeid verrig)./Dit is nie 'n geïsoleerde sisteem nie.

**OR/OF**

The net work done by the non-conservative forces is not zero./Die netto arbeid deur die nie-konserwatiewe kragte is nie nul nie. ✓

(2)

5.4

<b>OPTION 1/OPSIE 1</b>	<b>OPTION 2/OPSIE 2</b>
$E_p = mgh \checkmark$ $= (1,8)(9,8)(1,5) \checkmark$ $= 26,46 \text{ J} \checkmark$	$W_w = -\Delta E_p \checkmark$ $(1,8)(9,8)(h - 0)\cos 180^\circ = -(E_{pA} - E_{p(\text{ground})})$ $(1,8)(9,8)(1,5)(-1) = -E_{pA} \checkmark$ $E_p = 26,46 \text{ J} \checkmark$  <b>OR/OF</b> $W = F\Delta x \cos\theta$ $= mg\Delta h \cos\theta$ $= (1,8)(9,8)(1,5)\cos 0^\circ \checkmark$ $= 26,46 \text{ J} \checkmark$

(3)

5.5

**POSITIVE MARKING FROM QUESTION 5.4 /****POSITIEWE NASIEN VANAF VRAAG 5.4****OPTION 1/OPSIE 1**

$$W_{nc} = \Delta K + \Delta U$$

$$W_f = \frac{1}{2}m(v_f^2 - v_i^2) + mg(h_f - h_i) \checkmark \text{ Any one/Enige een}$$

$$= \frac{1}{2}(1,8)(4^2 - 0,95^2) \checkmark + (0 - 26,46) \checkmark$$

$$= -12,87 \text{ J} \checkmark$$

**OPTION 2/OPSIE 2**

$$W_{net} = \Delta K$$

$$W_f + W_g = \frac{1}{2}mv_f^2 - \frac{1}{2}mv_i^2 \checkmark \text{ Any one/Enige een}$$

$$W_f + mgh = \frac{1}{2}m(v_f^2 - v_i^2)$$

$$W_f + mgh = \frac{1}{2}mv_f^2 - \frac{1}{2}mv_i^2$$

$$W_f + 26,46 \checkmark = \frac{1}{2}(1,8)[(4)^2 - (0,95)^2] \checkmark$$

$$W_f = -12,87 \text{ J} \text{ (- 12,872 J)} \checkmark$$

**OPTION 3/OPSIE 3**

$$E_{(\text{mech/meg})A} = E_{(\text{mech})B} - W_f \checkmark \text{ Any one/Enige een}$$

$$(E_p + E_k)_A = (E_p + E_k)_B - W_f$$

$$(mgh + \frac{1}{2}mv^2)_A = (mgh + \frac{1}{2}mv^2)_B - W_f$$

$$26,46 + \frac{1}{2}(1,8)(0,95^2) \checkmark = 0 + \frac{1}{2}(1,8)(4^2) - W_f \checkmark$$

$$W_f = -12,87 \text{ J} \checkmark$$

(4)

5.6

$$W_{net} = 0 \text{ (J) / zero} \checkmark$$

(1)

**[13]****QUESTION 6/VRAAG 6**6.1 Doppler effect/Doppler-effek  $\checkmark$ 

(1)

6.2 (Q): (records sounds with) longer period/ longer time per wave / lower frequency.

(Q): (teken klank aan met) langer periode / langer tyd per golf / laer frekwensie.

**OR/OF**P: (records sounds with) shorter period/ shorter time per wave / higher frequency.  $\checkmark$ 

P: (teken klank aan met) korter periode/ korter tyd per golf / hoër frekwensie.

**ACCEPT/AANVAAR**

(Q): longer wavelength. /P: shorter wavelength.

(Q): langer golflengte./P: korter golflengte het.

(1)

6.3 **OPTION 1/OPSIE 1**

$$f = \frac{1}{T} \checkmark = \frac{1}{17 \times 10^{-4}} \checkmark = 5,88 \times 10^2 = 588,24 \text{ Hz} \checkmark$$

**OPTION 2/OPSIE 2**

$$\text{speed} = \frac{\text{distance}}{\text{time}}$$

$$340 = \frac{\text{distance}}{25,5 \times 10^{-4}}$$

$$\text{Distance} = 0,867 \text{ m}$$

$$\text{Distance} = 1 \frac{1}{2} \lambda$$

$$\therefore \lambda = 0,578 \text{ m}$$

$$v = f\lambda \checkmark \downarrow$$

$$340 = f(0,578) \checkmark$$

$$f = 588,24 \text{ Hz} \checkmark$$

**OPTION 3/OPSIE 3**

$$v = \frac{\lambda}{T}$$

$$340 = \frac{\lambda}{17 \times 10^{-4}}$$

$$\therefore \lambda = 0,578 \text{ m}$$

$$v = f\lambda \checkmark \downarrow$$

$$340 = f(0,578) \checkmark$$

$$f = 588,24 \text{ Hz} \checkmark$$

(3)

6.4 **POSITIVE MARKING FROM QUESTIONS 6.2 AND 6.3.****POSITIEWE NASIEN VANAF VRAE 6.2 EN 6.3**

Do not penalise if  $10^{-4}$  is again omitted. *!Moenie penaliseer indien  $10^{-4}$  weer uitgelaat is nie.*

**OPTION 1/OPSIE 1**

$$f = \frac{1}{18 \times 10^{-4}} \checkmark = 5,56 \times 10^2 = 555,56 \text{ Hz}$$

$$f_L = \frac{v \pm v_L}{v \pm v_s} f_s \checkmark \quad \text{OR/OF} \quad f_L = \frac{v}{v + v_s} f_s$$

$$555,56 \checkmark = \left( \frac{340}{340 + v} \right) 588,24 \checkmark$$

$$v = 20 \text{ m} \cdot \text{s}^{-1} \checkmark$$

$$\text{Range/Gebied } 19,57 - 20,09 \text{ m} \cdot \text{s}^{-1}$$

**OPTION 2/OPSIE 2**

$$f_L = \frac{1}{18 \times 10^{-4}} \checkmark$$

$$f_L = \frac{v \pm v_L}{v \pm v_s} f_s \checkmark \quad \text{OR/OF} \quad f_L = \frac{v}{v + v_s} f_s$$

$$\frac{1}{18 \times 10^{-4}} \checkmark = \left( \frac{340}{340 + v} \right) \frac{1}{17 \times 10^{-4}} \checkmark$$

$$v = 20 \text{ m} \cdot \text{s}^{-1} \checkmark$$

$$\text{Range/Gebied } 19,57 - 20,09 \text{ m} \cdot \text{s}^{-1}$$

(6)  
[11]

**QUESTION 7/VRAAG 7**

7.1.1 Positive/Positief ✓ (1)

7.1.2 **Marking criteria/Nasienriglyne:**

- Appropriate formula /Toepaslike formule ✓
- Whole substitution Hele vervanging ✓
- Final answer/finale antwoord:  $2,26 \times 10^{-6} \text{ C}$  ✓

<p><b>OPTION 1/OPSIE 1</b></p> $F = \frac{kQ_1Q_2}{r^2} \checkmark$ $3,05 = \frac{(9 \times 10^9)(6 \times 10^{-6})Q}{0,2^2} \checkmark$ $Q = 2,26 \times 10^{-6} \text{ C} \checkmark$ <p style="text-align: center;">(2,259 x 10<sup>-6</sup> C)</p>	<p><b>OPTION 2/OPSIE 2</b></p> $E = \frac{kQ}{r^2}$ $= \frac{(9 \times 10^9)(6 \times 10^{-6})}{0,2^2}$ $= 1,35 \times 10^6 \text{ N} \cdot \text{C}^{-1}$ $F = Eq \checkmark$ $3,05 = (1,35 \times 10^6)q \checkmark$ $q = 2,26 \times 10^{-6} \text{ N} \checkmark$
--	---

(3)

7.1.3

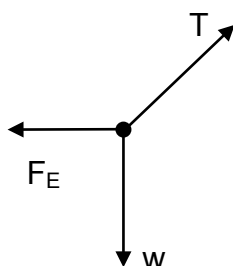

<b>Accepted labels/Aanvaarde benoemings</b>	
W ✓	$F_g / F_w / \text{weight} / mg / \text{gravitational force}$ $F_g / F_w / \text{gewig} / mg / \text{gravitasiekrag}$
T ✓	$F_T / \text{tension} / \text{spanning}$
$F_E / F \checkmark$	Electrostatic force/ Coulomb force/ $F_{E \text{ Field}} / F_{x \text{ on } Y} /$ 3,05 N <i>Elektrostatiese krag/ Coulombkrag</i>

**Notes/Aantekeninge**

- Mark is awarded for label and arrow. /Punt word toegeken vir byskrif en pyltjie.
- Do not penalise for length of arrows.  
*Moenie vir die lengte van die pyltjies penaliseer nie.*
- Deduct 1 mark for any additional force /Trek 1 punt af vir enige addisionele krag
- If force(s) do not make contact with dot /Indien krag(te) nie met die kolletjie kontak maak nie: Max/Maks  $\frac{2}{3}$
- If arrows missing/Indien pyltjies uitgelaat word: Max/Maks  $\frac{2}{3}$

(3)

7.1.4

$F_{\text{net}} = 0$ $F_E = T \sin 10^\circ$ $F_E = T \cos 80^\circ$ $[3,05 = T \sin 10^\circ \checkmark] \checkmark$	<p style="text-align: right;">[IF /INDIEN <math>T \cos 10^\circ = 3,05 (\frac{1}{3})</math>]</p>
<p><b>OR/OF</b></p> $[3,05 = T \cos 80^\circ \checkmark] \checkmark$ $T = 17,56 \text{ N} \checkmark (17,564 \text{ N})$	<p style="text-align: right;">[IF/INDIEN <math>T \sin 80^\circ = 3,05 (\frac{1}{3})</math>]</p>

(3)

7.2.1

**Marking criteria/Nasienriglyne**

-1 mark for each key word/phrase omitted in the correct context.  
-1 punt vir elke sleutelwoord/frase weggelaat in die korrekte konteks.

The electric field at a point is the (electrostatic) force experienced per unit positive charge placed at that point. ✓✓

Die elektriese veld by 'n punt is die (elektrostatiese) krag wat per positiewe eenheidslading wat by die punt geplaas is, ondervind word.

[IF the word “unit” or phrase “positive charge” is omitted in this definition: -1 for each **INDIEN** die woord “eenheid” of frase “positiewe lading” uitgelaat is in hierdie definisie: -1 vir elk]

**OR/OF**

The electric field at a point is the (electrostatic) force experienced by a UNIT positive charge placed at that point. ✓✓

Die elektriese veld by 'n punt is die (elektrostatiese) krag wat deur 'n positiewe EENHEIDSlading wat by die punt geplaas is, ondervind word.

[If “UNIT” is omitted in this definition, then 0 marks.

Indien “EENHEIDS” uitgelaat word in hierdie definisie, dan 0 punte.]

(2)

7.2.2

**OPTION 1/OPSIE 1**

Electric field at **M** due to **A** ( $+2 \times 10^{-5}$  C):

$$E_A = \frac{kQ}{r^2} \checkmark$$

$$= 9 \times 10^9 \frac{(2 \times 10^{-5})}{(0,2)^2} \checkmark$$

$$= 4,5 \times 10^6 \text{ N} \cdot \text{C}^{-1}$$

Electric field at **M** due to **B** ( $-4 \times 10^{-5}$  C):

$$E_B = \frac{kQ}{r^2} \quad \text{OR/OF} \quad q_B = 2q_A$$

$$= 9 \times 10^9 \frac{(4 \times 10^{-5})}{(0,2)^2} \checkmark \quad E_B = 2E_A \checkmark$$

$$= 9 \times 10^6 \text{ N} \cdot \text{C}^{-1} \quad = 9 \times 10^6 \text{ N} \cdot \text{C}^{-1}$$

$$E_{\text{net at M}} = E_A + E_B$$

$$= (4,5 \times 10^6 + 9 \times 10^6) \checkmark$$

$$= 1,35 \times 10^7 \text{ N} \cdot \text{C}^{-1} \checkmark \text{ to the right/na regs/towards B/na B}$$

/away from A / weg vanaf A ✓

**OPTION 2/OPSIE 2**

Net electrostatic force at **M** / Netto elektrostatische krag by **M**

$$F_{\text{net}} = \frac{kQ_1Q_2}{r^2} + \frac{kQ_1Q_2}{r^2}$$

$$= \frac{(9 \times 10^9)(2 \times 10^{-5})q}{(0,2)^2} + \frac{(9 \times 10^9)(4 \times 10^{-5})q}{(0,2)^2} \checkmark \text{ (any one/ enige een)}$$

$$= 4,5 \times 10^6 q + 9 \times 10^6 q$$

$$= 1,35 \times 10^7 q \text{ N}$$

If/Indien  $F = \frac{kQ}{r^2}$  Max/Maks  $\frac{2}{6}$

$$F_{\text{net}} = E_{\text{net}}q \checkmark$$

$$1,35 \times 10^7 q \checkmark = E_{\text{net}}q$$

$$E_{\text{net}} = 1,35 \times 10^7 \text{ N} \cdot \text{C}^{-1} \checkmark \text{ to the right/na regs } \checkmark \text{ /towards B / na B}$$

(6)  
[18]

**QUESTION 8/VRAAG 8**

- 8.1 (Maximum) energy provided (work done) ✓ by a battery per coulomb / unit charge passing through it. ✓  
 (Maksimum) energie verskaf (arbeid verrig) deur 'n battery per coulomb/eenheidlading wat daardeur beweeg.

**ACCEPT/AANVAAR:**

The reading on a voltmeter connected across a battery when there is no current/ in an open circuit. ✓✓

Lesing op 'n voltmeter oor 'n battery as daar geen stroom is nie

(2)

- 8.2 13 V ✓

(1)

- 8.3.1

$R = \frac{V}{I} \checkmark$ $5,6 = \frac{10,5}{I} \checkmark$ $I = 1,88 \text{ A} \checkmark (1,875 \text{ A})$	<p><b>Marking criteria/Nasienriglyne:</b></p> <ul style="list-style-type: none"> <li>• Appropriate formula/Toepaslike formule ✓</li> <li>• Whole substitution/Hele vervanging ✓</li> <li>• Final answer/Finale antwoord: 1,88 A ✓</li> </ul>
--	--

(3)

- 8.3.2

<b>POSITIVE MARKING FROM QUESTION 8.3.1.</b>	
<b>POSITIEWE NASIEN VANAF VRAAG 8.3.1</b>	
<p><b>OPTION 1</b></p> $P = VI \checkmark$ $= (10,5)(1,88) \checkmark$ $= 19,74 \text{ W} \checkmark (19,688 \text{ W})$	<p><b>OPTION 2</b></p> $P = I^2R \checkmark$ $= (1,88)^2(5,6) \checkmark$ $= 19,79 \text{ W} \checkmark (19,688 \text{ W})$
<p><b>OPTION 3</b></p> $P = \frac{V^2}{R} \checkmark$ $= \frac{10,5^2}{5,6} \checkmark$ $= 19,69 \text{ W} \checkmark (19,688 \text{ W})$	

(3)

- 8.3.3

<b>POSITIVE MARKING FROM QUESTIONS 8.2 AND 8.3.1.</b>	
<b>POSITIEWE NASIEN VANAF VRAAG 8.2 EN 8.3.1</b>	
<p><b>OPTION 1/OPSIE 1</b></p> $\mathcal{E} = I(R + r) \checkmark$ $13 = 1,88(5,6 + r) \checkmark$ $r = 1,31 \Omega \checkmark (1,31 - 1,33 \Omega)$	<p><b>OPTION 2/OPSIE 2</b></p> $r = \frac{V_{\text{internal}}}{I} \checkmark$ $= \frac{2,5}{1,88} \checkmark$ $= 1,33 \Omega \checkmark (1,31 - 1,33 \Omega)$
<p><b>OPTION 3/OPSIE 3</b></p> $\mathcal{E} = V_{\text{ext}} + V_{\text{int}}$ $13 = 10,5 + V_{\text{int}}$ $V_{\text{int}} = 2,5 \text{ V}$ $V_{\text{int}} = Ir \checkmark$ $2,5 = (1,88)r \checkmark$ $r = 1,31 \Omega \checkmark (1,31 - 1,33 \Omega)$	

(3)



## 8.4.1 Decreases/Neem af ✓

$V_{\text{internal resistance}}$ /Internal volts increase ✓  
 $V_{\text{interne weerstand}}$ /Interne volts neem toe

(2)

## 8.4.2

**Marking criteria/Nasiensriglyne**

- Formula/Formule  $\mathcal{E} = I(R + r)$  ✓
- Correct substitution into/ Korrekte vervanging in  $\mathcal{E} = I(R + r)$  ✓
- Substitution of values into  $R_p$  formula/Vervanging van waarde van  $R_p$  in formule ✓
- Halving value of  $R_{2X}$ /Halvering van waarde van  $R_{2X}$  ✓
- Final answer/Finale antwoord:  $1,49 \Omega$  ✓ Range/Gebied:  $1,46 \Omega - 1,49 \Omega$

**POSITIVE MARKING FROM QUESTIONS 8.2 AND 8.3.3****POSITIEWE NASIEN VANAF VRAE 8.2 EN 8.3.3****OPTION 1/OPSIE 1**

$$\mathcal{E} = I(R + r) \checkmark$$

$$13 = 4(R_{\text{ext}} + 1,31) \checkmark$$

$$R_{\text{ext}} = 1,94 \Omega \quad (1,92 \Omega)$$

$$\frac{1}{R_p} = \frac{1}{R_1} + \frac{1}{R_2}$$

$$\frac{1}{1,94} = \frac{1}{5,6} + \frac{1}{R_2} \checkmark$$

$$R_2 = 2,97 \Omega \quad (2,92 \Omega)$$

$$X = \frac{1}{2}(2,97) \checkmark$$

$$= 1,49 \Omega \checkmark \quad (1,46 - 1,49 \Omega)$$

**OPTION 2/OPSIE 2**

$$\mathcal{E} = I(R + r) \checkmark$$

$$13 = 4(R_{\text{ext}} + 1,31) \checkmark$$

$$R_{\text{ext}} = 1,94 \Omega \quad (1,92 \Omega)$$

$$R_p = \frac{R_1 R_2}{R_1 + R_2}$$

$$1,94 = \frac{5,6 R_2}{5,6 + R_2} \checkmark$$

$$R_2 = 2,97 \Omega \quad (2,92 \Omega)$$

$$X = \frac{1}{2}(2,97) \checkmark$$

$$= 1,49 \Omega \checkmark \quad (1,46 - 1,49 \Omega)$$

**OPTION 3/OPSIE 3**

$$\mathcal{E} = I(R + r) \checkmark$$

$$13 = 4(R_{\text{ext}} + 1,31) \checkmark$$

$$R_{\text{ext}} = 1,94 \Omega \quad (1,92 \Omega)$$

$$\frac{1}{R_p} = \frac{1}{R_1} + \frac{1}{R_2}$$

$$\left[ \frac{1}{1,94} = \frac{1}{5,6} + \frac{1}{2X} \right] \checkmark$$

$$X = 1,49 \Omega \checkmark \quad (1,46 - 1,49 \Omega)$$

**OPTION 4/OPSIE 4**

$$\mathcal{E} = I(R + r) \checkmark$$

$$13 = 4(R_{\text{ext}} + 1,31) \checkmark$$

$$R_{\text{ext}} = 1,94 \Omega \quad (1,92 \Omega)$$

$$R_p = \frac{R_1 R_2}{R_1 + R_2}$$

$$\left[ 1,94 = \frac{(5,6)(2X)}{5,6 + 2X} \right] \checkmark$$

$$X = 1,49 \Omega \checkmark$$

**OPTION 5/OPSIE 5**

$$\mathcal{E} = I(R + r) \checkmark$$

$$V_{\text{ext}} = 13 - (4)(1,31) \checkmark$$

$$= 7,76 \text{ V}$$

$$V_p = IR_{5,6}$$

$$7,76 = I(5,6)$$

$$I_{5,6\Omega} = 1,37 \text{ A}$$

$$I_T = I_{2X} + I_{5,6}$$

$$4 = I_{2X} + 1,37$$

$$I_{2X} = 2,63 \text{ A}$$

$$V = IR_{2X}$$

$$[7,76 = (2,63)2X] \checkmark$$

$$X = 1,46 \Omega \checkmark$$

**OPTION 6/OPSIE 6**

$$\mathcal{E} = I(R + r) \checkmark$$

$$V_{\text{ext}} = 13 - (4)(1,31) \checkmark$$

$$V_{\text{ext}} = 7,76 \text{ V}$$

$$I_{5,6\Omega} = \frac{7,76}{5,6} = 1,39 \text{ A}$$

$$I_{2X} = 4 - 1,39 = 2,61 \text{ A}$$

$$V_{2X} = I_{2X}R_{2X}$$

$$[7,76 = (2,61)2X] \checkmark$$

$$2X = 2,97 \Omega$$

$$X = 1,49 \Omega \checkmark$$

$$V_X = I_X R_X$$

$$3,88 \checkmark = (2,61)R_X \checkmark$$

$$R_X = 1,49 \Omega \checkmark$$

**OPTION 7/OPSIE 7**

$$\mathcal{E} = I(R + r) \checkmark$$

$$V_{\text{ext}} = 13 - (4)(1,31) \checkmark$$

$$= 7,76 \text{ V}$$

$$V_{\text{ext}} = IR_{\text{ext}}$$

$$7,76 = (4) \left( \frac{1}{2X} + \frac{1}{5,6} \right)^{-1} \checkmark$$

$$X = 1,48 \Omega \checkmark$$

(5)  
[19]**QUESTION 9/VRAAG 9**

9.1

9.1.1 DC/GS ✓

(1)

9.1.2

**NOTE:** -1 mark for each key word/phrase omitted in correct context.**LET WEL:** -1 punt vir elke sleutel woord/frase weggelaat in die korrekte konteks.Emf is induced as a result of change of magnetic flux (linked) with the coil. ✓✓Emk word geïnduseer as gevolg van verandering van die magnetiese vloedkoppeling.

(2)

9.1.3

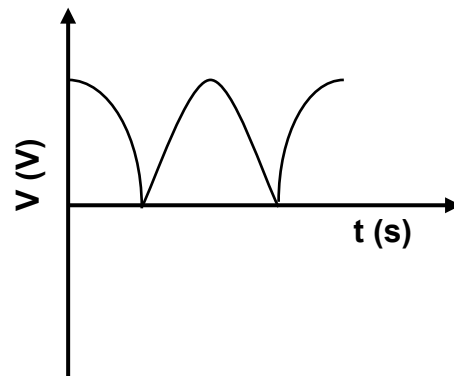
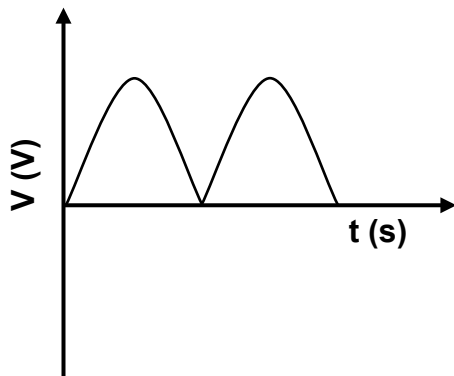
**POSITIVE MARKING FROM QUESTION 9.1.1****POSITIEWE NASIEN VANAF VRAAG 9.1.1**

OR/OF

**Marking criteria for graph:**

Correct shape <i>Korrekte vorm</i>	✓
One complete cycle/ <i>Een volledige siklus</i>	✓

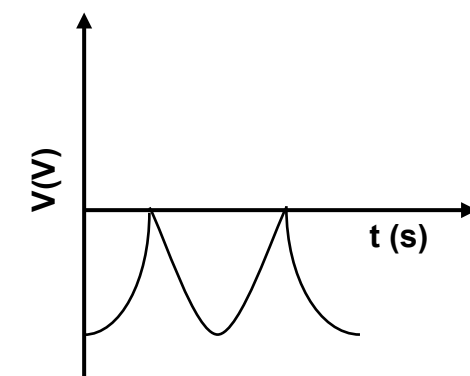
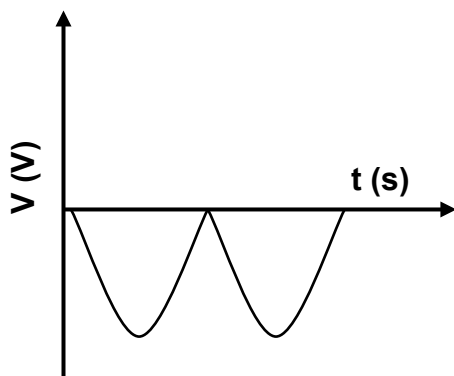

(2)

9.2.1 The AC potential difference/voltage which dissipates the same amount of energy ✓ as DC potential difference. ✓

*Die WS potensiaalverskil/spanning wat dieselfde hoeveelheid energie verbruik as GS potensiaalverskil/spanning*

**OR/OF**

(The rms value of AC is) the DC potential difference/voltage which dissipates the same amount of energy ✓ as AC potential difference/voltage. ✓

*Dit is die GS potensiaalverskil/spanning wat dieselfde hoeveelheid energie verbruik as WS potensiaalverskil/spanning*

(2)

9.2.2

<p><b>OPTION 1 / OPSIE 1</b></p> $W = \frac{V^2}{R} \Delta t \checkmark$ $500 = \frac{V^2}{200} (10) \checkmark$ $V = V_{\text{rms}} = 100 \text{ V}$ $V_{\text{rms}} = \frac{V_{\text{max}}}{\sqrt{2}} \checkmark$ $100 = \frac{V_{\text{max}}}{\sqrt{2}} \checkmark$ $V_{\text{max}} = 141,42 \text{ V} \checkmark$	<p><b>OPTION 2 / OPSIE 2</b></p> $W = I^2 R \Delta t$ $500 = I^2 (200)(10)$ $I = I_{\text{rms}} = 0,5 \text{ A}$ $P_{\text{ave}} = V_{\text{rms}} I_{\text{rms}} \checkmark$ $\frac{500}{10} = V_{\text{rms}} (0,5) \checkmark$ $V_{\text{rms}} = 100 \text{ V}$ $V_{\text{rms}} = \frac{V_{\text{max}}}{\sqrt{2}} \checkmark$ $100 = \frac{V_{\text{max}}}{\sqrt{2}} \checkmark$ $V_{\text{max}} = 141,42 \text{ V} \checkmark$	<p><b>OPTION 3 / OPSIE 3</b></p> $P_{\text{ave}} = I_{\text{rms}}^2 R$ $\frac{500}{10} = I_{\text{rms}}^2 (200)$ $I_{\text{rms}} = 0,5 \text{ A}$ $P_{\text{ave}} = V_{\text{rms}} I_{\text{rms}} \checkmark$ $\frac{500}{10} = V_{\text{rms}} (0,5) \checkmark$ $V_{\text{rms}} = 100 \text{ V}$ $V_{\text{rms}} = \frac{V_{\text{max}}}{\sqrt{2}} \checkmark$ $100 = \frac{V_{\text{max}}}{\sqrt{2}} \checkmark$ $V_{\text{max}} = 141,42 \text{ V} \checkmark$	<p><b>OPTION 4 / OPSIE 4</b></p> $R = \frac{V_{\text{rms}}}{I_{\text{rms}}} \checkmark$ $200 = \frac{V_{\text{rms}}}{0,5} \checkmark$ $V_{\text{rms}} = 100 \text{ V}$ $V_{\text{rms}} = \frac{V_{\text{max}}}{\sqrt{2}} \checkmark$ $100 = \frac{V_{\text{max}}}{\sqrt{2}} \checkmark$ $V_{\text{max}} = 141,42 \text{ V} \checkmark$
<p><b>OPTION 5 / OPSIE 5</b></p> $P_{\text{ave}} = \frac{V_{\text{rms}}^2}{R} \checkmark$ $\frac{500}{10} = \frac{V_{\text{rms}}^2}{200} \checkmark$ $V_{\text{rms}} = 100 \text{ V}$ $V_{\text{rms}} = \frac{V_{\text{max}}}{\sqrt{2}} \checkmark$ $100 = \frac{V_{\text{max}}}{\sqrt{2}} \checkmark$ $V_{\text{max}} = 141,42 \text{ V} \checkmark$	<p><b>OPTION 6 / OPSIE 6</b></p> $P_{\text{ave}} = \frac{P_{\text{max}}}{2} \checkmark$ $\frac{500}{10} = \frac{P_{\text{max}}}{2} \checkmark$ $P_{\text{max}} = 100 \text{ W}$ $P_{\text{max}} = \frac{V_{\text{max}}^2}{R} \checkmark$ $100 = \frac{V_{\text{max}}^2}{200} \checkmark$ $V_{\text{max}} = 141,42 \text{ V} \checkmark$	<p><b>OPTION 7 / OPSIE 7</b></p> $P = \frac{W}{\Delta t} = \frac{500}{10}$ $= 50 \text{ W}$ $P_{\text{ave}} = \frac{V_{\text{rms}}^2}{R} \checkmark$ $50 = \frac{V_{\text{rms}}^2}{200} \checkmark$ $V_{\text{rms}} = 100 \text{ V}$ $V_{\text{rms}} = \frac{V_{\text{max}}}{\sqrt{2}} \checkmark$ $100 = \frac{V_{\text{max}}}{\sqrt{2}} \checkmark$ $V_{\text{max}} = 141,42 \text{ V} \checkmark$	<p><b>OPTION 8 / OPSIE 8</b></p> $P_{\text{ave}} = I_{\text{rms}}^2 R \checkmark$ $\frac{500}{10} = I_{\text{rms}}^2 (200) \checkmark$ $I_{\text{rms}} = 0,5 \text{ A}$ $I_{\text{rms}} = \frac{I_{\text{max}}}{\sqrt{2}} \checkmark$ $0,5 = \frac{I_{\text{max}}}{\sqrt{2}} \checkmark$ $I_{\text{max}} = 0,71 \text{ A}$ $V_{\text{max}} = I_{\text{max}} R \checkmark$ $= (0,71)(200) \checkmark$ $= 142 \text{ V} \checkmark$

(5)  
[12]

**QUESTION 10/VRAAG 10**

10.1

**Note:** -1 mark for each key word/phrase omitted in correct context.**Let Wel:** -1 punt vir elke sleutel woord/frase weggelaat in die korrekte konteks.

The process whereby electrons are ejected from a metal / surface when light (of suitable frequency) is incident on that surface. ✓✓

Die proses waarby elektrone vanaf 'n (metaal)oppervlak vrygestel word wanneer lig (van geskikte frekwensie) daarop skyn/inval.

(2)

10.2

7,48 x 10<sup>-19</sup> (J) ✓ $E = W_o + E_{k(max)} (= W_o + \frac{1}{2}mv_{max}^2)$  ✓

When/Wanneer  $E_{k(max)} = 0$  /  $v = 0$  /  $v^2 = 0$  /  $E = W_o$  /  $W_o$  is the y-intercept / is die y-afsnit ✓

(3)

10.3

Mass (of photo-electron)/Massa (van foto-elektron)/m ✓

**ACCEPT/AANVAAR:** $\frac{1}{2}m$ 

(1)

10.4

**OPTION 1/OPSIE 1**Gradient =  $\frac{1}{2}m$ 

$$\frac{11,98 \times 10^{-19} - 7,48 \times 10^{-19}}{X - 0} = \frac{1}{2}(9,11 \times 10^{-31}) \quad \checkmark$$

$$X = 0,9879 \quad \checkmark \quad (0,99 \text{ or } 0,988)$$

**ACCEPT/AANVAAR**

$$X = 0,9879 \times 10^{12} \text{ (m}^2 \cdot \text{s}^{-2}\text{)}$$

**POSITIVE MARKING FROM 10.2/POSITIEWE NASIEN VANAF 10.2****OPTION 2/ OPSIE 2**

$$E = W_o + E_{k(max)} \quad \left. \vphantom{E = W_o + E_{k(max)}} \right\} \quad \checkmark \text{ Any one / Enige een}$$

$$E = W_o + \frac{1}{2}mv_{(max)}^2$$

$$11,98 \times 10^{-19} \quad \checkmark = 7,48 \times 10^{-19} \quad \checkmark + \frac{1}{2}(9,11 \times 10^{-31}) v^2 \quad \checkmark \quad [\text{or/of } \frac{1}{2}(9,11 \times 10^{-31})X]$$

$$4,5 \times 10^{-19} = 4,56 \times 10^{-31} v^2$$

$$v^2 = 0,9868 \times 10^{12}$$

$$X/v^2 = 0,9868 \quad \checkmark \quad (0,99)$$

$$\text{Range/gebied } (0,9868 - 0,9879 / 9,87 \times 10^{11} - 9,88 \times 10^{11})$$

**ACCEPT/AANVAAR:**

$$X = 0,9868 \times 10^{12} \text{ (m}^2 \cdot \text{s}^{-2}\text{)} / 9,868 \times 10^{11} \text{ (m}^2 \cdot \text{s}^{-2}\text{)}$$

(5)

10.5.1

Remains the same / Bly dieselfde ✓

(1)

10.5.2

Increases / Neem toe ✓

(1)

**[13]****TOTAL/TOTAAL:****150**