



basic education

Department:
Basic Education
REPUBLIC OF SOUTH AFRICA

**NATIONAL
SENIOR CERTIFICATE**

GRADE 10

PHYSICAL SCIENCES: PHYSICS (P1)

NOVEMBER 2018

MARKS: 150

TIME: 2 hours

This question paper consists of 17 pages, 2 data sheets and 1 answer sheet.

INSTRUCTIONS AND INFORMATION

1. Write your name and class (e.g. 10A) in the appropriate spaces on the ANSWER BOOK.
2. This question paper consists of 11 questions. Answer ALL the questions in the ANSWER BOOK.
3. Hand in the ANSWER SHEET with the ANSWER BOOK.
4. Start EACH question on a NEW page in the ANSWER BOOK.
5. Number the answers correctly according to the numbering system used in this question paper.
6. Leave ONE line between two subquestions, e.g. between QUESTION 2.1 and QUESTION 2.2.
7. You may use a non-programmable calculator.
8. You may use appropriate mathematical instruments.
9. You are advised to use the attached DATA SHEETS.
10. Show ALL formulae and substitutions in ALL calculations.
11. Round off your final numerical answers to a minimum of TWO decimal places.
12. Give brief motivations, discussions, etc. where required.
13. Write neatly and legibly.

QUESTION 1: MULTIPLE-CHOICE QUESTIONS

Various options are provided as possible answers to the following questions. Each question has only ONE correct answer. Choose the answer and write only the letter (A–D) next to the question numbers (1.1 to 1.10) in the ANSWER BOOK, e.g. 1.11 D.

- 1.1 An object is positively charged if it has more ...
- A electrons than protons.
 - B electrons than neutrons.
 - C protons than electrons.
 - D protons than neutrons. (2)
- 1.2 A car is travelling at a speed of $30 \text{ m}\cdot\text{s}^{-1}$ on a straight road. What would be the speed of the car in $\text{km}\cdot\text{h}^{-1}$?
- A $8,33 \text{ km}\cdot\text{h}^{-1}$
 - B $30 \text{ km}\cdot\text{h}^{-1}$
 - C $108 \text{ km}\cdot\text{h}^{-1}$
 - D $130 \text{ km}\cdot\text{h}^{-1}$ (2)
- 1.3 The UNIT in which the rate of flow of charge is measured, is called ...
- A ampere.
 - B coulomb.
 - C volt.
 - D watt. (2)
- 1.4 The gradient of a velocity versus time graph is equivalent to the ...
- A acceleration.
 - B displacement.
 - C position.
 - D total distance covered. (2)

- 1.5 An object is released from the top of a frictionless inclined plane, **AB**, as shown below.

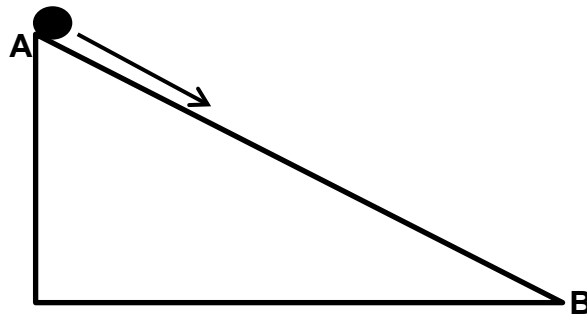

Which ONE of the following statements regarding the total mechanical energy of the object is CORRECT?

- A $(E_p + E_k)_A > (E_p + E_k)_B$
- B $(E_p + E_k)_A < (E_p + E_k)_B$
- C $(E_p + E_k)_A = (E_p + E_k)_B$
- D $(E_p + E_k)_A = - (E_p + E_k)_B$ (2)

- 1.6 Two identical light bulbs are connected in parallel, as shown in the circuit diagram below. Voltmeters V_1 and V_2 are connected across each light bulb.

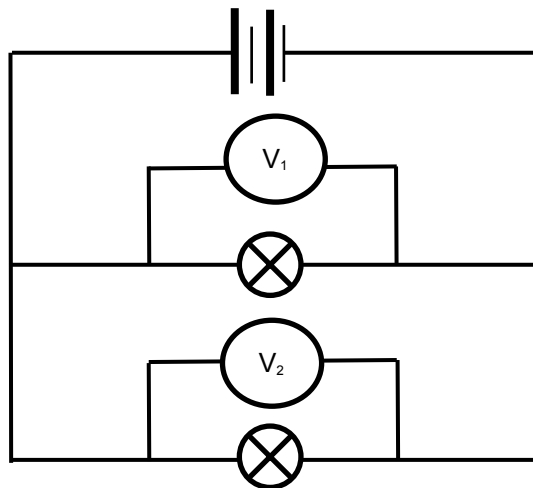

Which ONE of the following voltmeter readings is CORRECT?

- A $V_1 = V_2$
- B $V_1 = 2V_2$
- C $V_1 = \frac{1}{2}V_2$
- D $V_1 = \frac{1}{4}V_2$ (2)

- 1.7 Four identical balloons, each carrying a charge, are suspended from a ceiling, as shown in the diagram below.

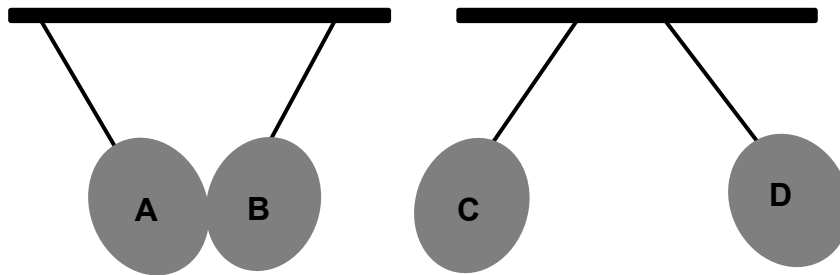

Balloon **B** is negatively charged.

Which combination is CORRECT regarding the charges on the balloons?

	SIGN OF CHARGE ON A	SIGN OF CHARGE ON C	SIGN OF CHARGE ON D
A	-	+	-
B	+	+	+
C	-	-	-
D	+	+	-

(2)

- 1.8 Two cyclists are cycling in opposite directions along the side line of a rectangular field. It is observed that they covered the same distance over a time interval of 3 s. Which ONE of the following physical quantities is the SAME regarding the cyclists over the interval of 3 s?

- A Acceleration
 - B Average speed
 - C Average velocity
 - D Displacement
- (2)

- 1.9 Red light of frequency f and wavelength λ shines on an object. The red light is then replaced by light of a higher energy. How do the frequency and the wavelength of light shining on the object now compare with that of red light?

	FREQUENCY	WAVELENGTH
A	Greater than f	Remains the same (λ)
B	Less than f	Greater than λ
C	Greater than f	Less than λ
D	Remains the same (f)	Less than λ

(2)

1.10 Study the following wave patterns:

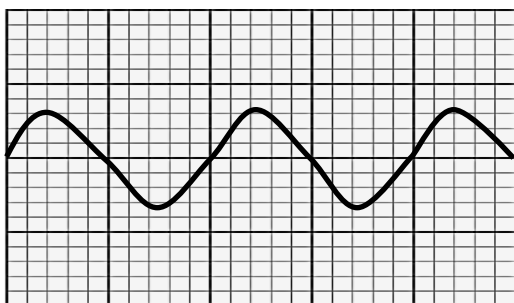

1

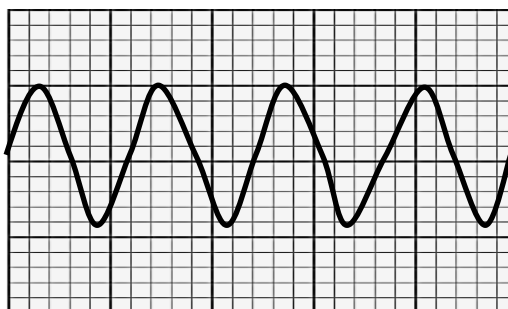

2

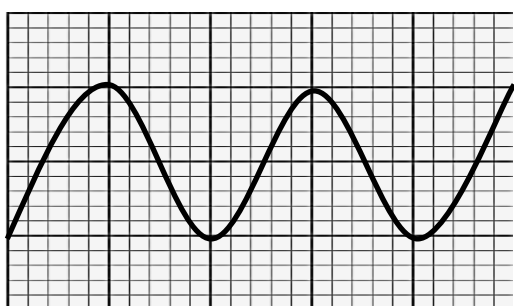

3

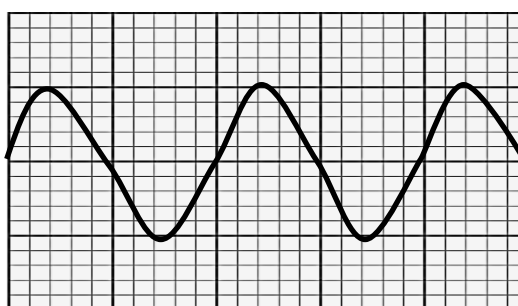

4

Which COMBINATION is the CORRECT representation of the wave patterns with the same pitch?

- A 1 and 2
- B 1 and 3
- C 1 and 4
- D 2 and 4

(2)
[20]

QUESTION 2 (Start on a new page.)

A baby leaves a bowl of food on the floor and crawls westwards to fetch a toy placed 5 m away. At the same time a dog walks eastwards towards the baby. It takes the baby 30 s to reach the toy. The dog walks past the toy to eat the baby's food in the bowl.

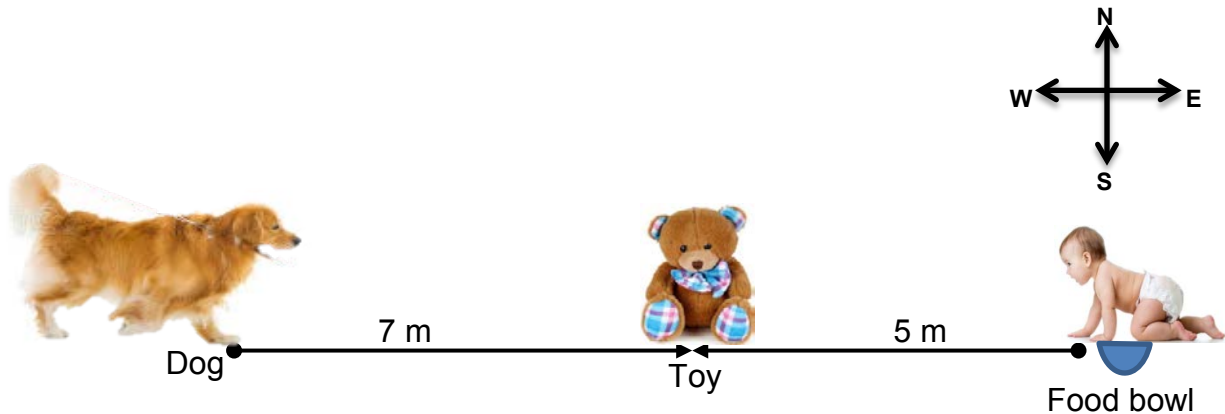

- 2.1 Define the term *displacement* in words. (2)
- 2.2 Determine the position of the dog relative to the baby before they both moved. (2)
- 2.3 Calculate the average velocity of the baby. (4)
- 2.4 If the average speed of the dog is TWICE that of the baby, calculate how long it would take the dog to reach the food bowl from the moment the dog started moving. (4)
- [12]**

QUESTION 3 (Start on a new page.)

The diagram below shows the positions of an athlete at different time intervals during a race.

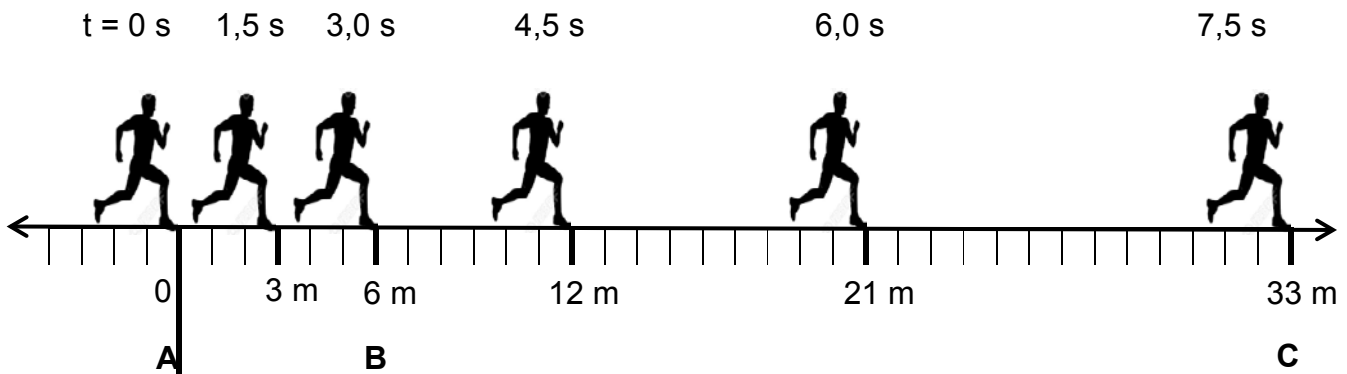

- 3.1 Distinguish between *motion with uniform velocity* and *uniformly accelerated motion*. (4)
- 3.2 What type of motion (motion with uniform velocity or uniformly accelerated motion) is represented by the following intervals?
- 3.2.1 **A to B** (1)
- 3.2.2 **B to C** (1)
- 3.3 Use the information in the diagram above to draw an accurate position versus time graph on the graph paper on the attached ANSWER SHEET. (5)
- 3.4 Define the term *instantaneous velocity* in words. (2)
- 3.5 On the graph drawn for QUESTION 3.3, show how you would determine the instantaneous velocity. (2)
- 3.6 Calculate the velocity of the athlete at 3 s. (4)

[19]

QUESTION 4 (Start on a new page.)

Two cars, **A** and **B**, are moving at speeds of $15 \text{ m}\cdot\text{s}^{-1}$ and $30 \text{ m}\cdot\text{s}^{-1}$ in the same direction. They are side by side when both drivers observe an obstruction ahead of them, as shown in the diagram below.

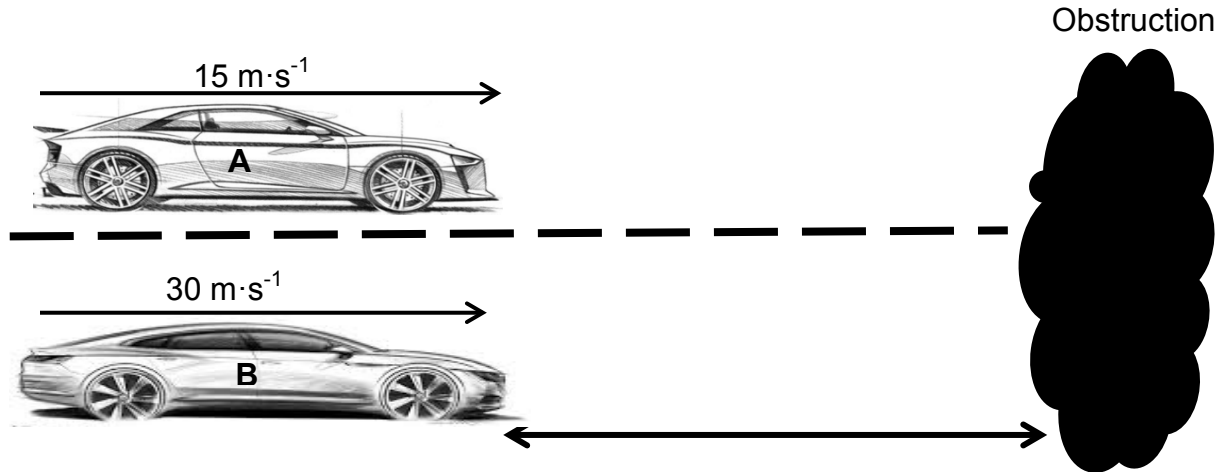

Both drivers apply their brakes and accelerate at $-4,5 \text{ m}\cdot\text{s}^{-2}$ until both cars come to rest. Ignore the reaction time of the drivers.

- 4.1 Define the term *acceleration* in words. (2)
- 4.2 Calculate the:
- 4.2.1 Time it takes car **A** to come to rest (4)
- 4.2.2 Stopping distance of car **A** (4)
- 4.3 Which car (**A** or **B**) has the longer stopping distance? Support the answer with a calculation. (6)
- 4.4 What conclusion can be made about the relationship between speed and stopping distance? (2)
- [18]**

QUESTION 5 (Start on a new page.)

A skateboarder, starting from the top of a ramp 4,5 m above the ground, skates down the ramp, as shown in the diagram below. The mass of the skateboarder and his board is 65 kg. Ignore the effects of friction.

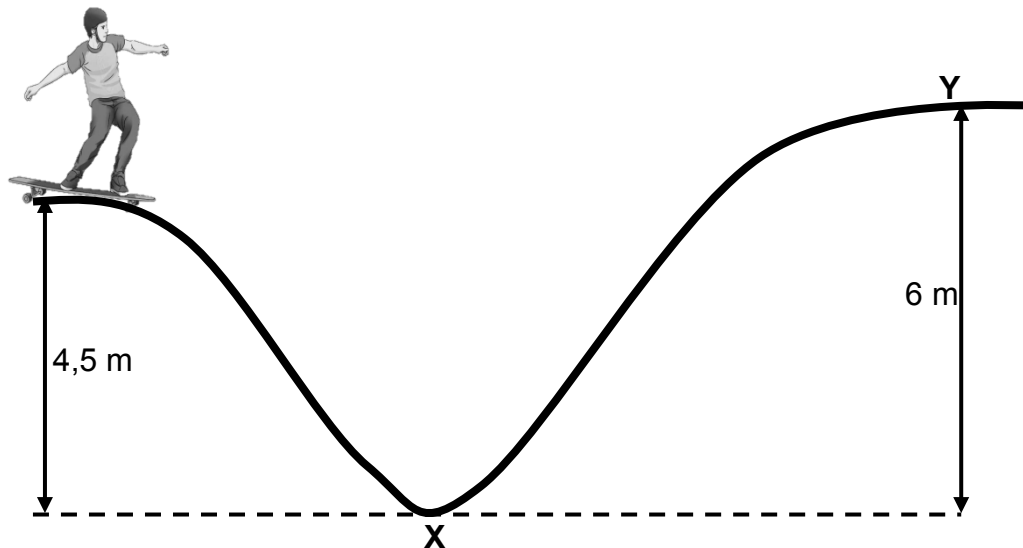

- 5.1 Define the term *gravitational potential energy* in words. (2)
- 5.2 Calculate the gravitational potential energy of the skater just before he skates down the ramp. (3)
- 5.3 State the *principle of conservation of mechanical energy* in words. (2)
- 5.4 Use the principle stated in QUESTION 5.3 to calculate the magnitude of the velocity of the skateboarder when he reaches the ground at point X. (4)
- 5.5 Will the skateboarder be able to reach point Y if he were to remain on his skateboard? Write YES or NO and support the answer with a relevant calculation. (5)

[16]

QUESTION 6 (Start on a new page.)

Study the two transverse waves, **P** and **Q**, as shown below.

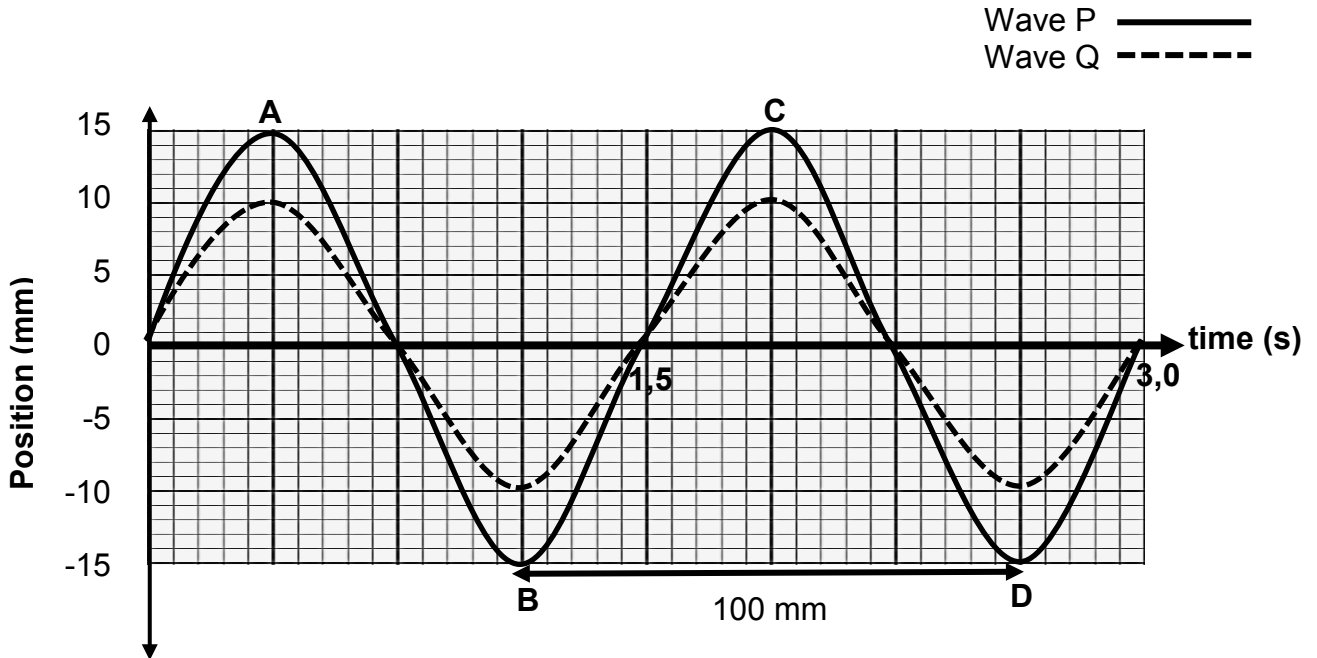

- 6.1 Write down ONE difference and ONE similarity between wave **P** and wave **Q**. (2)
- 6.2 For wave pattern **P**, write down:
- 6.2.1 Two points that are out of phase (1)
- 6.2.2 The amplitude of the wave (1)
- 6.3 Define the term *frequency of the wave* in words. (2)
- 6.4 For wave pattern **Q**, calculate the:
- 6.4.1 Frequency of the wave (3)
- 6.4.2 Speed of the wave (3)
- [12]**

QUESTION 7 (Start on a new page.)

Experiments were done to investigate the effect of temperature on the speed of sound. One person beat a drum while another person, who was standing 50 m away from the sound source, recorded the time travelled by the sound.

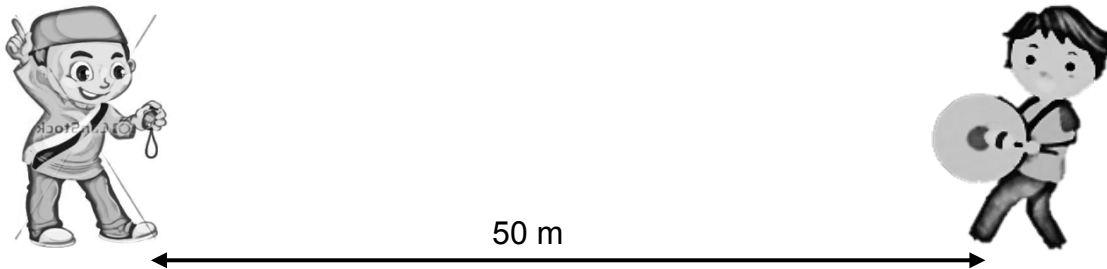

They performed the experiment at different temperatures at different times of the day. They recorded their findings in the table below.

TEMPERATURE (°C)	TIME (s)
0	0,151
5	0,150
10	0,148
15	0,147
20	0,146
25	0,145

- 7.1 For the investigation, write down the:
- 7.1.1 Investigative question (2)
- 7.1.2 Independent variable (1)
- 7.1.3 Dependent variable (1)
- 7.2 Calculate the speed of sound at 20 °C. (3)
- 7.3 Write down a conclusion for the investigation. (2)
- The person who beat the drum, noticed that the sound reflected back after a while.
- 7.4 Name the term used to describe the reflection of sound waves. (1)

[10]

QUESTION 8 (Start on a new page.)

The types of electromagnetic radiation are arranged according to frequency in the table below.

TYPE OF RADIATION	FREQUENCY (Hz)
Radio waves	$10^5 - 10^{10}$
Microwaves	$10^{10} - 10^{11}$
Infrared	$10^{11} - 10^{14}$
Visible light	$10^{14} - 10^{15}$
Ultraviolet	$10^{15} - 10^{16}$
X-rays	$10^{16} - 10^{18}$
Gamma rays	$10^{18} - 10^{21}$

- 8.1 How are electromagnetic waves generated? (1)
- 8.2 What type of electromagnetic radiation has the highest energy? (1)
- 8.3 Explain the answer to QUESTION 8.2. (2)
- 8.4 A certain type of electromagnetic radiation has a wavelength of 600×10^{-10} m.
- 8.4.1 Identify the type of electromagnetic radiation by performing a calculation. (4)
- 8.4.2 State ONE application of the type of radiation identified in QUESTION 8.4.1. (1)
- [9]**

QUESTION 9 (Start on a new page.)

Four metallic bars, suspended freely from a ceiling, interact, as shown in the diagram below. The points of attachment of **X** and **Y** on the ceiling are 4 cm apart.

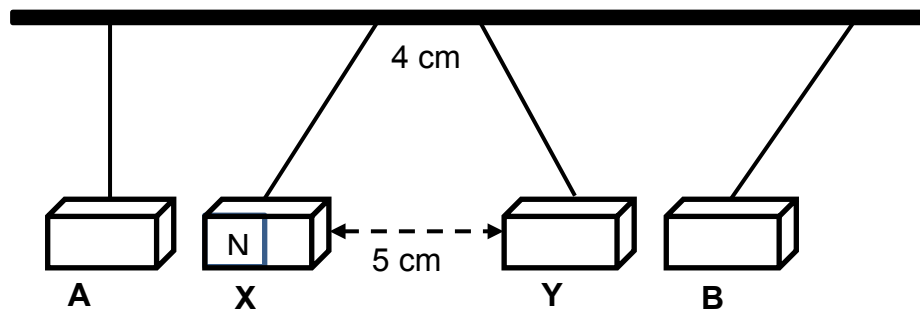

The two bars in the middle are **bar magnets** (**X** and **Y**) and the distance between them is 5 cm. One of the bars (**A** or **B**) is made of iron and the other is made of gold.

- 9.1 Write down the term describing a material that is easily magnetised. (1)
- 9.2 Which ONE of the bars (**A** or **B**) is made of iron? (1)
- 9.3 Determine the polarity of bar **B** closest to bar magnet **Y**. Write only NORTH or SOUTH. (1)
- 9.4 Explain the answer to QUESTION 9.3. (2)
- 9.5 Sketch the magnetic field pattern around bar magnet **X**. (3)
- 9.6 Bars **A** and **B** are now removed and the points of attachment are now 2 cm, as shown in the diagram below.

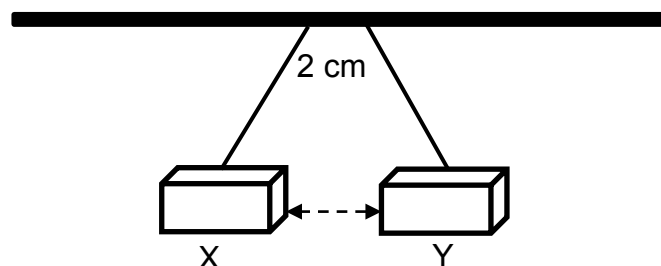

- 9.6.1 How will the change in the position of the attachment affect the final distance of separation between the bars? Write only GREATER THAN 5 cm, LESS THAN 5 cm or REMAINS at 5 cm. (1)
- 9.6.2 Explain the answer to QUESTION 9.6.1. (2)

[11]

QUESTION 10 (Start on a new page.)

Two identical insulated spheres, **X** and **Y**, suspended by threads from a ceiling, are held at a small distance apart, as shown in the diagram below.

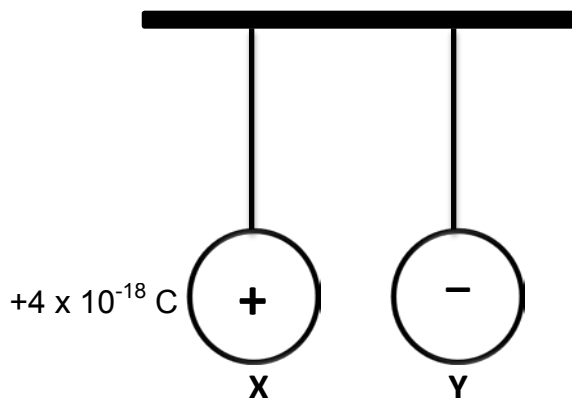

Sphere **X** carries a charge of $+ 4 \times 10^{-18}$ C, while sphere **Y** has an excess of 30 electrons.

10.1 Calculate the magnitude of the charge on sphere **Y**. (3)

The spheres are now released and they move towards each other.

10.2 Give a reason why spheres **X** and **Y** move towards each other. (2)

The spheres are allowed to touch each other. After touching, they move away from each other.

10.3 State the *principle of conservation of charge* in words. (2)

10.4 Calculate the charge on each sphere after they have separated. (4)

[11]

QUESTION 11 (Start on a new page.)

11.1 Consider the circuit diagram below.

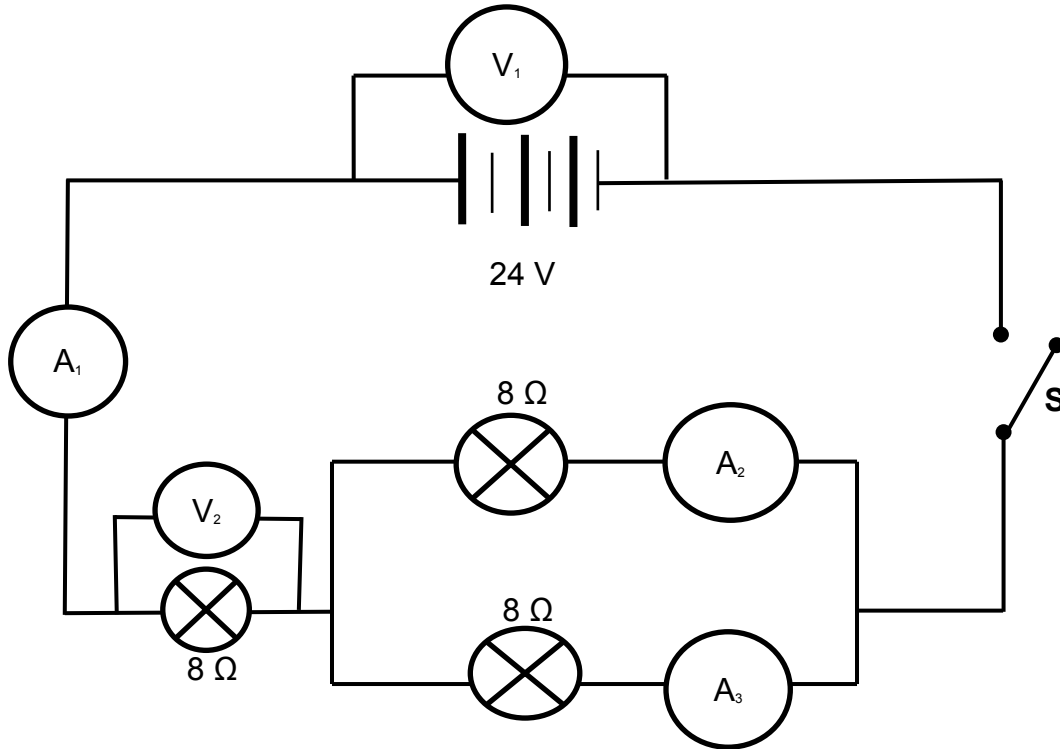
Switch **S** is OPEN.

11.1.1 Write down the reading on the following:

- (a) Voltmeter (V_1) (1)
- (b) Ammeter (A_1) (1)

Switch **S** is now CLOSED.

- 11.1.2 Calculate the equivalent resistance of the circuit. (4)
- 11.1.3 Calculate the reading on voltmeter V_2 . (3)
- 11.1.4 How do the readings on ammeters A_2 and A_3 compare with each other? (1)

- 11.2 The graph below shows the relationship between the resistance and the length of the conducting wire.

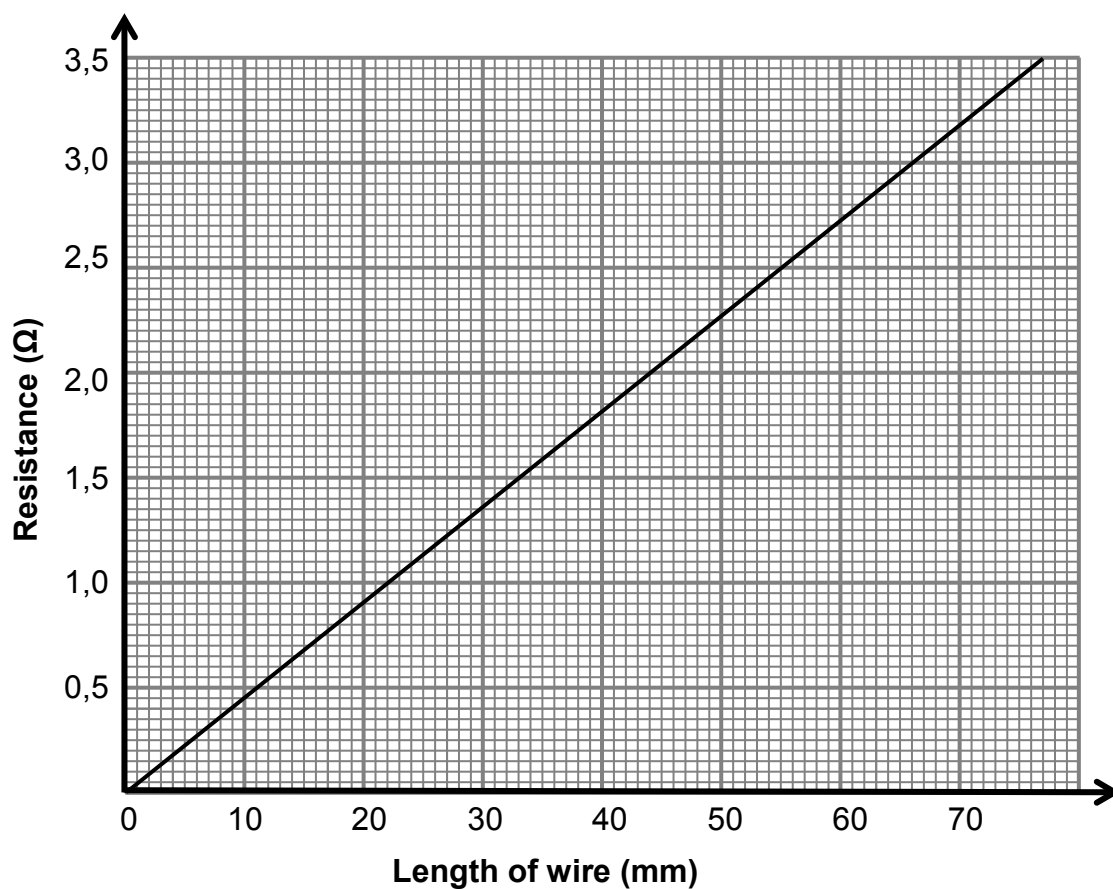

- 11.2.1 Write down the relationship between the resistance and the length of the conducting wire. (1)

- 11.2.2 Determine the resistance of wire with a length of 30 mm. (1)

[12]

TOTAL: 150

**DATA FOR PHYSICAL SCIENCES GRADE 10
PAPER 1 (PHYSICS)
GEGEWENS VIR FISIESTE WETENSAPPE GRAAD 10
VRAESTEL 1 (FISIKA)**

TABLE 1: PHYSICAL CONSTANTS/TABEL 1: FISIESTE KONSTANTES

NAME/NAAM	SYMBOL/SIMBOOL	VALUE/WAARDE
Acceleration due to gravity <i>Swaartekragversnelling</i>	g	9,8 m·s ⁻²
Speed of light in a vacuum <i>Spoed van lig in 'n vakuum</i>	c	3,0 x 10 ⁸ m·s ⁻¹
Planck's constant <i>Planck se konstante</i>	h	6,63 x 10 ⁻³⁴ J·s
Charge on electron <i>Lading op elektron</i>	e	-1,6 x 10 ⁻¹⁹ C
Electron mass <i>Elektronmassa</i>	m _e	9,11 x 10 ⁻³¹ kg

TABLE 2: FORMULAE/TABEL 2: FORMULES**MOTION/BEWEGING**

$v_f = v_i + a\Delta t$	$\Delta x = v_i\Delta t + \frac{1}{2}a\Delta t^2$
$v_f^2 = v_i^2 + 2a\Delta x$	$\Delta x = \left(\frac{v_f + v_i}{2}\right)\Delta t$

WORK, ENERGY AND POWER/ARBEID, ENERGIE EN DRYWING

$U = mgh$ or/of $E_p = mgh$	$K = \frac{1}{2}mv^2$ or/of $E_k = \frac{1}{2}mv^2$
$E_M = E_k + E_p$ or/of $E_M = K + U$	

WAVES, SOUND AND LIGHT/GOLWE, KLANK EN LIG

$v = f\lambda$	$T = \frac{1}{f}$
$E = hf$ or/of $E = h\frac{c}{\lambda}$	

ELECTROSTATICS/ELEKTROSTATIKA

$n = \frac{Q}{e}$	$Q = \frac{Q_1 + Q_2}{2}$
-------------------	---------------------------

ELECTRIC CIRCUITS/ELEKTRIESE STROOMBANE

$Q = I \Delta t$	$\frac{1}{R_p} = \frac{1}{R_1} + \frac{1}{R_2} + \dots$
$R_s = R_1 + R_2 + \dots$	$V = \frac{W}{q}$

ANSWER SHEET

Hand in this ANSWER SHEET with the ANSWER BOOK.

NAME: _____

CLASS: _____

QUESTION 3.3

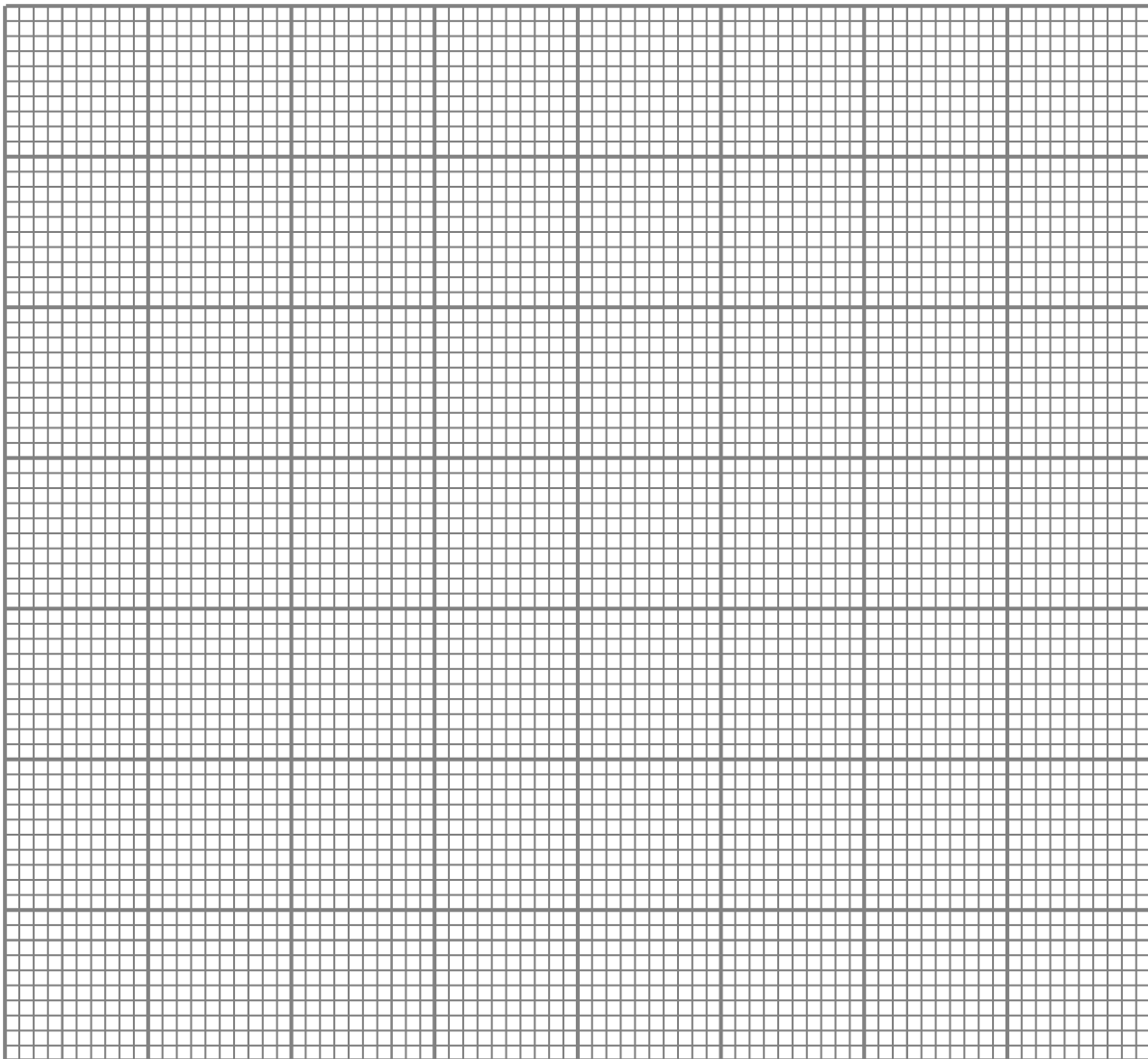



basic education

Department:
Basic Education
REPUBLIC OF SOUTH AFRICA

**NATIONAL
SENIOR CERTIFICATE/
NASIONALE
SENIOR SERTIFIKAAT**

GRADE/GRAAD 10

**PHYSICAL SCIENCES: PHYSICS (P1)
FISIESE WETENSKAPPE: FISIKA (V1)**

NOVEMBER 2018

MARKING GUIDELINES/NASIENRIGLYNE

MARKS/PUNTE: 150

**These marking guidelines consist of 12 pages.
Hierdie nasienriglyne bestaan uit 12 bladsye.**

QUESTION 1/VRAAG 1

- 1.1 C✓✓
- 1.2 C✓✓
- 1.3 A✓✓
- 1.4 A✓✓
- 1.5 C✓✓
- 1.6 A✓✓
- 1.7 B✓✓
- 1.8 B✓✓
- 1.9 C✓✓
- 1.10 C/B✓✓

[20]

QUESTION 2/VRAAG 2

- 2.1 The difference in position (in space). ✓✓/Die verskil in posisie in ruimte.

OR/OF

The change in position (of an object.)✓✓/Die verandering in posisie van 'n voorwerp. (2)

- 2.2 12 m ✓west/wes✓ or/of -12 m ✓✓

IF/INDIEN

- 12 m West/Wes (Award 1 mark only/Ken 1 punt toe)

Accept/Aanvaar

12 m✓ left/links ✓ (2)

- 2.3
$$v = \frac{\Delta x}{\Delta t}$$
$$= \frac{5}{30} \checkmark$$
$$= 0,17 \text{ m}\cdot\text{s}^{-1} \checkmark \text{ west/wes } \checkmark$$

Accept/Aanvaar

0,17 m·s⁻¹✓ left/links ✓ (4)

2.4 **POSITIVE MARKING FROM 2.2 and 2.3/POSITIEWE NASIEN VANAF 2.2.en2.3**

$$\text{Speed} = \frac{\text{distance}}{\text{time}} / \text{Spoed} = \frac{\text{afstand}}{\text{tyd}}$$

$$(0,17)(2) \checkmark = 0,34 \text{ m}\cdot\text{s}^{-1}$$

$$0,34 \checkmark = \frac{12 \checkmark}{\Delta t}$$

$$\Delta t = 35,29 \text{ s} \checkmark$$

(4)
[12]

QUESTION 3/VRAAG 3

3.1 **Motion with uniform velocity:** Motion at constant velocity. ✓✓/ Motion with zero or no acceleration.

Beweging met uniforme snelheid: *Beweging teen konstante snelheid./ Beweging met nul of geen versnelling.*

Uniform accelerated motion: Motion with constant acceleration. ✓✓/ Velocity changes with the same amount during each time interval. ✓✓/ Motion during which the velocity changes with a constant amount per unit time. ✓✓/

Uniforme versnelde beweging: *Beweging met konstante versnelling/Snelheid verander met dieselfde hoeveelheid gedurende elke tydinterval/Beweging waartydens die snelheid met 'n konstante hoeveelheid per eenheid tyd verander.*

(4)

3.2.1 Motion with uniform velocity ✓/ *Beweging met uniforme snelheid*

(1)

3.2.2 Uniform accelerated motion ✓/ *Uniforme versnelde beweging*

(1)

3.3

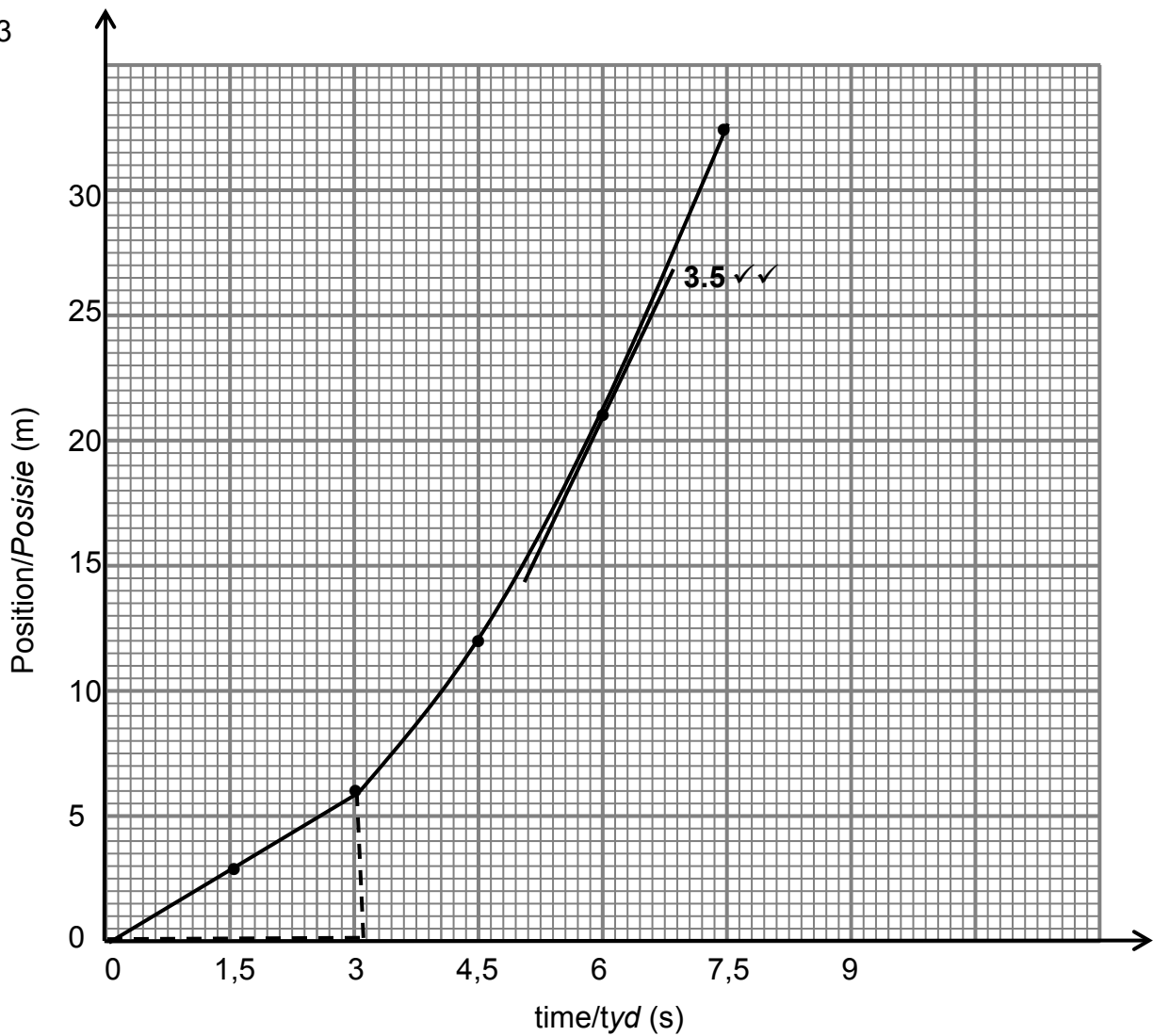

MARKING GUIDELINES/NASIENRIGLYNE

- ✓ x-axis and units correctly labelled/x-as en eenhede korrek gemerk
- ✓ y-axis and units correctly labelled/y-as en eenhede korrek gemerk
- ✓ 2 points correctly plotted and joined/2 punte korrek gestip en verbind
- ✓ shape of the graph (0 – 3 s/vorm van die grafiek(0 – 3s) / straight line/reguitlyn
- ✓ shape of graph 3 – 7,5 s curved / vorm van grafiek 3 – 7,5 s kurwe / tangent /raaklyn

(5)

- 3.4 Instantaneous velocity: rate of change in position. ✓✓/Oombliklike snelheid: tempo van verandering in posisie.

OR/OF

Displacement divided by a very small time interval. ✓✓/Verplasing gedeel deur 'n baie klein tydinterval.

OR/OF

Velocity at a particular time. ✓✓/Snelheid op 'n spesifieke tyd.

(2)

- 3.5 Refer to the graph./Verwys na die grafiek.
(Tangent to the curve/ Raaklyn aan kurwe)

(2)

3.6
$$v = \frac{\Delta x}{\Delta t}$$
$$= \frac{6-0}{3-0} \checkmark$$
$$= 2 \text{ m}\cdot\text{s}^{-1} \checkmark \quad \text{right/regs } \checkmark$$

(4)

[19]

QUESTION 4/VRAAG 4

- 4.1 The rate of change of velocity. ✓✓/Die tempo van verandering van snelheid.

(2)

4.2.1
$$v_f = v_i + a\Delta t \checkmark$$
$$0 \checkmark = 15 + (-4,5)\Delta t \checkmark$$
$$\Delta t = 3,33 \text{ s } \checkmark$$

OR/OF

$$v_f = v_i + a\Delta t \checkmark$$
$$0 \checkmark = -15 + (4,5)\Delta t \checkmark$$
$$\Delta t = 3,33 \text{ s } \checkmark$$

(4)

- 4.2.2

OPTION 1/OPSIE 1

$$v_f^2 = v_i^2 + 2a\Delta x \checkmark$$
$$0^2 \checkmark = 15^2 + 2(-4,5)\Delta x \checkmark$$
$$\Delta x = 25 \text{ m } \checkmark$$

OPTION 2/OPSIE 2

POSITIVE MARKING FROM 4.2.1/POSITIEWE NASIEN VANAF 4.2.1

$$\Delta x = \left(\frac{v_f + v_i}{2} \right) \Delta t \checkmark$$
$$= \left(\frac{0 + 15}{2} \right) (3,33) \checkmark$$
$$= 24,98 \text{ m } \checkmark$$

OPTION 3/OPSIE 3

POSITIVE MARKING FROM 4.2.1/POSITIEWE NASIEN VANAF 4.2.1

$$\Delta x = v_i\Delta t + \frac{1}{2} a\Delta t^2 \checkmark$$
$$= (15)(3,33) \checkmark + \frac{1}{2} (-4,5)(3,33)^2 \checkmark$$
$$\Delta x = 25 \text{ m } \checkmark$$

(4)

4.3 **OPTION 1/OPSIE 1**

$$v_f^2 = v_i^2 + 2a\Delta x \checkmark$$
$$0^2 \checkmark = 30^2 + 2(-4,5)\Delta x \checkmark$$
$$\Delta x = 100 \text{ m} \checkmark$$

Car B \checkmark has a larger stopping distance (100 m > 25 m) \checkmark /Kar B het 'n groter stopafstand (100 m > 25 m).

OPTION 2/OPSIE 2

$$v_f = v_i + a\Delta t \checkmark$$
$$0 \checkmark = 30 + (-4,5)\Delta t \checkmark$$
$$\Delta t = 6,67 \text{ s} \checkmark$$

Car B \checkmark it takes longer to stop hence larger stopping distance \checkmark / Kar B dit neem langer om tot stilstand te kom dus 'n groter stopafstand

IF/INDIEN

Car B \checkmark it has a higher velocity than car A and therefore have a larger stopping distance at the same acceleration \checkmark Max: (2/6)
Kar B dit het 'n hoër snelheid as kar A en het dus 'n groter stopafstand met dieselfde versnelling Maks: (2/6)

(6)

4.4 The greater/larger the speed, the larger the stopping distance \checkmark if acceleration is constant. \checkmark /Hoe groter die spoed, hoe groter die stopafstand indien versnelling konstant is.

(2)
[18]

QUESTION 5/VRAAG 5

5.1 The energy an object has because of its position in the gravitational field \checkmark relative to some reference point. \checkmark /Die energie wat 'n voorwerp het as gevolg van die posisie daarvan in die gravitasieveld relatief tot 'n sekere verwysingspunt.

(2)

5.2 $E_p = mgh \checkmark$
 $= (65)(9,8)(4,5) \checkmark$
 $= 2\,866,5 \text{ J} \checkmark$

(3)

5.3 The net/total mechanical energy (sum of kinetic and gravitational potential energy) in an isolated/closed system \checkmark remains constant/ is conserved \checkmark /Die netto/totale meganiese energie in 'n geïsoleerde/geslote sisteem bly konstant/bly konstant.

(2)

5.4 $(E_p + E_k)_{\text{top/bo}} = (E_p + E_k)_{\text{bottom/onder}} \checkmark$
 $mgh + 0 = mgh + \frac{1}{2}mv^2 \checkmark$
 $(65)(9,8)(4,5) \checkmark = 0 + \frac{1}{2}(65)v^2 \checkmark$
 $v = 9,39 \text{ m}\cdot\text{s}^{-1} \checkmark$

OR/OF

$$(E_p + E_k)_{\text{top/bo}} = (E_p + E_k)_{\text{bottom/onder}} \checkmark$$
$$mgh + 0 = mgh + \frac{1}{2}mv^2 \checkmark$$
$$2\,866,5 \checkmark = 0 + \frac{1}{2}(65)v^2 \checkmark$$
$$v = 9,39 \text{ m}\cdot\text{s}^{-1} \checkmark$$

(4)

5.5

OPTION 1/OPSIE 1

$$\begin{aligned} (E_p + E_k)_{\text{top/bo}} &= (E_p + E_k)_{\text{bottom/onder}} \quad \checkmark \\ mgh + 0 &= mgh + \frac{1}{2}mv^2 \quad \checkmark \\ (65)(9,8)h \quad \checkmark + 0 &= 0 + \frac{1}{2} \times 65 \times (9,39)^2 \quad \checkmark \\ 637 h &= 2\,865,6 \\ h &= 4,49 \text{ m} \end{aligned}$$

No✓/Nee. $h = 4,49 \text{ m} < 6 \text{ m}$ ✓

OPTION 2/OPSIE 2

$$\begin{aligned} E_{p \text{ at } Y} &= mgh \quad \checkmark \\ &= (65)(9,8)(6) \quad \checkmark \\ &= 3\,822 \text{ J} \quad \checkmark \end{aligned}$$

$E_{\text{mech}} < E_{p \text{ at } Y}$ ✓ therefore he will not reach point Y ✓ / $E_{\text{meg}} < E_p$ by Y *daarom sal hy nie punt Y bereik nie*

(5)
[16]

QUESTION 6/VRAAG 6

6.1

Difference/Verskil	Similarity/Ooreenkoms
Amplitudes✓	Wavelength✓/Golflengte Period/Tydperk Frequency/Frekwensie Transverse/Transversaal (Any one)/(Enige een)

(2)

6.2.1 A and/en B✓

OR/OF

C and/en D✓

OR/OF

B and/en C

OR/OF

A and/en D

(1)

6.2.2 15 (mm) ✓

(1)

6.3 The number of waves/wave pulses✓ passing a point per second.✓ / Die getal golwe/golfpulse wat per sekonde by 'n punt verby beweeg.

(2)

6.4.1

$$\begin{aligned} f &= \frac{1}{T} \quad \checkmark \\ &= \frac{1}{1,5} \quad \checkmark \\ &= 0,67 \text{ Hz} \quad \checkmark \end{aligned}$$

(3)

<p>6.4.2</p> <p>POSITIVE MARKING FROM 6.4.1 POSITIEWE NASIEN VANAF 6.1 OPTION 1/OPSIE 1</p> <p>$v = f\lambda$ ✓ = (0,67)(0,1) ✓ = 0,067 m·s⁻¹ ✓</p>	<p>OPTION 2/OPSIE 2</p> <p>$v = \frac{\Delta x}{\Delta t}$ or/of speed = $\frac{\text{distance}}{\text{time}}$ ✓ = $\frac{0,1}{1,5}$ ✓ = 0,067 m·s⁻¹</p>
--	--

(3)
[12]

QUESTION 7/VRAAG 7

7.1.1 What is the relationship between the speed of sound and temperature? ✓✓/
Wat is die verband tussen die spoed van klank en temperatuur?

OR/OF

How will the temperature affect the speed of sound? ✓✓/*Hoe sal die temperatuur die spoed van klank beïnvloed?*

OR/OF

What is the relationship between the time taken for the sound to travel and temperature? ✓✓/*Wat is die verband tussen die spoed van klank en temperatuur?*

(2)

Marking criteria/Nasienriglyne:	
Dependent and independent variables correctly identified. <i>Afhanklike en onafhanklike veranderlikes korrek geïdentifiseer.</i>	✓
Ask a question about the relationship between the independent and dependent variables./ <i>Vra 'n vraag oor die verwantskap tussen die afhanklike en onafhanklike veranderlikes.</i>	✓

7.1.2 Temperature ✓/*Temperatuur* (1)

7.1.3 Speed of sound ✓/Time taken for the sound to travel./*Spoed van klank/Tyd geneem vir die klank om te beweeg.* (1)

7.2 $v = \frac{\Delta x}{\Delta t}$ **or/of** speed = $\frac{\text{distance}}{\text{time}}$ ✓
= $\frac{50}{0,146}$ ✓
= 342,47 m·s⁻¹ ✓ (3)

7.3 The speed of sound increases / time taken for the sound to travel decreases / as the temperature increases. ✓✓/*Die spoed van klank neem toe / tyd geneem vir die klank om te beweeg neem af soos die temperatuur toeneem.* (2)

7.4 Echo ✓/*Eggo* (1)
[10]

QUESTION 8/VRAAG 8

8.1 Accelerating charges ✓/*Versnelde ladings* (1)

8.2 Gamma rays ✓/*Gammastrale* (1)

- 8.3 It has the highest frequency ✓ Energy is directly proportional to frequency ✓ /
 $E \propto f$ /
Dit het die hoogste frekwensie. Energie is direk eweredig aan die frekwensie/
 $E \propto f$ (2)

8.4.1	<p>OPTION 1/OPSIE 1</p> <p>$c = f\lambda$ ✓ $3 \times 10^8 = f(600 \times 10^{-10})$ ✓ $f = 5 \times 10^{15} \text{ Hz}$ ✓</p> <p>Ultraviolet ✓ / <i>Ultraviolet</i></p>	<p>OPTION 2/OPSIE 2</p> <p>$E = \frac{hc}{\lambda}$ $= \frac{(6,63 \times 10^{-34})(3 \times 10^8)}{600 \times 10^{-10}}$ ✓ $= 3,315 \times 10^{-18} \text{ J}$</p> <p>$E = hf$ $3,315 \times 10^{-18} = (6,63 \times 10^{-34})f$ $f = 5 \times 10^{15} \text{ Hz}$ ✓</p> <p>Ultraviolet ✓ / <i>Ultraviolet</i></p>
-------	--	--

✓ Any one
Enige een

(4)

- 8.4.2 **POSITIVE MARKING FROM 8.4.1/POSITIEWE NASIEN VANAF 8.4.1**
 Sterilisation of medical equipment. ✓ / *Sterilisasie van mediese toerusting*
 Suntan beds / *Sonbeddens*
 Security in currency / *Veiligheid in valuta*
 Astronomy / *Astronomie*
(Any one/Any relevant use/Enige een/Enige relevante gebruik) (1)
[9]

QUESTION 9/VRAAG 9

- 9.1 Ferromagnetic (material) ✓ / *Ferromagneties (materiaal)* (1)
- 9.2 B ✓ (1)
- 9.3 South ✓ / *Suid* (1)

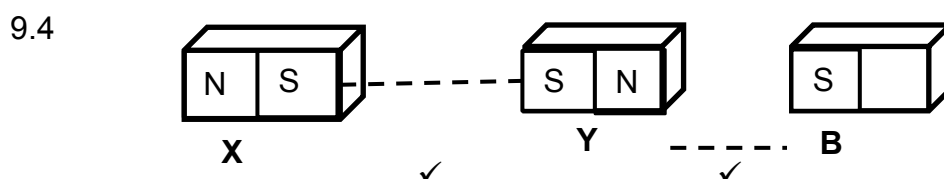

OR/OF

Magnets X repels Y / South pole ✓ / *Magneet X stoot Y af / Suidpool*

Magnet Y attracts B / South pole at B ✓ / *Magneet Y trek B aan / Suidpool by B* (2)

9.5

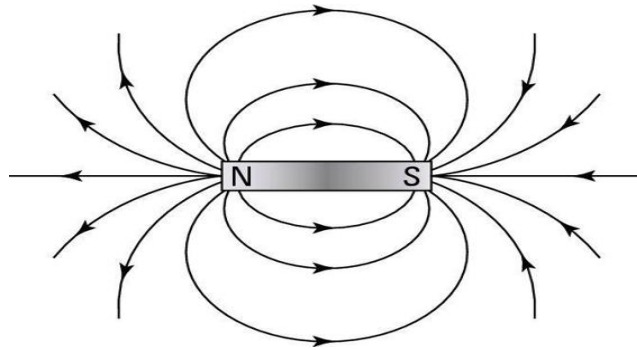

Marking criteria/Nasienkriteria	
Correct direction of field lines/Korrekte rigting van veldlyne	✓
Shape of the magnetic field/Vorm van die magneetveld	✓
No field lines crossing each other/Geen veldlyne kruis mekaar nie.	✓

(3)

9.6.1 Less than 5 cm ✓ / Minder as 5 cm

(1)

9.6.2 Magnitude of magnetic force is inversely proportional to the distance. ✓ B, is no longer attracting Y to the right ✓
 Grootte van magnetiese krag is omgekeerd eweredig aan die afstand. B, trek nie meer Y na regs aan nie

OR/OF

A decrease in distance increases the magnetic force. ✓ B, is no longer attracting Y to the right ✓
 'n Afname in afstand laat die magnetiese krag toeneem, B, trek nie meer Y na regs aan nie

(2)
[11]**QUESTION 10/VRAAG 10**

10.1 $n = \frac{Q}{e}$ ✓ or/of $\frac{Q}{q_e}$

$$30 = \frac{Q}{-1,6 \times 10^{-19}} \checkmark$$

$$Q = -4,8 \times 10^{-18} \text{ C} \checkmark$$

Accept/Aanvaar

$$n = \frac{Q}{e} \checkmark \text{ or/of } \frac{Q}{q_e}$$

$$30 = \frac{Q}{1,6 \times 10^{-19}} \checkmark$$

$$Q = 4,8 \times 10^{-18} \text{ C} \checkmark$$

(3)

10.2 Unlike/opposite charges ✓ attract ✓ / Ongelyksoortige/teenoorgestelde ladings trek mekaar aan.

(2)

- 10.3 The net/total charge in an isolated/closed system remains constant/is conserved ✓✓ Die netto/totale lading in 'n geïsoleerde/geslote sisteem bly konstant. (2)

NOTE/LET WEL:

If any of the underlined words/phrases are omitted in the correct context: minus 1 mark.)

Indien enige van die onderstreepte woorde/frases in die korrekte konteks weggelaat is: minus een punt.)

- 10.4 **POSITIVE MARKING FROM 10.1/POSITIEWE NASIEN VANAF 10.1**

$$\begin{aligned}
 Q_{\text{net/netto}} &= \frac{Q_1 + Q_2}{2} \checkmark \\
 &= \frac{4 \times 10^{-18} + (-4,8 \times 10^{-18})}{2} \checkmark \\
 &= -4 \times 10^{-19} \text{ C} \checkmark
 \end{aligned}$$

(4)
[11]

QUESTION 11/VRAAG 11

- 11.1.1 (a) $V_1 = 24 \text{ (V)}$ ✓ (1)

- (b) $A_1 = 0 \text{ (A)}$ ✓ (1)

<p>OPTION 1/OPSIE 1</p> $ \begin{aligned} \frac{1}{R_p} &= \frac{1}{R_1} + \frac{1}{R_2} \checkmark \\ &= \frac{1}{8} + \frac{1}{8} \checkmark \\ R_p &= 4 \Omega \end{aligned} $ $ \begin{aligned} R_T &= R_s + R_p \\ &= 8 + 4 \checkmark \\ &= 12 \Omega \checkmark \end{aligned} $	<p>OPTION 2/OPSIE 2</p> $ \begin{aligned} R_p &= \frac{\text{product / produk}}{\text{sum / som}} \checkmark \\ &= \frac{(8)(8)}{8 + 8} \checkmark \\ &= 4 \Omega \end{aligned} $ $ \begin{aligned} R_T &= R_s + R_p \\ &= 8 + 4 \checkmark \\ &= 12 \Omega \checkmark \end{aligned} $
---	---

(4)

11.1.3 **OPTION 1/OPSIE 1**
V divides in a ratio 8 : 4 ✓ (series)/V verdeel in 'n verhouding 8 : 4 (serie)
 $V_2 = \frac{8}{12} \times 24$ ✓ or/of $V_2 = \frac{2}{3} \times 24$
 $= 16 \text{ V}$ ✓

OPTION2 / OPSIE 2
POSITIVE MARKING FROM 11.1.2/POSITIEWE NASIEN VANAF 11.2.1
 $V = IR$
 $24 = I(12)$
 $I = 2 \text{ A}$
 $V = IR$ ✓
 $= (2)(8)$ ✓
 $= 16 \text{ V}$ ✓

(3)

11.1.4 $A_2 = A_3 \cdot \checkmark$

(1)

11.2.1 Resistance is directly proportional to the length of the conducting wire. ✓/
Weerstand is direk eweredig aan die lengte van die geleidingsdraad.

OR/OF

As the length of the wire increases, the resistance increases./Soos die lengte van die geleidingsdraad toeneem, neem die weerstand toe

(1)

11.2.2 $1,35 \Omega$ ✓ (Range/Variasiewydte: $1,3 \Omega$ to/tot $1,4 \Omega$)

(1)

[12]

TOTAL/TOTAAL: 150