



basic education

Department:
Basic Education
REPUBLIC OF SOUTH AFRICA

**NASIONALE
SENIOR SERTIFIKAAT**

GRAAD 12

FISIESE WETENSKAPPE: CHEMIE (V2)

NOVEMBER 2021

PUNTE: 150

TYD: 3 uur

Hierdie vraestel bestaan uit 15 bladsye en 4 gegewensblaaie.

INSTRUKSIES EN INLIGTING

1. Skryf jou sentrumnommer en eksamennommer in die toepaslike ruimtes op die ANTWOORDEBOEK neer.
2. Hierdie vraestel bestaan uit NEGE vrae. Beantwoord AL die vrae in die ANTWOORDEBOEK.
3. Begin ELKE vraag op 'n NUWE bladsy in die ANTWOORDEBOEK.
4. Nommer die antwoorde korrek volgens die nommeringstelsel wat in hierdie vraestel gebruik is.
5. Laat EEN reël tussen twee subvrae oop, bv. tussen VRAAG 2.1 en VRAAG 2.2.
6. Jy mag 'n nieprogrammeerbare sakrekenaar gebruik.
7. Jy mag toepaslike wiskundige instrumente gebruik.
8. Toon ALLE formules en substitusies in ALLE berekeninge.
9. Rond jou FINALE numeriese antwoorde tot 'n minimum van TWEE desimale plekke af.
10. Gee kort (bondige) motiverings, besprekings, ens. waar nodig.
11. Jy word aangeraai om die aangehegte GEGEWENSBLAAIE te gebruik.
12. Skryf netjies en leesbaar.

VRAAG 1: MEERVOUDIGEKEUSE-VRAE

Verskeie opsies word as moontlike antwoorde op die volgende vrae gegee. Kies die antwoord en skryf slegs die letter (A–D) langs die vraagnommers (1.1 tot 1.10) in die ANTWOORDEBOEK neer, bv. 1.11 E.

- 1.1 Watter formule toon die manier waarop atome in 'n molekule gebind is, maar toon nie al die bindingslyne nie?
- A Empiriese
- B Molekulêre
- C Struktuur
- D Gekondenseerde struktuur (2)
- 1.2 Watter EEN van die volgende verbindings het waterstofbindings tussen sy molekule?
- A $\text{CH}_3(\text{CH}_2)_2\text{CH}_3$
- B $\text{CH}_3\text{COCH}_2\text{CH}_3$
- C $\text{CH}_3\text{COOCH}_2\text{CH}_3$
- D $\text{CH}_3\text{CH}(\text{OH})\text{CH}_2\text{CH}_3$ (2)
- 1.3 Beskou die verbinding hieronder.

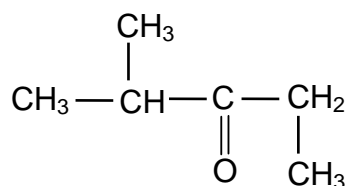

Watter EEN van die volgende is die IUPAC-naam van hierdie verbinding?

- A 2-metielpentan-3-oon
- B 4-metielpentan-3-oon
- C 2,3-dimetielbutan-2-oon
- D 2,2,4-trimetielpropan-2-oon (2)

- 1.4 'n 2 g-stuk magnesium reageer met 'n OORMAAT soutsuur volgens die volgende gebalanseerde vergelyking:

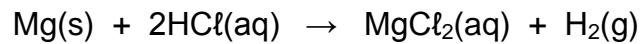

Watter EEN van die volgende veranderinge sal die OPBRENGS van $\text{H}_2\text{(g)}$ VERHOOG?

- A Maak die stuk magnesium fyn.
- B Gebruik 'n 3 g-stuk magnesium.
- C Gebruik 'n groter volume van die suur.
- D Gebruik 'n hoër konsentrasie van die suur. (2)

- 1.5 Die Maxwell-Boltzmann-verspreidingskurwe **P** verteenwoordig die aantal molekule teenoor kinetiese energie vir 'n sekere reaksie.

Kurwe **Q** word verkry nadat 'n verandering aan een reaksietoestand gemaak is.

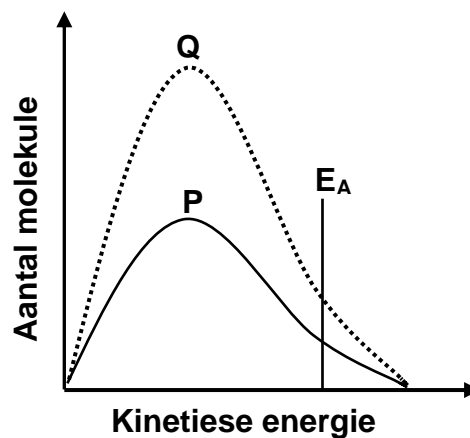

Watter EEN van die volgende veranderinge het tot kurwe **Q** gelei?

- A Byvoeging van 'n katalisator
- B Toename in temperatuur
- C Toename in aktiveringsenergie
- D Toename in die konsentrasie van die reaktanse (2)

- 1.6 Die uitdrukking vir die ewewigskonstante (K_c) van 'n hipotetiese reaksie word soos volg gegee:

$$K_c = \frac{[X]^3}{[Y]^2[Z]}$$

Watter EEN van die volgende vergelykings vir 'n reaksie by ewewig pas by die uitdrukking hierbo?

- A $Z(g) + 2Y(g) \rightleftharpoons 3X(s)$
 B $Z(aq) + 2Y(aq) \rightleftharpoons 3X(l)$
 C $Z(g) + Y_2(g) \rightleftharpoons 3X(aq) + Q(s)$
 D $Z(aq) + 2Y(aq) \rightleftharpoons 3X(aq) + Q(s)$ (2)

- 1.7 Twee verdunde sure met gelyke konsentrasies word in aparte proefbuise gevoeg, soos hieronder getoon.

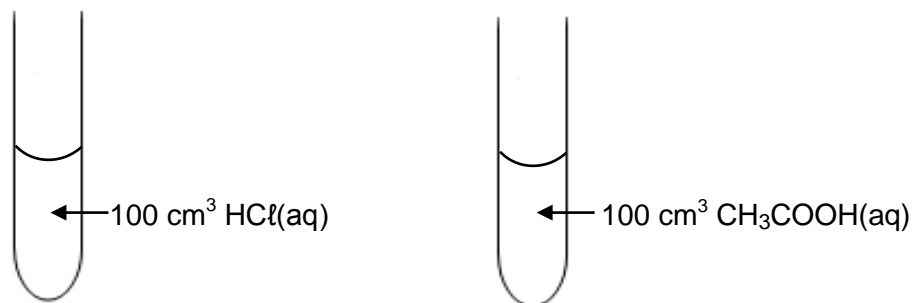

Beskou die volgende stellings oor hierdie sure:

- I:** Die pH van elk is kleiner as 7.
II: Beide sal teen dieselfde tempo met 5 g magnesiumpoeier reageer.
III: Beide sal dieselfde aantal mol NaOH(aq) neutraliseer.

Watter van die stellings hierbo is WAAR?

- A Slegs **I**
 B **I, II en III**
 C Slegs **I en III**
 D Slegs **II en III** (2)

1.8 Watter EEN van die volgende is die gekonjugeerde basis van H_2PO_4^- ?

- A PO_4^{3-}
- B HPO_4^{2-}
- C H_3PO_4
- D H_4PO_4^+

(2)

1.9 Die diagram hieronder stel 'n voltaïese sel voor.

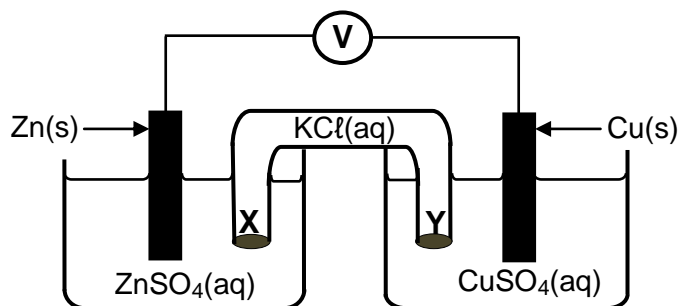

Watter EEN van die volgende beskryf die beweging van ione in die sel korrek?

	TIPE IONE	RIGTING VAN BEWEGING
A	$\text{Cl}^-(\text{aq})$	Y na X
B	$\text{SO}_4^{2-}(\text{aq})$	X na Y
C	$\text{Cu}^{2+}(\text{aq})$	Y na X
D	$\text{K}^+(\text{aq})$	Y na X

(2)

1.10 Die diagram hieronder verteenwoordig 'n sel wat gebruik word om koper te suiwer.

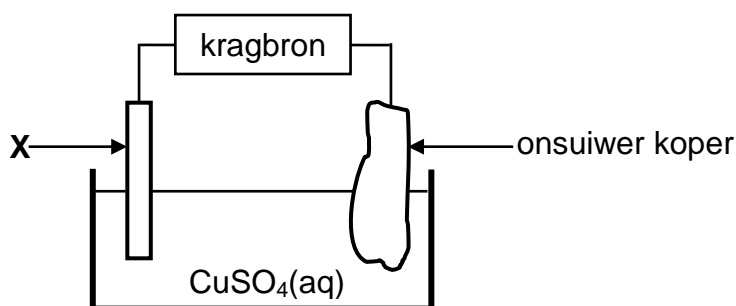

Watter EEN van die volgende stellings is WAAR?

- A X is van platinum gemaak.
- B Die massa van X neem toe.
- C X is die elektrode waar oksidasie plaasvind.
- D X is aan die positiewe terminaal van die kragbron verbind.

(2)
[20]

VRAAG 2 (Begin op 'n nuwe bladsy.)

Die letters **A** tot **H** in die tabel hieronder verteenwoordig agt organiese verbindings.

A	$\begin{array}{c} \text{H} \quad \text{O} \\ \quad \\ \text{H}-\text{C}-\text{C}-\text{O}-\text{H} \\ \\ \text{H} \end{array}$	B	$\begin{array}{c} \text{H} \quad \text{H} \\ \quad \\ \text{H}-\text{C}-\text{C}=\text{C}-\text{CH}_3 \\ \quad \\ \text{H} \quad \text{CH}_3 \end{array}$
C	$\text{CH}_3\text{CH}_2\text{CH}_2\text{COCH}_3$	D	$\text{C}_2\text{H}_6\text{O}$
E	C_2H_4	F	3-metielbutan-2-oon
G	$\begin{array}{cccccc} \text{H} & \text{Cl} & \text{H} & \text{H} & \text{H} & \text{H} \\ & & & & & \\ \text{H}-\text{C}-\text{C}-\text{C}-\text{C}-\text{C}-\text{C}-\text{H} \\ & & & & & \\ \text{H} & \text{H} & \text{CH}_3 & \text{H} & \text{Cl} & \text{H} \end{array}$	H	3-metielbutanaal

- 2.1 Definieer die term *onversadigde verbinding*. (2)
- 2.2 Skryf neer die:
- 2.2.1 Letter wat 'n ONVERSADIGDE verbinding voorstel (1)
- 2.2.2 NAAM van die funksionele groep van verbinding **C** (1)
- 2.2.3 Letter wat 'n KETTINGISOMEER van verbinding **C** voorstel (2)
- 2.2.4 IUPAC-naam van verbinding **G** (3)
- 2.2.5 Algemene formule van die homoloë reeks waaraan verbinding **E** behoort (1)
- 2.3 Definieer die term *funksionele isomere*. (2)
- 2.4 Vir verbinding **A**, skryf neer die:
- 2.4.1 Homoloë reeks waaraan dit behoort (1)
- 2.4.2 STRUKTUURFORMULE van sy FUNKSIONELE isomeer (2)
- 2.5 Verbinding **D** ondergaan 'n dehidrasie-reaksie. Skryf neer die:
- 2.5.1 IUPAC-naam van verbinding **D** (1)
- 2.5.2 Letter wat 'n produk van hierdie reaksie voorstel (1)
- 2.5.3 NAAM of FORMULE van die anorganiese reaktans wat in hierdie reaksie gebruik is (1)

[18]

VRAAG 3 (Begin op 'n nuwe bladsy.)

Die smeltpunte en kookpunte van vier reguitketting-ALKANE word in die tabel hieronder getoon.

VERBINDING	SMELTPUNT (°C)	KOOKPUNT (°C)
Pentaaan	-130	36,1
Heksaan	-94	69
Heptaaan	-90,6	98,4
Oktaan	-57	125

- 3.1 Definieer die term *smeltpunt*. (2)
- 3.2 Skryf die algemene gevolgtrekking neer wat oor die smeltpunte van reguitketting-alkane gemaak kan word. (2)
- 3.3 Noem die tipe Van der Waalskragte tussen molekule van oktaan. (1)
- 3.4 Skryf die oorheersende fase van die volgende alkane by -100 °C neer.
Kies uit GAS, VLOEISTOF of VASTE STOF.
- 3.4.1 Pentaaan (1)
- 3.4.2 Oktaan (1)
- 3.5 Heksaan word nou met 2,2-dimetielbutaan vergelyk.
- 3.5.1 Is die molekulêre massa van heksaan GROTER AS, KLEINER AS of GELYK AAN dié van 2,2-dimetielbutaan?
Gee 'n rede vir die antwoord. (2)
- 3.5.2 Is die kookpunt van 2,2-dimetielbutaan HOËR AS, LAER AS of GELYK AAN dié van heksaan? (1)
- 3.5.3 Verduidelik volledig die antwoord op VRAAG 3.5.2. (3)
- [13]**

VRAAG 4 (Begin op 'n nuwe bladsy.)

- 4.1 Verbinding **P** word as uitgangsgreëte in elk van twee reaksies gebruik soos in die vloeiagram hieronder getoon.

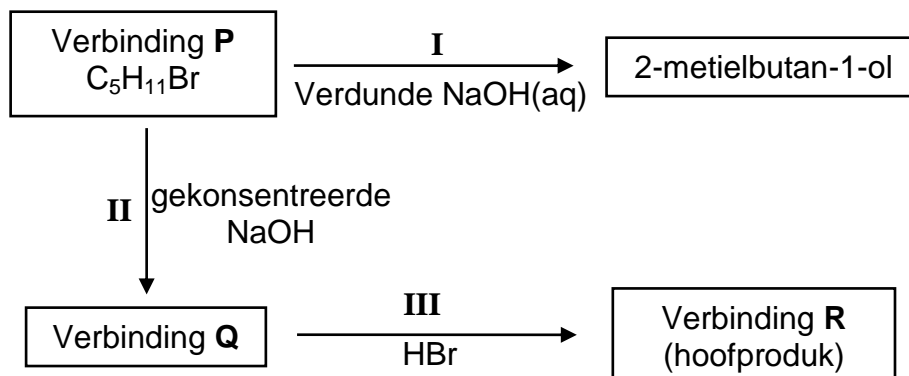

I, **II** en **III** verteenwoordig organiese reaksies.

- 4.1.1 Noem die tipe reaksie wat deur **I** voorgestel word. (1)
- 4.1.2 Is 2-metielbutan-1-ol 'n PRIMÊRE, SEKONDÊRE of TERSIÊRE alkohol? (2)
- Gee 'n rede vir die antwoord. (2)
- 4.1.3 Skryf die STRUKTUURFORMULE van verbinding **P** neer. (3)
- 4.1.4 Noem die tipe reaksie wat deur **II** voorgestel word. (1)
- 4.1.5 Aan watter homoloë reeks behoort verbinding **Q**? (1)
- 4.1.6 Noem die tipe reaksie wat deur **III** voorgestel word. (1)
- Kies uit ADDISIE, ELIMINASIE of SUBSTITUSIE. (1)
- 4.1.7 Skryf die IUPAC-naam van verbinding **R** neer. (2)

- 4.2 1,2-dibromopropaan kan uit but-2-een berei word met 'n drie-stapproses soos in die vloeddiagram hieronder getoon.

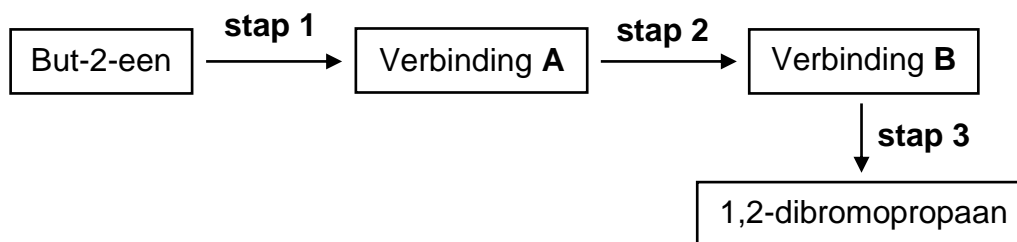

- 4.2.1 Gebruik GEKONDENSEERDE STRUKTUURFORMULES en skryf 'n gebalanseerde vergelyking vir **stap 1** neer. Dui die reaksietoestande op die pyl aan. (4)
- 4.2.2 Skryf die tipe reaksie in **stap 2** neer. (1)
- 4.2.3 Skryf die IUPAC-naam van verbinding **B** neer. (2)
- 4.2.4 Gebruik GEKONDENSEERDE STRUKTUURFORMULES om 'n gebalanseerde vergelyking vir **stap 3** neer te skryf. (3)
- [21]

VRAAG 5 (Begin op 'n nuwe bladsy.)

Die reaksie van 15 g van 'n ONSUIWER monster van kalsiumkarbonaat, CaCO_3 , met OORMAAT soutsuur, HCl , met 'n konsentrasie van $1,0 \text{ mol}\cdot\text{dm}^{-3}$, word gebruik om die tempo van 'n reaksie te ondersoek. Die gebalanseerde vergelyking vir die reaksie is:



Die volume van $\text{CO}_2(\text{g})$ geproduseer, word by gereelde intervalle gemeet. 'n Sketsgrafiek wat die totale volume koolstofdiksiedgas geproduseer as 'n funksie van tyd voorstel, word hieronder getoon.

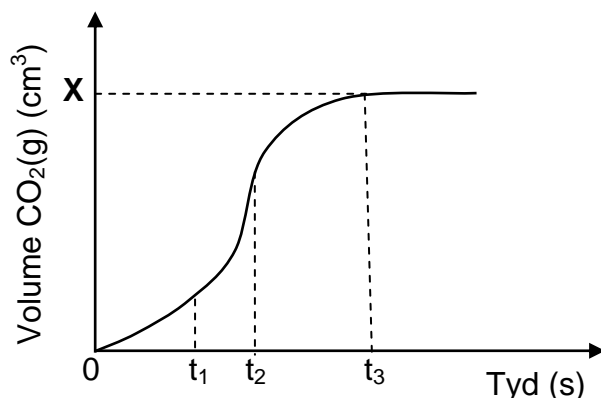

- 5.1 Definieer die term *reaksietempo*. (2)
- 5.2 Gee 'n rede waarom die gradiënt van die grafiek tussen t_2 en t_3 afneem. (1)
- 5.3 Veranderinge in die grafiek tussen t_1 en t_2 is as gevolg van temperatuurveranderinge in die reaksiemengsel.
- 5.3.1 Is die reaksie EKSOTERMIES of ENDOTERMIES? (1)
- 5.3.2 Verduidelik die antwoord deur na die grafiek te verwys. (3)
- 5.4 Die persentasie suiwerheid van die monster is 82,5%.
- Aanvaar dat die gas by 25°C versamel is en bereken die waarde van **X** op die grafiek. Neem die molêre gasvolume by 25°C as $24\,000 \text{ cm}^3$. (5)
- 5.5 Hoe sal die reaksietempo verander indien 15 g van 'n SUIWER monster van CaCO_3 met dieselfde HCl -oplossing reageer?
- Kies uit TOENEEM, AFNEEM of BLY DIESELFDE. (1)
- 5.6 Gebruik die botsingsteorie om die antwoord op VRAAG 5.5 te verduidelik. (2)

[15]

VRAAG 6 (Begin op 'n nuwe bladsy.)

Beskou die gebalanseerde vergelyking hieronder vir 'n hipotetiese reaksie wat in 'n verseëde 2 dm³-houer by 300 K plaasvind.

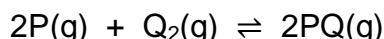

- 6.1 Definieer die term *chemiese ewewig*. (2)
- 6.2 Die hoeveelheid van elke stof teenwoordig in die ewewigmengsel by 300 K, word in die tabel hieronder getoon.

	HOEVEELHEID (mol) BY EWEWIG
P	0,8
Q ₂	0,8
PQ	3,2

Die temperatuur van die houer word nou na 350 K verhoog.

Wanneer 'n NUWE ewewig bereik word, word gevind dat 1,2 mol P(g) in die houer teenwoordig is.

- 6.2.1 Is die reaksiewarmte (ΔH) POSITIEF of NEGATIEF? (1)
- 6.2.2 Gebruik Le Chatelier se beginsel om die antwoord op VRAAG 6.2.1 te verduidelik. (3)
- 6.2.3 Bereken die ewewigskonstante by 350 K. (8)
- 6.2.4 Hoe sal die ewewigskonstante wat in VRAAG 6.2.3 bereken is, beïnvloed word wanneer die volume van die houer by konstante temperatuur verminder word?
- Kies uit TOENEEM, AFNEEM of BLY DIESELFDE.
- Gee 'n rede vir die antwoord. (2)
- 6.3 Meer Q₂(g) word nou by die reaksiemengsel by konstante temperatuur gevoeg.
- Hoe sal ELK van die volgende beïnvloed word?
- Kies uit TOENEEM, AFNEEM of BLY DIESELFDE.
- 6.3.1 Die opbrengs van PQ(g) (1)
- 6.3.2 Aantal mol van P(g) (1)

[18]

VRAAG 7 (Begin op 'n nuwe bladsy.)

7.1 Swawelsuur, H_2SO_4 , ioniseer in twee stappe soos volg:

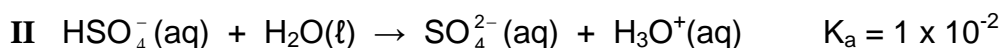
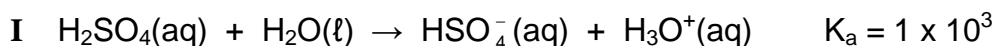

7.1.1 Definieer 'n *suur* in terme van die Lowry-Brønsted-teorie. (2)

7.1.2 Skryf die NAAM of FORMULE neer van die stof wat as 'n amfoliet in die vergelykings hierbo optree.

Gee 'n rede vir die antwoord. (2)

7.1.3 Die geleidingsvermoë van oplossings van $\text{HSO}_4^-(\text{aq})$ en $\text{H}_2\text{SO}_4(\text{aq})$ word vergelyk. Watter oplossing sal 'n LAER geleidingsvermoë hê?

Verduidelik die antwoord. (3)

7.2 Die pH van 'n soutsuuroplossing, $\text{HCl}(\text{aq})$, is 1,02 by 25 °C.

7.2.1 Bereken die konsentrasie van die $\text{HCl}(\text{aq})$. (3)

Hierdie HCl -oplossing reageer met natriumkarbonaat, Na_2CO_3 , volgens die volgende gebalanseerde vergelyking:

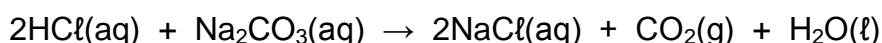

50 cm^3 van die HCl -oplossing word by 25 cm^3 van 'n 0,075 $\text{mol}\cdot\text{dm}^{-3}$ Na_2CO_3 -oplossing gevoeg.

7.2.2 Bereken die konsentrasie van die OORMAAT HCl in die nuwe oplossing. (8)

[18]

VRAAG 8 (Begin op 'n nuwe bladsy.)

Die tabel hieronder toon twee halfselle, **A** en **B**, wat gebruik is om 'n elektrochemiese sel onder STANDAARDTOESTANDE op te stel.

Halfsel A	$\text{Cu}^{2+}(\text{aq}) \mid \text{Cu}(\text{s})$
Halfsel B	$\text{Ag}^{+}(\text{aq}) \mid \text{Ag}(\text{s})$

- 8.1 Noem die energie-omskakeling wat in hierdie sel plaasvind. (1)
- 8.2 Bereken die massa silwernitrat, AgNO_3 , wat gebruik is om 150 cm^3 van die elektrolietoplossing in halfsel **B** te berei. (4)
- 8.3 Definieer die term *reduseermiddel*. (2)
- 8.4 Skryf neer die:
- 8.4.1 NAAM of FORMULE van die reduseermiddel (1)
- 8.4.2 Gebalanseerde vergelyking vir die reaksie wat plaasvind (3)
- 8.5 Bereken die aanvanklike emk van hierdie sel. (4)
- 8.6 Hoe sal die emk van die sel beïnvloed word indien die konsentrasie van die koperione in halfsel **A** toeneem? (1)
- Kies uit TOENEEM, AFNEEM of BLY DIESELFDE. [16]

VRAAG 9 (Begin op 'n nuwe bladsy.)

Die diagram hieronder toon 'n vereenvoudigde elektrolitiese sel wat gebruik word om 'n ring te elektroplateer.

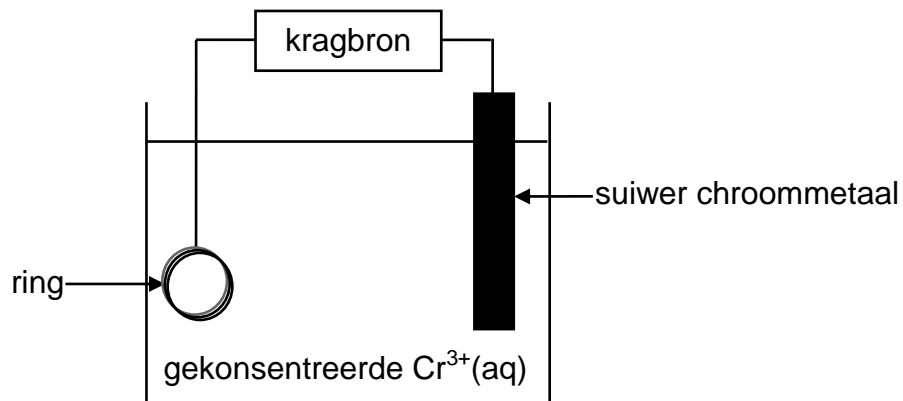

- 9.1 Definieer die term *elektroliet*. (2)
- 9.2 Is die suiwer chroommetaal die ANODE of die KATODE van die sel? Gee 'n rede vir die antwoord. (2)
- 9.3 Skryf die halfreaksie neer wat by die ring plaasvind. (2)
- 9.4 Bereken die totale lading oorgedra indien die massa van die suiwer chroom met 2 g verander. (5)
- [11]**

TOTAAL: 150

**DATA FOR PHYSICAL SCIENCES GRADE 12
PAPER 2 (CHEMISTRY)**

**GEGEWENS VIR FISIESE WETENSKAPPE GRAAD 12
VRAESTEL 2 (CHEMIE)**

TABLE 1: PHYSICAL CONSTANTS/TABEL 1: FISIESE KONSTANTES

NAME/NAAM	SYMBOL/SIMBOOL	VALUE/WAARDE
Standard pressure <i>Standaarddruk</i>	p^θ	$1,013 \times 10^5 \text{ Pa}$
Molar gas volume at STP <i>Molêre gasvolume by STD</i>	V_m	$22,4 \text{ dm}^3 \cdot \text{mol}^{-1}$
Standard temperature <i>Standaardtemperatuur</i>	T^θ	273 K
Charge on electron <i>Lading op elektron</i>	e	$-1,6 \times 10^{-19} \text{ C}$
Avogadro's constant <i>Avogadro-konstante</i>	N_A	$6,02 \times 10^{23} \text{ mol}^{-1}$

TABLE 2: FORMULAE/TABEL 2: FORMULES

$n = \frac{m}{M}$	$n = \frac{N}{N_A}$
$c = \frac{n}{V}$ or/of $c = \frac{m}{MV}$	$n = \frac{V}{V_m}$
$\frac{c_a v_a}{c_b v_b} = \frac{n_a}{n_b}$	$\text{pH} = -\log[\text{H}_3\text{O}^+]$
$K_w = [\text{H}_3\text{O}^+][\text{OH}^-] = 1 \times 10^{-14}$ at/by 298 K	
$E_{\text{cell}}^\theta = E_{\text{cathode}}^\theta - E_{\text{anode}}^\theta$ / $E_{\text{sel}}^\theta = E_{\text{katode}}^\theta - E_{\text{anode}}^\theta$ or/of $E_{\text{cell}}^\theta = E_{\text{reduction}}^\theta - E_{\text{oxidation}}^\theta$ / $E_{\text{sel}}^\theta = E_{\text{reduksie}}^\theta - E_{\text{oksidasie}}^\theta$ or/of $E_{\text{cell}}^\theta = E_{\text{oxidisingagent}}^\theta - E_{\text{reducingagent}}^\theta$ / $E_{\text{sel}}^\theta = E_{\text{oksideermiddel}}^\theta - E_{\text{reduseermiddel}}^\theta$	

TABLE 4A: STANDARD REDUCTION POTENTIALS
TABEL 4A: STANDAARD-REDUKSIEPOTENSIALE

Half-reactions/Halfreaksies	E^θ (V)
$F_2(g) + 2e^- \rightleftharpoons 2F^-$	+ 2,87
$Co^{3+} + e^- \rightleftharpoons Co^{2+}$	+ 1,81
$H_2O_2 + 2H^+ + 2e^- \rightleftharpoons 2H_2O$	+1,77
$MnO_4^- + 8H^+ + 5e^- \rightleftharpoons Mn^{2+} + 4H_2O$	+ 1,51
$Cl_2(g) + 2e^- \rightleftharpoons 2Cl^-$	+ 1,36
$Cr_2O_7^{2-} + 14H^+ + 6e^- \rightleftharpoons 2Cr^{3+} + 7H_2O$	+ 1,33
$O_2(g) + 4H^+ + 4e^- \rightleftharpoons 2H_2O$	+ 1,23
$MnO_2 + 4H^+ + 2e^- \rightleftharpoons Mn^{2+} + 2H_2O$	+ 1,23
$Pt^{2+} + 2e^- \rightleftharpoons Pt$	+ 1,20
$Br_2(l) + 2e^- \rightleftharpoons 2Br^-$	+ 1,07
$NO_3^- + 4H^+ + 3e^- \rightleftharpoons NO(g) + 2H_2O$	+ 0,96
$Hg^{2+} + 2e^- \rightleftharpoons Hg(l)$	+ 0,85
$Ag^+ + e^- \rightleftharpoons Ag$	+ 0,80
$NO_3^- + 2H^+ + e^- \rightleftharpoons NO_2(g) + H_2O$	+ 0,80
$Fe^{3+} + e^- \rightleftharpoons Fe^{2+}$	+ 0,77
$O_2(g) + 2H^+ + 2e^- \rightleftharpoons H_2O_2$	+ 0,68
$I_2 + 2e^- \rightleftharpoons 2I^-$	+ 0,54
$Cu^+ + e^- \rightleftharpoons Cu$	+ 0,52
$SO_2 + 4H^+ + 4e^- \rightleftharpoons S + 2H_2O$	+ 0,45
$2H_2O + O_2 + 4e^- \rightleftharpoons 4OH^-$	+ 0,40
$Cu^{2+} + 2e^- \rightleftharpoons Cu$	+ 0,34
$SO_4^{2-} + 4H^+ + 2e^- \rightleftharpoons SO_2(g) + 2H_2O$	+ 0,17
$Cu^{2+} + e^- \rightleftharpoons Cu^+$	+ 0,16
$Sn^{4+} + 2e^- \rightleftharpoons Sn^{2+}$	+ 0,15
$S + 2H^+ + 2e^- \rightleftharpoons H_2S(g)$	+ 0,14
$2H^+ + 2e^- \rightleftharpoons H_2(g)$	0,00
$Fe^{3+} + 3e^- \rightleftharpoons Fe$	- 0,06
$Pb^{2+} + 2e^- \rightleftharpoons Pb$	- 0,13
$Sn^{2+} + 2e^- \rightleftharpoons Sn$	- 0,14
$Ni^{2+} + 2e^- \rightleftharpoons Ni$	- 0,27
$Co^{2+} + 2e^- \rightleftharpoons Co$	- 0,28
$Cd^{2+} + 2e^- \rightleftharpoons Cd$	- 0,40
$Cr^{3+} + e^- \rightleftharpoons Cr^{2+}$	- 0,41
$Fe^{2+} + 2e^- \rightleftharpoons Fe$	- 0,44
$Cr^{3+} + 3e^- \rightleftharpoons Cr$	- 0,74
$Zn^{2+} + 2e^- \rightleftharpoons Zn$	- 0,76
$2H_2O + 2e^- \rightleftharpoons H_2(g) + 2OH^-$	- 0,83
$Cr^{2+} + 2e^- \rightleftharpoons Cr$	- 0,91
$Mn^{2+} + 2e^- \rightleftharpoons Mn$	- 1,18
$Al^{3+} + 3e^- \rightleftharpoons Al$	- 1,66
$Mg^{2+} + 2e^- \rightleftharpoons Mg$	- 2,36
$Na^+ + e^- \rightleftharpoons Na$	- 2,71
$Ca^{2+} + 2e^- \rightleftharpoons Ca$	- 2,87
$Sr^{2+} + 2e^- \rightleftharpoons Sr$	- 2,89
$Ba^{2+} + 2e^- \rightleftharpoons Ba$	- 2,90
$Cs^+ + e^- \rightleftharpoons Cs$	- 2,92
$K^+ + e^- \rightleftharpoons K$	- 2,93
$Li^+ + e^- \rightleftharpoons Li$	- 3,05

Increasing strength of oxidising agents/Toenemende sterkte van oksideermiddels

Increasing strength of reducing agents/Toenemende sterkte van reduseermiddels

TABLE 4B: STANDARD REDUCTION POTENTIALS
TABEL 4B: STANDAARD-REDUKSIEPOTENSIALE

Increasing strength of oxidising agents/Toenemende sterkte van oksideermiddels

Half-reactions/ <i>Halfreaksies</i>	E^θ (V)
$\text{Li}^+ + \text{e}^- \rightleftharpoons \text{Li}$	-3,05
$\text{K}^+ + \text{e}^- \rightleftharpoons \text{K}$	-2,93
$\text{Cs}^+ + \text{e}^- \rightleftharpoons \text{Cs}$	-2,92
$\text{Ba}^{2+} + 2\text{e}^- \rightleftharpoons \text{Ba}$	-2,90
$\text{Sr}^{2+} + 2\text{e}^- \rightleftharpoons \text{Sr}$	-2,89
$\text{Ca}^{2+} + 2\text{e}^- \rightleftharpoons \text{Ca}$	-2,87
$\text{Na}^+ + \text{e}^- \rightleftharpoons \text{Na}$	-2,71
$\text{Mg}^{2+} + 2\text{e}^- \rightleftharpoons \text{Mg}$	-2,36
$\text{Al}^{3+} + 3\text{e}^- \rightleftharpoons \text{Al}$	-1,66
$\text{Mn}^{2+} + 2\text{e}^- \rightleftharpoons \text{Mn}$	-1,18
$\text{Cr}^{2+} + 2\text{e}^- \rightleftharpoons \text{Cr}$	-0,91
$2\text{H}_2\text{O} + 2\text{e}^- \rightleftharpoons \text{H}_2(\text{g}) + 2\text{OH}^-$	-0,83
$\text{Zn}^{2+} + 2\text{e}^- \rightleftharpoons \text{Zn}$	-0,76
$\text{Cr}^{3+} + 3\text{e}^- \rightleftharpoons \text{Cr}$	-0,74
$\text{Fe}^{2+} + 2\text{e}^- \rightleftharpoons \text{Fe}$	-0,44
$\text{Cr}^{3+} + \text{e}^- \rightleftharpoons \text{Cr}^{2+}$	-0,41
$\text{Cd}^{2+} + 2\text{e}^- \rightleftharpoons \text{Cd}$	-0,40
$\text{Co}^{2+} + 2\text{e}^- \rightleftharpoons \text{Co}$	-0,28
$\text{Ni}^{2+} + 2\text{e}^- \rightleftharpoons \text{Ni}$	-0,27
$\text{Sn}^{2+} + 2\text{e}^- \rightleftharpoons \text{Sn}$	-0,14
$\text{Pb}^{2+} + 2\text{e}^- \rightleftharpoons \text{Pb}$	-0,13
$\text{Fe}^{3+} + 3\text{e}^- \rightleftharpoons \text{Fe}$	-0,06
$2\text{H}^+ + 2\text{e}^- \rightleftharpoons \text{H}_2(\text{g})$	0,00
$\text{S} + 2\text{H}^+ + 2\text{e}^- \rightleftharpoons \text{H}_2\text{S}(\text{g})$	+0,14
$\text{Sn}^{4+} + 2\text{e}^- \rightleftharpoons \text{Sn}^{2+}$	+0,15
$\text{Cu}^{2+} + \text{e}^- \rightleftharpoons \text{Cu}^+$	+0,16
$\text{SO}_4^{2-} + 4\text{H}^+ + 2\text{e}^- \rightleftharpoons \text{SO}_2(\text{g}) + 2\text{H}_2\text{O}$	+0,17
$\text{Cu}^{2+} + 2\text{e}^- \rightleftharpoons \text{Cu}$	+0,34
$2\text{H}_2\text{O} + \text{O}_2 + 4\text{e}^- \rightleftharpoons 4\text{OH}^-$	+0,40
$\text{SO}_2 + 4\text{H}^+ + 4\text{e}^- \rightleftharpoons \text{S} + 2\text{H}_2\text{O}$	+0,45
$\text{Cu}^+ + \text{e}^- \rightleftharpoons \text{Cu}$	+0,52
$\text{I}_2 + 2\text{e}^- \rightleftharpoons 2\text{I}^-$	+0,54
$\text{O}_2(\text{g}) + 2\text{H}^+ + 2\text{e}^- \rightleftharpoons \text{H}_2\text{O}_2$	+0,68
$\text{Fe}^{3+} + \text{e}^- \rightleftharpoons \text{Fe}^{2+}$	+0,77
$\text{NO}_3^- + 2\text{H}^+ + \text{e}^- \rightleftharpoons \text{NO}_2(\text{g}) + \text{H}_2\text{O}$	+0,80
$\text{Ag}^+ + \text{e}^- \rightleftharpoons \text{Ag}$	+0,80
$\text{Hg}^{2+} + 2\text{e}^- \rightleftharpoons \text{Hg}(\ell)$	+0,85
$\text{NO}_3^- + 4\text{H}^+ + 3\text{e}^- \rightleftharpoons \text{NO}(\text{g}) + 2\text{H}_2\text{O}$	+0,96
$\text{Br}_2(\ell) + 2\text{e}^- \rightleftharpoons 2\text{Br}^-$	+1,07
$\text{Pt}^{2+} + 2\text{e}^- \rightleftharpoons \text{Pt}$	+1,20
$\text{MnO}_2 + 4\text{H}^+ + 2\text{e}^- \rightleftharpoons \text{Mn}^{2+} + 2\text{H}_2\text{O}$	+1,23
$\text{O}_2(\text{g}) + 4\text{H}^+ + 4\text{e}^- \rightleftharpoons 2\text{H}_2\text{O}$	+1,23
$\text{Cr}_2\text{O}_7^{2-} + 14\text{H}^+ + 6\text{e}^- \rightleftharpoons 2\text{Cr}^{3+} + 7\text{H}_2\text{O}$	+1,33
$\text{Cl}_2(\text{g}) + 2\text{e}^- \rightleftharpoons 2\text{Cl}^-$	+1,36
$\text{MnO}_4^- + 8\text{H}^+ + 5\text{e}^- \rightleftharpoons \text{Mn}^{2+} + 4\text{H}_2\text{O}$	+1,51
$\text{H}_2\text{O}_2 + 2\text{H}^+ + 2\text{e}^- \rightleftharpoons 2\text{H}_2\text{O}$	+1,77
$\text{Co}^{3+} + \text{e}^- \rightleftharpoons \text{Co}^{2+}$	+1,81
$\text{F}_2(\text{g}) + 2\text{e}^- \rightleftharpoons 2\text{F}^-$	+2,87

Increasing strength of reducing agents/Toenemende sterkte van reduseermiddels



basic education

Department:
Basic Education
REPUBLIC OF SOUTH AFRICA

**NATIONAL
SENIOR CERTIFICATE
NASIONALE
SENIOR SERTIFIKAAT**

GRADE/GRAAD 12

**PHYSICAL SCIENCES: CHEMISTRY (P2)
FISIESE WETENSKAPPE: CHEMIE (V2)**

NOVEMBER 2021

MARKING GUIDELINES/NASIENRIGLYNE

MARKS/PUNTE: 150

**These marking guidelines consist of 21 pages.
*Hierdie nasienriglyne bestaan uit 21 bladsye.***

QUESTION 1/VRAAG 1

- 1.1 D ✓✓ (2)
- 1.2 D ✓✓ (2)
- 1.3 A ✓✓ (2)
- 1.4 B ✓✓ (2)
- 1.5 D ✓✓ (2)
- 1.6 D ✓✓ (2)
- 1.7 C ✓✓ (2)
- 1.8 B ✓✓ (2)
- 1.9 A ✓✓ (2)
- 1.10 B ✓✓ (2)
- [20]**

QUESTION 2/VRAAG 2

- 2.1 A compound that contains a double bond/multiple bond/does NOT contain only single bonds (between C atoms). ✓✓ **(2 or 0)**
'n Verbinding wat dubbelbindings/meervoudige bindings/NIE net enkelbindings (tussen C-atome) bevat NIE. (2 of 0) (2)
- 2.2
- 2.2.1 B / E ✓ (1)
- 2.2.2 Carbonyl (group bonded to two C atoms) ✓ **ACCEPT/AANVAAR**
Ketone/Ketoon (1)
Karboniel(groep gebind aan twee C-atome)
- 2.2.3 F ✓✓ (2)
- 2.2.4 2,5-dichloro-3-methylhexane/2,5-dichloro-3-metielheksaan

Marking criteria:

- Correct stem i.e. hexane. ✓
- All substituents (dichloro and methyl) correctly identified. ✓
- IUPAC name completely correct including numbering, sequence, hyphens and commas. ✓

Nasienkriteria:

- *Korrekte stam d.i. heksaan.* ✓
- *Alle substituenten (dichloro en metiel) korrek geïdentifiseer.* ✓
- *IUPAC-naam heeltemal korrek insluitende nommering, volgorde, koppeltekens en kommas.* ✓

(3)

2.2.5 C_nH_{2n} ✓ (1)

2.3 Compounds with the same molecular formula, ✓ but different functional groups/homologous series. ✓
Verbindings met dieselfde molekulêre formule, maar verskillende funksionele groepe/homoloë reekse. (2)

2.4
2.4.1 Carboxylic acids/Karboksielsure ✓ (1)

2.4.2

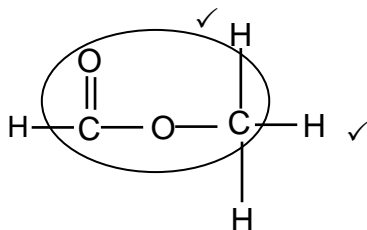

Marking criteria/Nasienkriteria:

- Whole structure correct/
Hele struktuur korrek: 2/2
- Only functional group correct/*Slegs funksionele groep korrek:* Max/Maks.: 1/2

IF/INDIEN

- More than one functional group:
Meer as een funksionele groep: 0/2

IF/INDIEN

- Molecular formula/*Molekulêre formule* 0/2
- Condensed structural formula /*Gekondenseerde struktuurformule* 1/2

2.5
2.5.1 Ethanol/*Etanol* ✓ (1)

2.5.2 E ✓ **ACCEPT/AANVAAR:** C_2H_4 (1)

2.5.3 (Concentrated) sulphuric acid/ H_2SO_4 /(concentrated) phosphoric acid/ H_3PO_4 ✓
(Gekonsentreerde) swawelsuur/ H_2SO_4 /(gekonsentreerde) fosforsuur/ H_3PO_4 (1)

[18]

QUESTION 3/VRAAG 3

3.1

Marking criteria/Nasienkriteria:

If any one of the underlined key phrases in the **correct context** is omitted, deduct 1 mark./Indien enige van die onderstreepte frases in die **korrekte konteks** uitgelaat is, trek 1 punt af.

The temperature at which solid and liquid phases are in equilibrium. ✓✓
Die temperatuur waarby die vastestof- en vloeistoffases van 'n stof in ewewig is.

(2)

3.2

Marking criteria

- Identification of independent variable. ✓
- Stating the relationship between dependent and independent variable. ✓

Nasienkriteria

- *Identifikasie van onafhanklike veranderlike.* ✓
- *Stel verwantskap tussen afhanklike en onafhanklike veranderlikes.* ✓
- As the chain length/number of C atoms/molecular mass/surface area/strength of the intermolecular forces ✓ increases, the melting points increase. ✓
OR
- As the chain length/ number of C atoms/molecular mass/surface area/strength of the intermolecular forces ✓ decreases, the melting points decrease. ✓
- *Wanneer die kettinglengte/aantal C-atome/molekulêre massa/oppervlak-area/sterkte van intermolekulêre kragte ✓ toeneem, neem die smeltpunte toe.*
OF
- *Wanneer die kettinglengte/aantal C-atome/molekulêre massa/oppervlak-area/sterkte van intermolekulêre kragte afneem, neem die smeltpunte af.*

(2)

3.3

London forces ✓
Londonkragte

ACCEPT/AANVAAR

Dispersion forces/induced dipole forces
Dispersiekragte/geïnduseerde dipoolkragte

(1)

3.4

3.4.1

Liquid/Vloeistof ✓

(1)

3.4.2

Solid/Vaste stof ✓

(1)

3.5

3.5.1

Equal to/Gelyk aan ✓

Same molecular formula/Isomers/same number and types of atoms/same number of C and H atoms ✓

Dieselfde molekulêre formule/Isomere/dieselfde aantal en soort atome/dieselfde aantal C- en H-atome

(2)

3.5.2

Lower than/Laer as ✓

(1)

3.5.3

Marking criteria:

- Compare structures. ✓
- Compare the strength of intermolecular forces. ✓
- Compare the energy required to overcome intermolecular forces. ✓

2,2-dimethylbutane:

- **Structure:**
More branched/more compact/more spherical/smaller surface area (over which intermolecular forces act). ✓
- **Intermolecular forces:**
Weaker/less intermolecular forces/Van der Waals forces/London forces/dispersion forces. ✓
- **Energy:**
Lesser energy needed to overcome or break intermolecular forces/Van der Waals forces. ✓

OR

Hexane

- **Structure:**
Longer chain length/unbranched/less compact/less spherical/larger surface area (over which intermolecular forces act). ✓
- **Intermolecular forces:**
Stronger/more intermolecular forces/Van der Waals forces/London forces/dispersion forces. ✓
- **Energy:**
More energy needed to overcome or break intermolecular forces/Van der Waals forces. ✓

Nasienkriteria:

- *Vergelyk strukture* ✓
- *Vergelyk die sterkte van intermolekulêre kragte.* ✓
- *Vergelyk die energie benodig om intermolekulêre kragte te oorkom.* ✓

2,2-dimetiëlbutaan:

- **Struktuur:**
Meer vertak/meer kompak/meer sferies/kleiner oppervlak (waaroor intermolekulêre kragte werk). ✓
- **Intermolekulêre kragte:**
Swakker/minder intermolekulêre kragte/Van der Waalskragte/Londonkragte/dispersiekragte. ✓
- **Energie:**
Minder energie benodig om intermolekulêre kragte/Van der Waalskragte/dispersiekragte/Londonkragte te oorkom/breek. ✓

OF

Heksaan

- **Struktuur:**
Langer kettlinglengte/onvertak/minder kompak/minder sferies/groter oppervlak (waaroor intermolekulêre kragte werk). ✓
- **Intermolekulêre kragte:**
Sterker/meer intermolekulêre kragte/Van der Waalskragte/Londonkragte/dispersiekragte. ✓
- **Energie:**
Meer energie benodig om intermolekulêre kragte/Van der Waalskragte/dispersiekragte/Londonkragte te oorkom/breek. ✓

(3)
[13]

QUESTION 4/VRAAG 4

4.1

4.1.1 Substitution/Hydrolysis ✓
Substitusie/Hidrolise

(1)

4.1.2 Primary (alcohol) ✓

ANY ONE:

- The C atom of the functional group is the terminal C atom.
- The C-atom bonded to the hydroxyl/-OH is bonded to (only) one other C-atom. ✓
- The hydroxyl/-OH is bonded to a C-atom which is bonded to two hydrogen atoms.
- The hydroxyl/-OH is bonded to a primary C atom/terminal C atom/first C atom.

Primêre (alkohol) ✓

ENIGE EEN:

- Die C-atoom van die funksionele groep is die terminale C-atoom.
- Die C-atoom wat aan die hidroksiel/-OH gebind is, is aan (slegs) een ander C-atoom gebind. ✓
- Die hidroksiel/-OH is gebind aan 'n C-atoom wat aan twee waterstofatome gebind is.
- Die hidroksiel/-OH is aan 'n primêre C-atoom/terminale C-atoom/eerste C-atoom gebind.

(2)

4.1.3

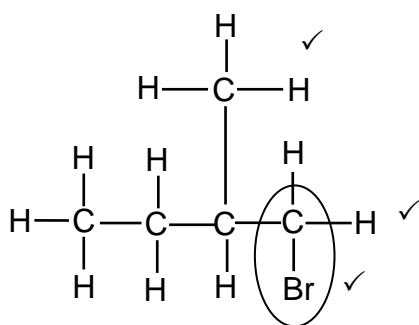

Marking criteria:

- Four C atoms in longest chain. ✓
- One methyl substituent on C2. ✓
- Bromo substituent on C1. ✓

Nasienkriteria:

- Vier C-atome in langste ketting. ✓
- Een metielsubstituent op C2. ✓
- Broomsustituent op C1. ✓

IF/INDIEN

Any error e.g. omission of H atoms, condensed or semi structural formula/Enige fout bv. weglating van H-atome, gekondenseerde of semi-struktuurformule. Max/Maks.: 2/3

(3)

4.1.4 Elimination/dehydrohalogenation/dehydrobromination ✓
Eliminasie/dehidrohalogenering/dehidrohalogenasie/dehidrobrominasie/
dehidrobromonering

(1)

4.1.5 Alkenes/Alkene ✓

(1)

4.1.6 Addition/Addisie ✓

(1)

4.1.7 2-bromo-2-methylbutane ✓
2-bromo-2-metielbutaan ✓

(2)

QUESTION 5/VRAAG 5

5.1

NOTE/LET WEL

Give the mark for per unit time only if in context of reaction rate.

Gee die punt vir per eenheidtyd slegs indien in konteks van reaksietempo.

ANY ONE

- Change in concentration ✓ of products/reactants per (unit) time. ✓
- Change in amount/number of moles/volume/mass of products or reactants per (unit) time.
- Amount/number of moles/volume/mass of products formed/reactants used per (unit) time.
- Rate of change in concentration/amount of moles/number of moles/volume/mass. ✓✓ (2 or 0)

ENIGE EEN

- Verandering in konsentrasie ✓ van produkte/reaktans per (eenheid) tyd. ✓
- Verandering in hoeveelheid/getal mol/volume/massa van produkte of reaktans per (eenheid) tyd.
- Hoeveelheid/getal mol/volume/massa van produkte gevorm/reaktans gebruik per (eenheid) tyd.
- Tempo van verandering in konsentrasie/ hoeveelheid mol/getal mol/volume/ massa. ✓✓ (2 of 0)

(2)

5.2

Reaction rate decreases./Concentration of HCl decreases./Concentration of reactant decreases./Reactants are used up/Mass of CaCO₃ decreases or is used up. ✓

Reaksietempo neem af./Konsentrasie van HCl neem af./Konsentrasie van reaktans neem af./Reaktans word opgebruik./Massa van CaCO₃ neem af of word opgebruik. ✓

(1)

5.3

5.3.1

Exothermic/Eksotermies ✓

(1)

5.3.2

- Gradient increases/becomes steeper. / Curve becomes steeper. ✓
- Reaction rate increases/More (or larger volume) of CO₂ is produced per unit time. ✓
- Temperature increases./Energy is released/Average kinetic energy of the molecules increases. ✓

- *Gradiënt neem toe/word steiler. / Kurwe word steiler. ✓*
- *Reaksietempo neem toe./Meer (of groter volume) CO₂ word produseer per eenheidtyd. ✓*
- *Temperatuur neem toe./Energie word vrygestel./Gemiddelde kinetiese energie van molekule neem toe. ✓*

(3)

5.4

<p>Marking criteria</p> <ul style="list-style-type: none"> • $m(\text{pure CaCO}_3) = \frac{82,5}{100} \times 15 \checkmark / V(\text{CO}_2) = \frac{82,5}{100} \times V(\text{CO}_2)$ from/uit 15 g CaCO₃ • Divide by 100 g·mol⁻¹. ✓ • Use mol ratio: $n(\text{CO}_2) = n(\text{CaCO}_3)$. ✓ • <u>Multiply $n(\text{CO}_2)$ by 24 000 cm³/24 dm³.</u> ✓ • Final answer: 2 976 cm³ ✓ • Range: 2880 to 2970 cm³ / 2,88 to 2,97 dm³ <p>Nasienkriteria</p> <ul style="list-style-type: none"> • $m(\text{suiwer CaCO}_3) = \frac{82,5}{100} \times 15 \checkmark / V(\text{CO}_2) = \frac{82,5}{100} \times V(\text{CO}_2)$ uit 15 g CaCO₃ • Deel deur 100 g·mol⁻¹. ✓ • Gebruik molverhouding: $n(\text{CO}_2) = n(\text{CaCO}_3)$. ✓ • Vermenigvuldig $n(\text{CO}_2)$ met 24 000 cm³/24 dm³. ✓ • Finale antwoord: 2 976 cm³ ✓ • Gebied: 2880 tot 2970 cm³ / 2,88 tot 2,97 dm³ 	
<p>OPTION 1/OPSIE 1</p> $m(\text{pure/suiwer CaCO}_3) = \frac{82,5}{100} \times 15 \checkmark$ $= 12,375 \text{ g}$ $n(\text{pure/suiwer CaCO}_3) = \frac{m}{M}$ $= \frac{12,375}{100} \checkmark$ $= 0,124 \text{ mol}$ $n(\text{CO}_2) = n(\text{CaCO}_3)$ $= 0,124 \text{ mol} \checkmark$ $V(\text{CO}_2) = 0,124 \times 24\ 000 \checkmark$ $= 2\ 976 \text{ cm}^3 \checkmark$ <p>OR/OF</p> $V(\text{CO}_2) = 0,124 \times 24 \checkmark$ $= 2,98 \text{ dm}^3 \checkmark$	<p>OPTION 2/OPSIE 2</p> <p>IF 15 g PURE CaCO₃ reacts: INDIEN 15 g SUIWER CaCO₃ reageer:</p> $n(\text{CaCO}_3) = \frac{m}{M}$ $= \frac{15}{100} \checkmark$ $= 0,15 \text{ mol}$ $n(\text{CO}_2) = n(\text{CaCO}_3) \checkmark$ $= 0,15 \text{ mol}$ $n(\text{CO}_2) = \frac{V}{V_M}$ $0,15 = \frac{V}{24\ 000} \checkmark / 0,15 = \frac{V}{24}$ $V = 3\ 600 \text{ cm}^3 / V = 3,6 \text{ dm}^3$ <p>Actual CO₂ formed: Werklike CO₂ gevorm:</p> $V(\text{CO}_2) = \frac{82,5}{100} \times 3\ 600 / 3,6 \checkmark$ $= 2\ 976 \text{ cm}^3 / 2,976 \text{ dm}^3 \checkmark$

(5)

OPTION 3/OPSIE 3

IF 15 g PURE CaCO₃ reacts:/INDIEN 15 g SUIWER CaCO₃ reageer:

$$n(\text{CaCO}_3) = \frac{m}{M}$$

$$= \frac{15}{100} \checkmark$$

$$= 0,15 \text{ mol}$$

$$n(\text{CO}_2) = n(\text{CaCO}_3) \checkmark$$

$$= 0,15 \text{ mol}$$

$$n(\text{CO}_2) = \frac{m}{M}$$

$$m(\text{CO}_2) = 0,15 \times 44$$

$$= 6,6 \text{ g}$$

$$82,5 = \frac{m_{\text{actual/werklik}}}{6,6} \times 100 \checkmark$$

$$m_{\text{(actual/werklik)}} = 5,445 \text{ g}$$

$$n(\text{CO}_2) = \frac{m}{M}$$

$$= \frac{5,445}{44}$$

$$= 0,12375 \text{ mol}$$

$$n(\text{CO}_2) = \frac{V}{V_M}$$

$$0,12375 = \frac{V}{24\ 000} \checkmark / 0,12375 = \frac{V}{24}$$

$$V = 2\ 976 \text{ cm}^3 / 2,976 \text{ dm}^3 \checkmark$$

(5)

5.5 Increases/*Toeneem* ✓

(1)

- 5.6
- More (CaCO₃) particles with correct orientation/exposed./ Greater (exposed) surface area. ✓
 - More effective collisions per unit time./Higher frequency of effective collisions. ✓
 - Meer (CaCO₃)-deeltjies met korrekte oriëntasie/blootgestel./ Groter (blootgestelde) reaksieoppervlakte. ✓
 - Meer effektiewe botsings per eenheid tyd./Hoër frekwensie van effektiewe botsings. ✓

NOTE/LET WEL

- If explanation in terms of CONCENTRATION: No mark for bullet 1.
Indien verduideliking in terme van KONSENTRASIE: Geen punt vir kolpunt 1.
- Bullets are marked independently./*Kolpunte word onafhanklik nagesien.*

(2)

[15]

QUESTION 6/VRAAG 6

6.1 (The stage in a chemical reaction when the) rate of forward reaction equals the rate of reverse reaction. ✓✓ (2 or 0)

OR

(The stage in a chemical reaction when the) concentrations of reactants and products remain constant. (2 or 0)

(Die stadium in 'n chemiese reaksie wanneer die) tempo van die voorwaartse reaksie gelyk is aan die tempo van die terugwaartse reaksie. (2 of 0)

OF

(Die stadium in 'n chemiese reaksie wanneer die) konsentrasies van reaktanse en produkte konstant bly. (2 of 0) (2)

6.2

6.2.1 Negative/Negatief ✓ (1)

6.2.2 • Increase in temperature favours an endothermic reaction.

Accept: Decrease in temperature favours an exothermic. ✓

• Reverse reaction is favoured./Concentration of reactants increases./
Concentration of products decreases. ✓

• (Forward) reaction is exothermic.

Accept: Reverse reaction is endothermic. ✓

• *Toename in temperatuur bevoordeel 'n endotermiese reaksie.* ✓

Aanvaar: *Afname in temperatuur bevoordeel die eksotermiese reaksie.*

• *Terugwaartse reaksie word bevoordeel./Konsentrasie van reaktanse neem toe./Konsentrasie van produkte neem af.* ✓

• *(Voorwaartse) reaksie is eksotermies.*

Aanvaar: *Terugwaartse reaksie is endotermies.* ✓ (3)

6.2.3

CALCULATIONS USING NUMBER OF MOLES
BEREKENINGE WAT GETAL MOL GEBRUIK

Marking criteria:

- a) Initial $n(P)$ and $n(Q_2)$ and $n(PQ)$ from table. ✓
- b) Change in $n(P)$ = equilibrium $n(P)$ – initial $n(P)$. ✓
- c) **USING** ratio: $P : Q_2 : PQ = 2 : 1 : 2$ ✓
- d) Equilibrium $n(Q_2)$ = initial $n(Q_2)$ + change in $n(Q_2)$ } ✓
 Equilibrium $n(PQ)$ = initial $n(PQ)$ - change in $n(PQ)$ } ✓
- e) Divide **equilibrium** amounts of P and Q_2 and PQ by 2 dm^3 . ✓
- f) Correct K_c expression (formulae in square brackets). ✓
- g) Substitution of equilibrium concentrations into K_c expression. ✓
- h) Final answer: 10,889 ✓

Nasienkriteria:

- a) *Aanvanklike $n(P)$ en $n(Q_2)$ en $n(PQ)$ uit tabel.* ✓
- b) *Verandering in $n(P)$ = ewewigs $n(P)$ – aanvanklike $n(P)$.* ✓
- c) **GEBRUIK** verhouding: $P : Q_2 : PQ = 2 : 1 : 2$ ✓
- d) *Ewewig $n(Q_2)$ = aanvanklike $n(Q_2)$ + verandering in $n(Q_2)$ } ✓
 Ewewig $n(PQ)$ = aanvanklike $n(PQ)$ - verandering in $n(PQ)$ } ✓*
- e) *Deel ewewigshoeveelhede van P en Q_2 en PQ deur 2 dm^3 .* ✓
- f) *Korrekte K_c -uitdrukking (formules in vierkanthakies).* ✓
- g) *Vervanging van ewewigskonsentrasies in K_c -uitdrukking.* ✓
- h) *Finale antwoord: 10,89 / 10,889* ✓

(3)

OPTION 1/OPSIE 1

	P	Q_2	PQ	
Initial quantity (mol) <i>Aanvangshoeveelheid (mol)</i>	0,8	0,8	3,2	✓(a)
Change (mol) <i>Verandering (mol)</i>	0,4 ✓(b)	0,2	0,4	✓(c)
Quantity at equilibrium (mol)/ <i>Hoeveelheid by ewewig (mol)</i>	1,2	1,0	2,8	✓(d)
Equilibrium concentration ($\text{mol} \cdot \text{dm}^{-3}$) <i>Ewewigskonsentrasie ($\text{mol} \cdot \text{dm}^{-3}$)</i>	0,6	0,5	1,4	✓(e)

$$\begin{aligned}
 K_c &= \frac{[PQ]^2}{[Q_2][P]^2} \quad \checkmark (f) \\
 &= \frac{1,4^2}{(0,5)(0,6)^2} \quad \checkmark (g) \\
 &= 10,89 \quad \checkmark (h)
 \end{aligned}$$

No K_c expression, correct substitution/Geen K_c -uitdrukking, korrekte substitusie: Max./Maks. $\frac{7}{8}$

Wrong K_c expression/Verkeerde K_c -uitdrukking: Max./Maks. $\frac{5}{8}$

OPTION 2/OPSIE 2

	PQ	P	Q ₂	
Initial quantity (mol) <i>Aanvangshoeveelheid (mol)</i>	3,2	0,8	0,8	✓(a)
Change (mol) <i>Verandering (mol)</i>	0,4	0,4 ✓(b)	0,2 ✓(c)	
Quantity at equilibrium (mol)/ <i>Hoeveelheid by ewewig (mol)</i>	2,8	1,2 ✓(d)	1,0	
Equilibrium concentration (mol·dm ⁻³) <i>Ewewigskonsentrasie (mol·dm⁻³)</i>	1,4	0,6	0,5	✓(e)

Reverse reaction
Terugwaartse reaksie:

$$K_c = \frac{[P]^2[Q_2]}{[PQ]^2} \quad \checkmark (f)$$

$$= \frac{(0,6)^2(0,5)}{(1,4)^2} \quad \checkmark (g)$$

$$K_c = 0,09$$

Forward reaction/*Voorwaartse reaksie:*

$$K_c = \frac{1}{0,09} \\ = 10,89 \quad \checkmark (h)$$

No K_c expression, correct substitution/Geen K_c-uitdrukking, korrekte substitusie: Max./Maks. $\frac{7}{8}$

Wrong K_c expression/Verkeerde K_c-uitdrukking: Max./Maks. $\frac{5}{8}$

**CALCULATIONS USING NUMBER OF MOLES
 BEREKENINGE WAT GETAL MOL GEBRUIK**

Marking criteria:

- a) Initial $n(P) = 4$ mol and $n(Q_2) = 2,4$ mol and $n(PQ) = 0$ ✓
- b) Change in $n(P) =$ equilibrium $n(P) -$ initial $n(P) = 2,8$ mol. ✓
- c) USING ratio: $P : Q_2 : PQ = 2 : 1 : 2$ ✓
- d) Equilibrium $n(Q_2) =$ initial $n(Q_2) +$ change in $n(Q_2)$ } ✓
 Equilibrium $n(PQ) =$ initial $n(PQ) -$ change in $n(PQ)$ }
- e) Divide equilibrium amounts of P and Q₂ and PQ by 2 dm^3 . ✓
- f) Correct K_c expression (formulae in square brackets). ✓
- g) Substitution of equilibrium concentrations into K_c expression. ✓
- h) Final answer: 10,89 / 10,889 ✓

Nasienkriteria:

- a) Aanvanklike $n(P) = 4$ mol en $n(Q_2) = 2,4$ mol en $n(PQ) = 0$. ✓
- b) Verandering in $n(P) =$ ewewigs $n(P) -$ aanvanklike $n(P) = 2,8$ mol. ✓
- c) GEBRUIK verhouding: $P : Q_2 : PQ = 2 : 1 : 2$ ✓
- d) Ewewig $n(Q_2) =$ aanvanklike $n(Q_2) +$ verandering in $n(Q_2)$ } ✓
 Ewewig $n(PQ) =$ aanvanklike $n(PQ) -$ verandering in $n(PQ)$ }
- e) Deel ewewigshoeveelhede van P en Q₂ en PQ deur 2 dm^3 . ✓
- f) Korrekte K_c -uitdrukking (formules in vierkanthakies). ✓
- g) Vervanging van ewewigskonsentrasies in K_c -uitdrukking. ✓
- h) Finale antwoord: 10,89 / 10,889 ✓

OPTION 3/OPSIE 3

	P	Q ₂	PQ	
Initial quantity (mol) Aanvangshoeveelheid (mol)	4	2,4	0	✓(a)
Change (mol) Verandering (mol)	2,8 ✓(b)	1,4	2,8	✓(c)
Quantity at equilibrium (mol)/ Hoeveelheid by ewewig (mol)	1,2	1,0	2,8	✓(d)
Equilibrium concentration (mol·dm ⁻³) Ewewigskonsentrasie (mol·dm ⁻³)	0,6	0,5	1,4	✓(e)

$$K_c = \frac{[PQ]^2}{[Q_2][P]^2} \checkmark (f)$$

$$= \frac{1,4^2}{(0,5)(0,6)^2} \checkmark (g)$$

$$= 10,89 \checkmark (h)$$

No K_c expression, correct substitution/Geen K_c -uitdrukking, korrekte substitusie: Max./Maks. $\frac{7}{8}$

Wrong K_c expression/Verkeerde K_c -uitdrukking: Max./Maks. $\frac{5}{8}$

CALCULATIONS USING CONCENTRATION
BEREKENINGE WAT KONSENTRASIE GEBRUIK

Marking criteria:

- a) Initial $c(P)$ and $c(Q_2)$ and $c(PQ)$ from table. ✓
- b) Change in $c(P)$ = equilibrium $c(P)$ – initial $c(P)$. ✓
- c) **USING** ratio: $P : Q_2 : PQ = 2 : 1 : 2$ ✓
- d) Equilibrium $c(Q_2) = \text{initial } c(Q_2) + \text{change in } c(Q_2)$ } ✓
 Equilibrium $c(PQ) = \text{initial } c(PQ) - \text{change in } c(PQ)$ }
- e) Divide **initial** amounts of P and Q_2 and PQ by 2 dm^3 . ✓
- f) Correct K_c expression (formulae in square brackets). ✓
- g) Substitution of equilibrium concentrations into K_c expression. ✓
- h) Final answer: $10,89 / 10,889$ ✓

Nasienriglyne:

- a) Aanvanklike $c(P)$ en $c(Q_2)$ en $c(PQ)$ uit tabel. ✓
- b) Verandering in $c(P)$ = ewewigs $c(P)$ – aanvanklike $c(P)$. ✓
- c) **GEBRUIK** verhouding: $P : Q_2 : PQ = 2 : 1 : 2$ ✓
- d) Ewewig $c(Q_2) = \text{aanvanklike } c(Q_2) + \text{verandering in } c(Q_2)$ } ✓
 Ewewig $c(PQ) = \text{aanvanklike } c(PQ) - \text{verandering in } c(PQ)$ }
- e) Deel **aanvangshoeveelhede** van P en Q_2 en PQ deur 2 dm^3 . ✓
- f) Korrekte K_c -uitdrukking (formules in vierkanthakies). ✓
- g) Vervanging van ewewigskonsentrasies in K_c -uitdrukking. ✓
- h) Finale antwoord: $10,89 / 10,889$ ✓

OPTION 4/OPSIE 4

	P	Q_2	PQ	
Initial concentration ($\text{mol}\cdot\text{dm}^{-3}$) Aanvangskonsentrasie ($\text{mol}\cdot\text{dm}^{-3}$)	0,4	0,4	1,6	✓ (a)
Change in concentration ($\text{mol}\cdot\text{dm}^{-3}$) Verandering in konsentrasie ($\text{mol}\cdot\text{dm}^{-3}$)	0,2 ✓ (b)	0,1	0,2	✓ (c)
Equilibrium concentration ($\text{mol}\cdot\text{dm}^{-3}$) Ewewigskonsentrasie ($\text{mol}\cdot\text{dm}^{-3}$)	0,6	0,5	1,4	✓ (d)

$$K_c = \frac{[PQ]^2}{[Q_2][P]^2} \quad \checkmark \text{ (f)}$$

$$= \frac{1,4^2}{(0,5)(0,6)^2} \quad \checkmark \text{ (g)}$$

$$= 10,89 \quad \checkmark \text{ (h)}$$

No K_c expression, correct substitution/Geen K_c -uitdrukking, korrekte substitusie: Max./Maks. $\frac{7}{8}$

Wrong K_c expression/Verkeerde K_c -uitdrukking:
 Max./Maks. $\frac{5}{8}$

(8)

6.2.4 Remains the same/Bly dieselfde ✓

Only temperature can change K_c ./Temperature remains constant. ✓
 Slegs temperatuur kan K_c verander./Temperatuur bly konstant.

(2)

6.3

6.3.1 Increases/Toeneem ✓

(1)

6.3.2 Decreases/Afneem ✓

(1)

[18]

QUESTION 7/VRAAG 7

7.1

7.1.1 (It is a) proton/ H_3O^+ (ion)/ H^+ (ion) donor. ✓✓
(Dit is 'n) proton/ H_3O^+ -(ioon)/ H^+ -(ioon)skenker. (2)

7.1.2 HSO_4^- /hydrogen sulphate ion/waterstofsulfaatioon ✓

ANY ONE:

- It acts as base in reaction I and as acid in reaction II. ✓
- Acts as acid and base.

ENIGE EEN:

- Dit reageer as basis in reaksie I en as suur in reaksie II.
- Reageer as suur en basis. (2)

7.1.3 HSO_4^- /Reaction (solution) II/Reaksie (oplossing) II ✓

Smaller K_a value/weaker acid ✓

Lower ion concentration/Incompletely ionised. ✓

Kleiner K_a -waarde/swakker suur ✓

Laer ionkonsentrasie/Onvolledig geïoniseer. ✓ (3)

7.2

7.2.1

OPTION 1/OPSIE 1	OPTION 2/OPSIE 2
pH = $-\log[H_3O^+]$ ✓ 1,02 ✓ = $-\log[H_3O^+]$ $[H_3O^+] = 0,0955 \text{ mol}\cdot\text{dm}^{-3}$ ✓	$\left. \begin{array}{l} \text{pH} = -\log[H_3O^+] \\ [H_3O^+] = 10^{-\text{pH}} \end{array} \right\}$ ✓ Any one/Enige = $10^{-1,02}$ ✓ = $0,0955 \text{ mol}\cdot\text{dm}^{-3}$ ✓
Therefore/Dus $[HC\ell] = 0,0955 \text{ mol}\cdot\text{dm}^{-3}$ (0,096/0,1 $\text{mol}\cdot\text{dm}^{-3}$)	Therefore/Dus $[HC\ell] = 0,0955 \text{ mol}\cdot\text{dm}^{-3}$ (0,096/0,1 $\text{mol}\cdot\text{dm}^{-3}$)

(3)

7.2.2 **POSITIVE MARKING FROM 7.2.1/POSITIEWE NASIEN VAN VRAAG 7.2.1**

Marking criteria:

- Formula: $c = \frac{n}{V} / \frac{c_a V_a}{c_b V_b} = \frac{n_a}{n_b}$ ✓
 - Calculate $n(\text{Na}_2\text{CO}_3)$: $0,075 \times 0,025$ ✓
 - Calculate $n(\text{HCl})$: $0,0955 \times 0,05 / 0,096 \times 0,05$ ✓
 - Use ratios: $n(\text{HCl}) = 2n(\text{Na}_2\text{CO}_3)$ ✓
 - $n(\text{HCl})_{\text{excess}} = n(\text{HCl})_{\text{initial}} - n(\text{HCl})_{\text{used}} = 0,00475 - 0,0038$ ✓✓
 - Substitute $0,075 \text{ dm}^3$ in $c = \frac{n}{V}$ ✓
 - Final answer: $0,013 \text{ mol}\cdot\text{dm}^{-3}$ ✓ ($1,3 \times 10^{-2} \text{ mol}\cdot\text{dm}^{-3}$)
- Range:** 0,01 to 0,02 $\text{mol}\cdot\text{dm}^{-3}$

Nasienkriteria:

- *Formule:* $c = \frac{n}{V} / \frac{c_a V_a}{c_b V_b} = \frac{n_a}{n_b}$ ✓
 - *Bereken* $n(\text{Na}_2\text{CO}_3)$: $0,075 \times 0,025$ ✓
 - *Bereken* $n(\text{HCl})$: $0,0955 \times 0,05 / 0,096 \times 0,05$ ✓
 - *Gebruik molverhouding:* $n(\text{HCl}) = 2n(\text{Na}_2\text{CO}_3)$ ✓
 - $n(\text{HCl})_{\text{oormaat}} = n(\text{HCl})_{\text{aanvanklik}} - n(\text{HCl})_{\text{gebruik}} = 0,00475 - 0,0038$ ✓✓
 - *Vervang* $0,075 \text{ dm}^3$ in $c = \frac{n}{V}$ ✓
 - *Finale antwoord:* $0,013 \text{ mol}\cdot\text{dm}^{-3}$ ✓ ($1,3 \times 10^{-2} \text{ mol}\cdot\text{dm}^{-3}$)
- Gebied:** 0,01 tot 0,02 $\text{mol}\cdot\text{dm}^{-3}$

OPTION 1/OPSIE 1

$$\begin{aligned}
 n(\text{Na}_2\text{CO}_3) &= cV \checkmark \\
 &= 0,075 \times 0,025 \checkmark \\
 &= 0,001875 \text{ mol} \qquad (1,875 \times 10^{-3} / 0,002 \text{ mol}) \\
 n(\text{HCl})_{\text{initial/aanvanklik}} &= cV \\
 &= 0,096 \times 0,05 \checkmark \\
 &= 0,00475 \text{ mol} \qquad (4,75 \times 10^{-3} / 0,005 \text{ mol}) \\
 n(\text{HCl})_{\text{used/gebruik}} &= 2n(\text{Na}_2\text{CO}_3) \checkmark \\
 &= 2(0,001875) \checkmark \\
 &= 0,0038 \text{ mol} \qquad (3,75 \times 10^{-3} / 0,004 \text{ mol}) \\
 n(\text{HCl})_{\text{excess/oormaat}} &= 0,00475 - 0,0038 \checkmark \checkmark \\
 &= 0,00095 \text{ mol} \qquad (9,5 \times 10^{-4} / 1 \times 10^{-3} \text{ mol}) \\
 c(\text{HCl}) &= \frac{n}{V} \\
 &= \frac{0,00095}{0,075} \checkmark \\
 &= 0,013 \text{ mol}\cdot\text{dm}^{-3} \checkmark \qquad (1,3 \times 10^{-2} \text{ mol}\cdot\text{dm}^{-3})
 \end{aligned}$$

OPTION 2/OPSIE 2

$$\frac{c_a V_a}{c_b V_b} = \frac{n_a}{n_b} \checkmark$$

$$\frac{c_a(50)\checkmark}{(0,075)(25)\checkmark} = \frac{2}{1}\checkmark$$

$$c(\text{HCl})_{\text{rea}} = 0,075 \text{ mol}\cdot\text{dm}^{-3}$$

$$c(\text{HCl})_{\text{excess/oormaat}} = 0,0955 - 0,075 \checkmark\checkmark$$

$$= 0,0205 \text{ mol}\cdot\text{dm}^{-3}$$

$$c_1 V_1 = c_2 V_2$$

$$(0,0205)(50) = c_2(75) \checkmark$$

$$c_2 = 0,014 \text{ mol}\cdot\text{dm}^{-3} \checkmark$$

(8)
[18]

QUESTION 8/VRAAG 8

8.1 Chemical (energy) to electrical (energy) ✓
 Chemiese (energie) na elektriese (energie)

(1)

8.2

Marking criteria:

- Any formula: $c = \frac{m}{MV} / c = \frac{n}{V} / n = \frac{m}{M} \checkmark$
- Substitute $1 \text{ mol}\cdot\text{dm}^{-3} \checkmark$
- Substitute $170 \text{ g}\cdot\text{mol}^{-1}$ [or 108 + 14 + 3(16)] and $0,15 \text{ dm}^3$ in correct formulae. ✓
- Final answer: 25,50 g ✓

Nasienkriteria:

- Enige formule: $c = \frac{m}{MV} / c = \frac{n}{V} / n = \frac{m}{M} \checkmark$
- Vervang $1 \text{ mol}\cdot\text{dm}^{-3} \checkmark$
- Vervang $170 \text{ g}\cdot\text{mol}^{-1}$ [of 108 + 14 + 3(16)] en $0,15 \text{ dm}^3$ in korrekte formules. ✓
- Finale antwoord: 25,50 g ✓

OPTION 1/OPSIE 1	OPTION 2/OPSIE 2
$c = \frac{m}{MV} \checkmark$ $1 = \frac{m}{170 \times 0,15} \checkmark$ $m = 25,50 \text{ g} \checkmark$	$n = cV \checkmark$ $= 1 \checkmark \times 0,15$ $= 0,15 \text{ mol}$ $m = nM$ $= (0,15)(170)$ $= 25,50 \text{ g} \checkmark$

(4)

8.3 **ANY ONE:**

- A substance that loses/donates electrons. ✓✓
- A substance that is oxidised.
- A substance whose oxidation number increases.

ENIGE EEN:

- 'n Stof wat elektrone verloor/skenk. ✓✓
- 'n Stof wat geoksideer word.
- 'n Stof wat waarvan die oksidasiegetal toeneem.

(2)

8.4

8.4.1 Copper/Cu/Koper ✓

(1)

8.4.2

Marking criteria/Nasienkriteria:

- Reactants ✓ Products ✓ Balancing ✓
Reaktanse Produkte Balansering
- Ignore double arrows./Ignoreer dubbelpyle.
- Ignore phases./Ignoreer fases.
- Marking rule 6.3.10./Nasienreël 6.3.10.

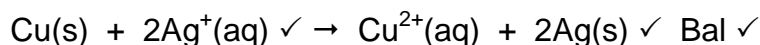

ACCEPT/AANVAAR:

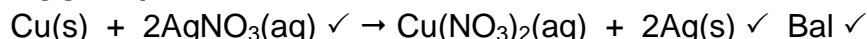

NOTE/LET WEL

- **IF** electrons are not cancelled – minus 1 mark
- **INDIEN** elektrone nie gekanselleer is nie – minus 1 punt

(3)

8.5

OPTION 1/OPSIE 1

$$E_{\text{cell}}^{\ominus} = E_{\text{reduction}}^{\ominus} - E_{\text{oxidation}}^{\ominus} \checkmark$$

$$= 0,80 \checkmark - (0,34) \checkmark$$

$$= 0,46 \text{ V } \checkmark$$

Notes/Aantekeninge

- Accept any other correct formula from the data sheet./Aanvaar enige ander korrekte formule vanaf gegewensblad.
- Any other formula using unconventional abbreviations, e.g. $E_{\text{cell}}^{\ominus} = E_{\text{OA}}^{\ominus} - E_{\text{RA}}^{\ominus}$ followed by correct substitutions:/Enige ander formule wat onkonvensionele afkortings gebruik bv. $E_{\text{sel}}^{\ominus} = E_{\text{OM}}^{\ominus} - E_{\text{RM}}^{\ominus}$ gevolg deur korrekte vervangings. $\frac{3}{4}$

OPTION 2/OPSIE 2

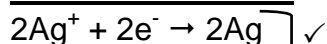

$E^{\ominus} = 0,80 \text{ V } \checkmark$

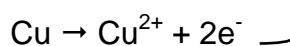

$E^{\ominus} = -0,34 \text{ V } \checkmark$

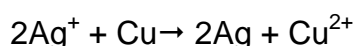

$E^{\ominus} = +0,46 \text{ V } \checkmark$

(4)

8.6 Decreases/Afneem ✓

(1)

[16]

QUESTION 9/VRAAG 9

9.1 ANY ONE: (2 or 0)

- A substance whose (aqueous) solution contains ions. ✓✓
- Substance that dissolves in water to give a solution that conducts electricity.
- A substance that forms ions in water / when melted.
- A solution that conducts electricity through the movement of ions.

ENIGE EEN: (2 of 0)

- 'n Stof waarvan die oplossing ione bevat. ✓✓
- 'n Stof wat in water oplos om 'n oplossing te vorm wat elektrisiteit gelej.
- 'n Stof wat ione in water vorm/ wanneer dit gesmelt word.
- 'n Oplossing wat elektrisiteit gelej deur die beweging van ione. (2)

9.2 Anode ✓



Chromium is oxidised./Oxidation takes place (at the anode)./Chromium (it) loses electrons./Mass decreases./ $\text{Cr} \rightarrow \text{Cr}^{3+} + 3\text{e}^-$ ✓
Chroom word geoksideer./Oksidasie vind (by die anode) plaas./Chroom (dit) verloor elektrone./Massa neem af./ $\text{Cr} \rightarrow \text{Cr}^{3+} + 3\text{e}^-$

NOTE/LET WEL:

If half-reaction is used, it must be correct/Indien halfreaksie gebruik word, moet dit korrek wees: $\text{Cr} \rightarrow \text{Cr}^{3+} + 3\text{e}^-$ (2)

9.3 $\text{Cr}^{3+}(\text{aq}) + 3\text{e}^- \rightarrow \text{Cr}(\text{s})$ ✓✓

Ignore phases./Ignoreer fases.

Marking guidelines/Nasienkriteria

- $\text{Cr}^{3+} + 3\text{e}^- \rightleftharpoons \text{Cr}$ $\frac{1}{2}$ $\text{Cr} \rightleftharpoons \text{Cr}^{3+} + 3\text{e}^-$ $\frac{0}{2}$
 - $\text{Cr} \leftarrow \text{Cr}^{3+} + 3\text{e}^-$ $\frac{2}{2}$ $\text{Cr} \rightarrow \text{Cr}^{3+} + 3\text{e}^-$ $\frac{0}{2}$
 - Ignore if charge omitted on electron./Ignoreer indien lading weggelaat op elektron.
 - If charge (+) omitted on Cr^{3+} /Indien lading (+) weggelaat op Cr^{3+} : Max./Maks: $\frac{1}{2}$
- Example/Voorbeeld: $\text{Cr}^{3+} + 3\text{e}^- \rightarrow \text{Cr}$ ✓ (2)

9.4

<p>Marking criteria:</p> <ul style="list-style-type: none"> Substitute $52 \text{ g}\cdot\text{mol}^{-1}$ in $n = \frac{m}{M}$ /ratio ✓ Use mol ratio: $n(\text{electrons}): n(\text{Cr}) = 3 : 1$. ✓ Number of electrons = $n \times 6,02 \times 10^{23}$ /No of Cr atoms = $n \times 6,02 \times 10^{23}$ /ratio. ✓ Total charge = number of electrons $\times 1,6 \times 10^{-19}$ /ratio. ✓ Final answer: 11 113,85 C ✓ <p>Range: 11 076,8 to 11 580 C</p> <p>Nasienkriteria:</p> <ul style="list-style-type: none"> Vervang $52 \text{ g}\cdot\text{mol}^{-1}$ in $n = \frac{m}{M}$ /verhouding ✓ Gebruik molverhouding: $n(\text{elektrone}) : n(\text{Cr}^{3+}) = 3 : 1$. ✓ Aantal elektrone = $n \times 6,02 \times 10^{23}$ /Aantal Cr-atome = $n \times 6,02 \times 10^{23}$ /verhouding. ✓ Totale lading = aantal elektrone $\times 1,6 \times 10^{-19}$ /verhouding. ✓ Finale antwoord: 11 113,85 C ✓ <p>Gebied: 11 076,8 tot 11 580 C</p>					
<p>OPTION 1/OPSIE 1</p> $n = \frac{m}{M}$ $= \frac{2}{52} \checkmark$ $= 0,038 \text{ mol} \quad (0,04 \text{ mol})$ <p style="margin-left: 40px;">↓</p> $n(e^-) = 3n(\text{Cr}) \checkmark$ $= 3(0,038)$ $= 0,115 \text{ mol} \quad (0,12 \text{ mol})$ <p style="margin-left: 40px;">↓</p> $\text{Number } (e^-) = 0,115 \times 6,02 \times 10^{23} \checkmark$ $= 6,946 \times 10^{22}$ <p style="margin-left: 40px;">↓</p> $Q = 6,95 \times 10^{22} \times 1,6 \times 10^{-19} \checkmark$ $= 11 113,85 \text{ C} \checkmark$	<p>OPTION 2/OPSIE 2</p> $n = \frac{m}{M}$ $= \frac{2}{52} \checkmark$ $= 0,038 \text{ mol} \quad (0,04 \text{ mol})$ <p>Number Cr atoms</p> $= 0,038 \times 6,02 \times 10^{23} \checkmark$ $= 2,315 \times 10^{22}$ <p style="margin-left: 40px;">↓</p> $\text{Number } (e^-) = 3N(\text{Cr}) \checkmark$ $= 3(2,315 \times 10^{22})$ $= 6,946 \times 10^{22}$ <p style="margin-left: 40px;">↓</p> $Q = 6,95 \times 10^{22} \times 1,6 \times 10^{-19} \checkmark$ $= 11 113,85 \text{ C} \checkmark$				
<p>OPTION 3/OPSIE 3</p> $n = \frac{m}{M}$ $= \frac{2}{52} \checkmark$ $= 0,038 \text{ mol}$ <p style="margin-left: 40px;">↓</p> $n(e^-) = 3n(\text{Cr}) \checkmark$ $= 3(0,038)$ $= 0,115 \text{ mol}$ <p style="margin-left: 40px;">↓</p> <table style="width: 100%; border: none;"> <tr> <td style="width: 50%;">1 mol</td> <td style="width: 50%;">96 500 C ✓</td> </tr> <tr> <td>0,115 mol</td> <td>11 134,62 C ✓✓</td> </tr> </table>	1 mol	96 500 C ✓	0,115 mol	11 134,62 C ✓✓	
1 mol	96 500 C ✓				
0,115 mol	11 134,62 C ✓✓				

(5)
[11]

TOTAL/TOTAAL: 150