



basic education

Department:
Basic Education
REPUBLIC OF SOUTH AFRICA

**SENIOR CERTIFICATE/
NATIONAL SENIOR CERTIFICATE**

GRADE 12

PHYSICAL SCIENCES: CHEMISTRY (P2)

NOVEMBER 2020

MARKS: 150

TIME: 3 hours

This question paper consists of 15 pages and 4 data sheets.

INSTRUCTIONS AND INFORMATION

1. Write your examination number and centre number in the appropriate spaces on the ANSWER BOOK.
2. This question paper consists of TEN questions. Answer ALL the questions in the ANSWER BOOK.
3. Start EACH question on a NEW page in the ANSWER BOOK.
4. Number the answers correctly according to the numbering system used in this question paper.
5. Leave ONE line between two subquestions, e.g. between QUESTION 2.1 and QUESTION 2.2.
6. You may use a non-programmable calculator.
7. You may use appropriate mathematical instruments.
8. Show ALL formulae and substitutions in ALL calculations.
9. Round off your FINAL numerical answers to a minimum of TWO decimal places.
10. Give brief motivations, discussions, etc. where required.
11. You are advised to use the attached DATA SHEETS.
12. Write neatly and legibly.

QUESTION 1: MULTIPLE-CHOICE QUESTIONS

Various options are provided as possible answers to the following questions. Choose the answer and write only the letter (A–D) next to the question numbers (1.1 to 1.10) in the ANSWER BOOK, e.g. 1.11 E.

1.1 Which ONE of the following is the general formula for the alkanes?

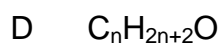

(2)

1.2 The EMPIRICAL FORMULA of hexanoic acid is ...

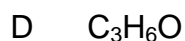
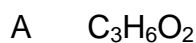

(2)

1.3 Which ONE of the following is the CORRECT structural formula for METHYL ETHANOATE?

A	$ \begin{array}{c} \text{H} \quad \text{O} \\ \quad \\ \text{H}-\text{C}-\text{C}-\text{O}-\text{H} \\ \\ \text{H}-\text{C}-\text{H} \\ \\ \text{H} \end{array} $	B	$ \begin{array}{c} \text{O} \quad \text{H} \quad \text{H} \\ \quad \quad \\ \text{H}-\text{C}-\text{O}-\text{C}-\text{C}-\text{H} \\ \quad \quad \quad \\ \quad \quad \text{H} \quad \text{H} \end{array} $
C	$ \begin{array}{c} \text{H} \quad \text{O} \quad \text{H} \\ \quad \quad \\ \text{H}-\text{C}-\text{C}-\text{O}-\text{C}-\text{H} \\ \quad \quad \\ \text{H} \quad \quad \text{H} \end{array} $	D	$ \begin{array}{c} \text{O} \quad \text{H} \quad \text{H} \\ \quad \quad \\ \text{H}-\text{C}-\text{O}-\text{C}-\text{C}-\text{H} \\ \quad \quad \quad \\ \quad \quad \text{H} \quad \text{H} \end{array} $

(2)

- 1.4 Zinc (Zn) granules react as follows with EXCESS hydrochloric acid solution, HCl(aq):

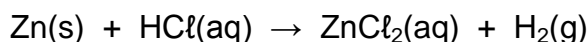

Which ONE of the following combinations of volume and concentration of HCl(aq) will result in the highest INITIAL reaction rate for the same mass of zinc granules used? (Assume that the zinc granules are completely covered by the acid in all cases.)

	VOLUME HCl(aq) (cm ³)	CONCENTRATION HCl(aq) (mol·dm ⁻³)
A	50	0,5
B	100	1,0
C	200	0,1
D	200	0,5

(2)

- 1.5 The role of a catalyst in a chemical reaction is to increase the ...

- A yield.
B activation energy.
C heat of reaction.
D rate of the reaction.

(2)

- 1.6 Consider the equilibrium represented by the balanced equation below:

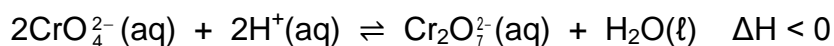

Which ONE of the following changes to the equilibrium will favour the forward reaction?

	TEMPERATURE	pH
A	Decrease	Increase
B	Decrease	Decrease
C	Increase	Increase
D	Increase	Decrease

(2)

- 1.7 The conjugate base of HPO_4^{2-} is ...

- A OH^-
B PO_4^{3-}
C H_2PO_4^-
D H_3PO_4

(2)

1.8 Which ONE of the following reactions will proceed spontaneously under standard conditions?

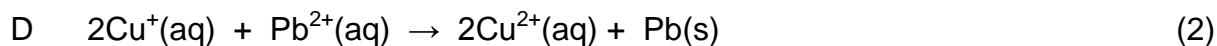
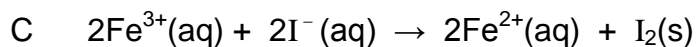
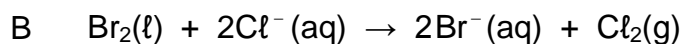
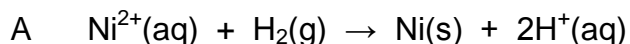

1.9 The simplified diagram below represents an electrochemical cell used for the PURIFICATION of copper.

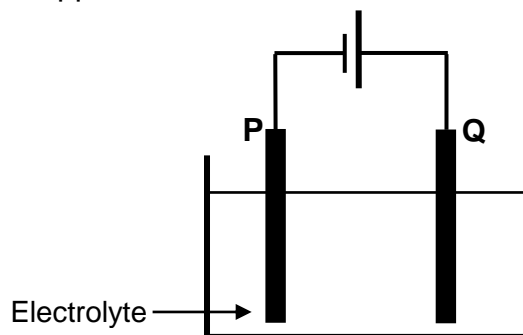

Which ONE of the graphs below represents the CHANGE IN MASS of electrodes P and Q during the purification process?

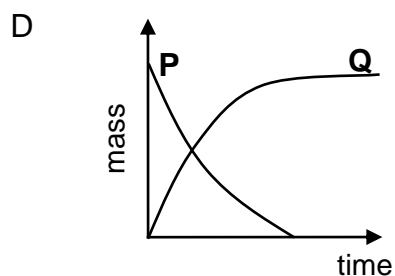
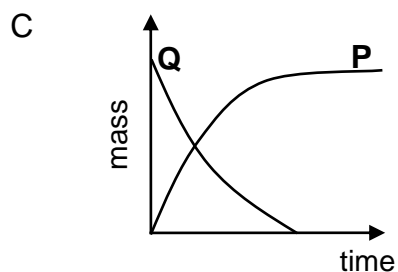
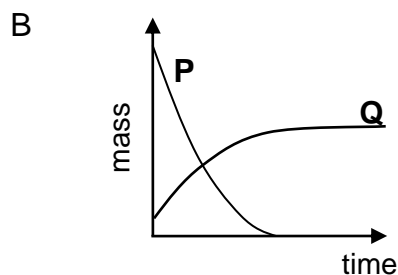
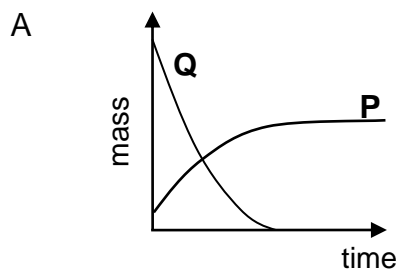

(2)

1.10 Eutrophication in water is caused by ...

A algal bloom.

B bacterial nitrogen fixation.

C an increase in plant nutrients.

D a depletion of oxygen concentration.

(2)
[20]

QUESTION 2 (Start on a new page.)

The letters **A** to **E** in the table below represent five organic compounds.

A	$ \begin{array}{cccccc} & \text{H} & \text{CH}_3 & \text{H} & \text{H} & \text{H} & \text{H} \\ & & & & & & \\ \text{H} & - \text{C} & - \text{C} & - \text{C} & - \text{C} & - \text{C} & - \text{C} - \text{H} \\ & & & & & & \\ & \text{H} & \text{H} & \text{CH}_3 & \text{H} & \text{Br} & \text{H} \end{array} $	B	$\text{C}_3\text{H}_8\text{O}$
C	$ \begin{array}{ccccccc} & \text{H} & \text{H} & \text{H} & & \text{O} & \text{H} & \text{H} & \text{H} \\ & & & & & & & & \\ \text{H} & - \text{C} & - \text{C} & - \text{C} & - \text{O} & - \text{C} & - \text{C} & - \text{C} & - \text{H} \\ & & & & & & & & \\ & \text{H} & \text{H} & \text{H} & & & \text{H} & \text{H} & \text{H} \end{array} $	D	Pentan-2-one
E	4-methylpent-2-yne		

Use the information in the table to answer the questions that follow.

2.1 For compound **D**, write down the:

2.1.1 Homologous series to which it belongs (1)

2.1.2 IUPAC name of a FUNCTIONAL ISOMER (2)

2.2 Write down the:

2.2.1 IUPAC name of compound **A** (3)

2.2.2 STRUCTURAL FORMULA of compound **E** (2)

2.3 Compound **B** is a primary alcohol.

2.3.1 Write down the meaning of the term *primary alcohol*. (2)

Compound **B** reacts with another organic compound **X** to form compound **C**.

Write down the:

2.3.2 Type of reaction that takes place (1)

2.3.3 IUPAC name of compound **X** (1)

[12]

QUESTION 3 (Start on a new page.)

The relationship between boiling point and the number of carbon atoms in straight chain molecules of aldehydes, alkanes and primary alcohols is investigated. Curves **A**, **B** and **C** are obtained.

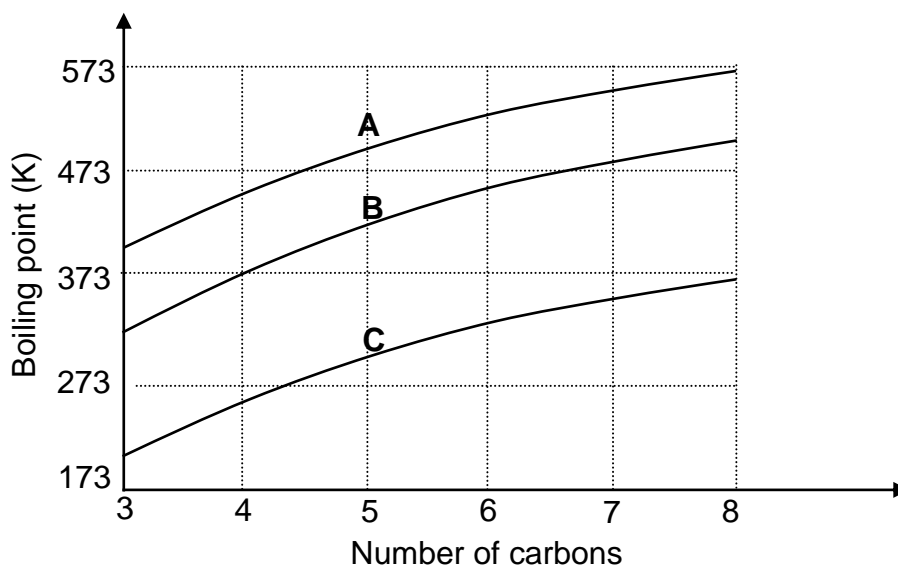

- 3.1 Define the term *boiling point*. (2)
- 3.2 Write down the STRUCTURAL FORMULA of the functional group of the aldehydes. (1)
- 3.3 The graph shows that the boiling points increase as the number of carbon atoms increases. Fully explain this trend. (3)
- 3.4 Identify the curve (**A**, **B** or **C**) that represents the following:
- 3.4.1 Compounds with London forces only (1)
- 3.4.2 The aldehydes
Explain the answer. (4)
- 3.5 Use the information in the graph and write down the IUPAC name of the compound with a boiling point of 373 K. (2)
- 3.6 Write down the IUPAC name of the compound containing five carbon atoms, which has the lowest vapour pressure at a given temperature. (2)

[15]

QUESTION 4 (Start on a new page.)

The flow diagram below shows how various organic compounds can be prepared using compound **P** as starting reagent.

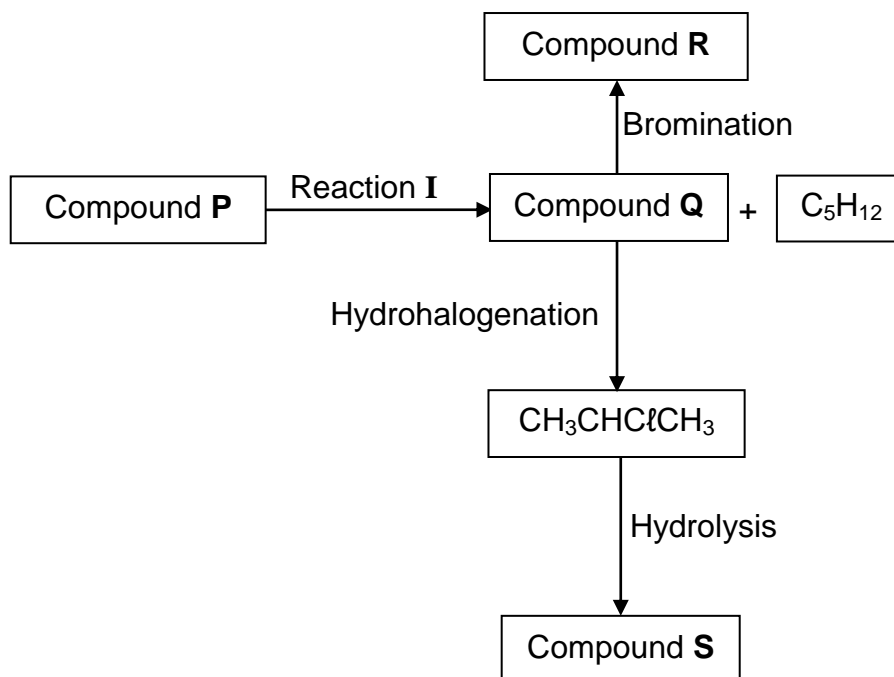

- 4.1 Write down the meaning of the term *hydrohalogenation*. (2)
- 4.2 Write down the STRUCTURAL FORMULA of compound **Q**. (2)
- 4.3 **Reaction I** is an elimination reaction.
- Write down the:
- 4.3.1 TYPE of elimination reaction (1)
- 4.3.2 MOLECULAR FORMULA of compound **P** (1)
- 4.4 Write down the IUPAC name of compound **R**. (2)
- 4.5 For the HYDROLYSIS REACTION, write down the:
- 4.5.1 Balanced equation using structural formulae (5)
- 4.5.2 TWO reaction conditions (2)
- [15]**

QUESTION 5 (Start on a new page.)

The reaction of calcium carbonate (CaCO_3) and EXCESS dilute hydrochloric acid (HCl) is used to investigate one of the factors that affects reaction rate. The balanced equation for the reaction is:



The same mass of CaCO_3 is used in all the experiments and the temperature of the hydrochloric acid in all experiments is 40°C .

The reaction conditions for each experiment are summarised in the table below.

EXPERIMENT	VOLUME OF $\text{HCl}(\text{aq})$ (cm^3)	CONCENTRATION OF $\text{HCl}(\text{aq})$ ($\text{mol}\cdot\text{dm}^{-3}$)	STATE OF DIVISION OF CaCO_3
A	500	0,1	granules
B	500	0,1	lumps
C	500	0,1	powder

5.1 For this investigation write down the:

5.1.1 Dependent variable (1)

5.1.2 Independent variable (1)

The carbon dioxide gas, $\text{CO}_2(\text{g})$, produced during EXPERIMENT A, is collected in a gas syringe. The volume of gas collected is measured every 20 s and the results obtained are shown in the graph below.

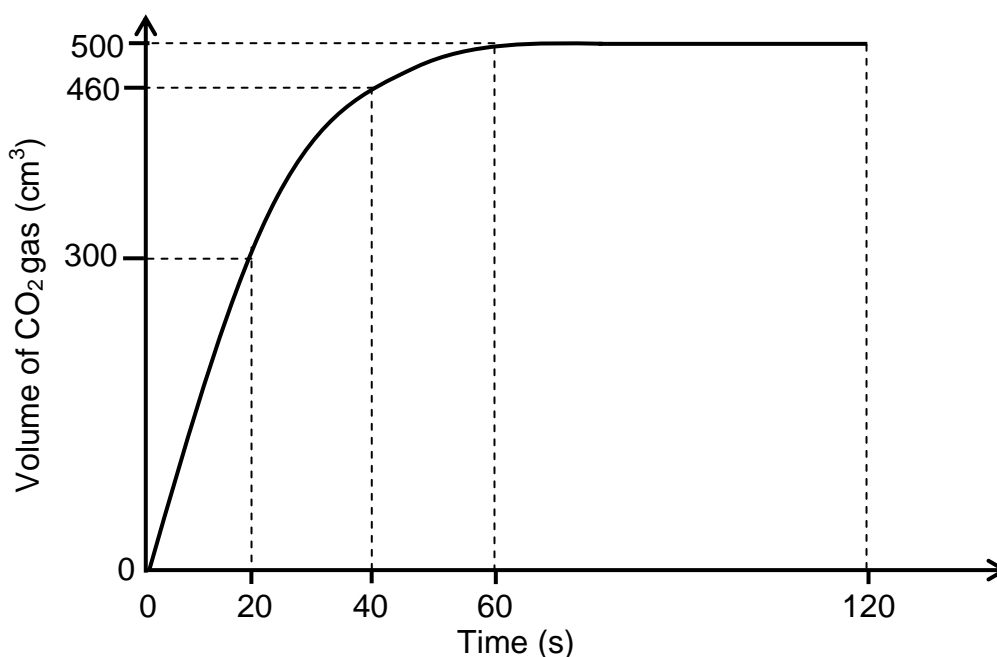

- 5.2 What can be deduced from the graph regarding the RATE OF THE REACTION during the time interval:
- 5.2.1 20 s to 40 s (1)
- 5.2.2 60 s to 120 s (1)
- 5.3 Calculate the average rate (in $\text{cm}^3 \cdot \text{s}^{-1}$) at which $\text{CO}_2(\text{g})$ is produced in the experiment. (3)
- 5.4 How will the volume of $\text{CO}_2(\text{g})$ produced in experiment **B** compare to that produced in experiment **A**? Choose from GREATER THAN, SMALLER THAN or EQUAL TO. (1)
- 5.5 A graph is now drawn for experiment **C** on the same set of axes. How will the gradient of this graph compare to the gradient of the graph for experiment **A**? Choose from GREATER THAN, SMALLER THAN or EQUAL TO. (4)
- Use the collision theory to fully explain the answer. (4)
- 5.6 Assume that the molar gas volume at $40\text{ }^\circ\text{C}$ is $25,7\text{ dm}^3 \cdot \text{mol}^{-1}$. Calculate the mass of $\text{CaCO}_3(\text{s})$ used in experiment **A**. (4)
- [16]**

QUESTION 6 (Start on a new page.)

The dissociation of iodine molecules to iodine atoms (I) is a reversible reaction taking place in a sealed container at 727 °C. The balanced equation for the reaction is:

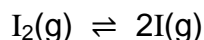

K_c for the reaction at 727 °C is $3,76 \times 10^{-3}$.

6.1 Write down the meaning of the term *reversible reaction*. (1)

6.2 At equilibrium the pressure of the system is increased by decreasing the volume of the container at constant temperature.

How will EACH of the following be affected? Choose from INCREASES, DECREASES or REMAINS THE SAME.

6.2.1 The value of the equilibrium constant (1)

6.2.2 The number of I_2 molecules (1)

6.3 Explain the answer to QUESTION 6.2.2 by referring to Le Chatelier's principle. (2)

6.4 At 227 °C, the K_c value for the reaction above is $5,6 \times 10^{-12}$.

Is the forward reaction ENDOTHERMIC or EXOTHERMIC?
Fully explain the answer. (4)

6.5 A certain mass of iodine molecules (I_2) is sealed in a $12,3 \text{ dm}^3$ flask at a temperature of 727 °C ($K_c = 3,76 \times 10^{-3}$).

When equilibrium is reached, the concentration of the iodine atoms is found to be $4,79 \times 10^{-3} \text{ mol}\cdot\text{dm}^{-3}$. Calculate the INITIAL MASS of the iodine molecules in the flask. (9)

[18]

QUESTION 7 (Start on a new page.)

- 7.1 Ethanoic acid (CH_3COOH) is an ingredient of household vinegar.
- 7.1.1 Is ethanoic acid a WEAK acid or a STRONG acid? Give a reason for the answer. (2)
- 7.1.2 An ethanoic acid solution has a pH of 3,85 at 25 °C. Calculate the concentration of the hydronium ions, $\text{H}_3\text{O}^+(\text{aq})$, in the solution. (3)
- Sodium ethanoate, $\text{CH}_3\text{COONa}(\text{aq})$, forms when ethanoic acid reacts with sodium hydroxide.
- 7.1.3 Will the pH of a sodium ethanoate solution be GREATER THAN 7, LESS THAN 7 or EQUAL TO 7? (1)
- 7.1.4 Explain the answer to QUESTION 7.1.3 with the aid of a balanced chemical equation. (3)
- 7.2 Household vinegar contains 4,52% ethanoic acid, CH_3COOH by volume.
- A 1,2 g impure sample of calcium carbonate (CaCO_3) is added to 25 cm³ household vinegar.
- On completion of the reaction, the EXCESS ethanoic acid in the household vinegar is neutralised by 14,5 cm³ of a sodium hydroxide solution of concentration 1 mol·dm⁻³. The balanced equation for the reaction is:
- $$\text{CH}_3\text{COOH}(\text{aq}) + \text{NaOH}(\text{aq}) \rightarrow \text{CH}_3\text{COONa}(\text{aq}) + \text{H}_2\text{O}(\ell)$$
- 7.2.1 Calculate the number of moles of the unreacted ethanoic acid. (3)
- 7.2.2 Calcium carbonate reacts with ethanoic acid according to the following balanced equation:
- $$\text{CaCO}_3(\text{s}) + 2\text{CH}_3\text{COOH}(\text{aq}) \rightarrow (\text{CH}_3\text{COO})_2\text{Ca}(\text{aq}) + \text{H}_2\text{O} + \text{CO}_2(\text{g})$$
- Calculate the percentage calcium carbonate in the impure sample if 1 cm³ of household vinegar has a mass of 1 g. (8)
- [20]**

QUESTION 8 (Start on a new page.)

The electrochemical cell illustrated below is set up under standard conditions.

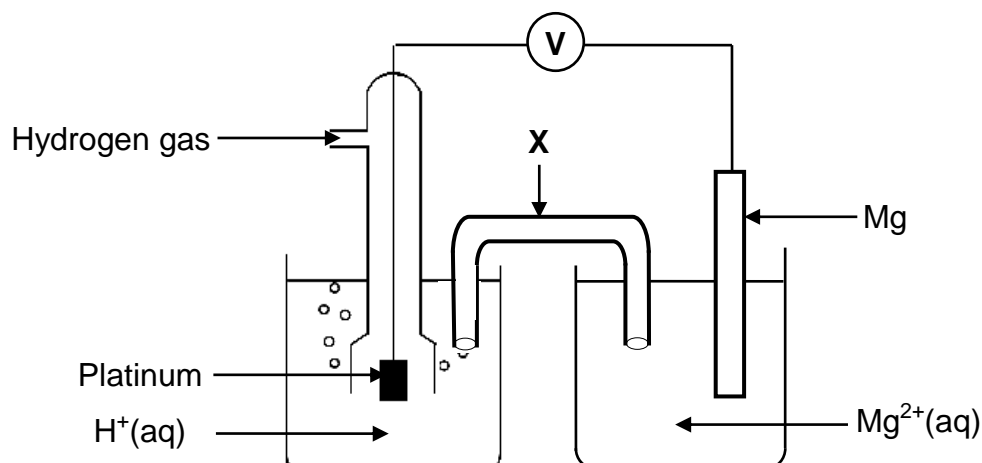

- 8.1 Component **X** completes the circuit in the cell. State ONE other function of component **X**. (1)
- 8.2 Define the term *anode*. (2)
- 8.3 Identify the anode in the cell above. (1)
- 8.4 Write down the:
- 8.4.1 Reduction half-reaction that takes place in this cell (2)
- 8.4.2 NAME or FORMULA of the reducing agent in this cell (1)
- 8.5 Calculate the initial voltmeter reading of this cell under standard conditions. (4)
- 8.6 The $\text{Mg}|\text{Mg}^{2+}$ half-cell is now replaced by a $\text{Cu}|\text{Cu}^{2+}$ half-cell. It is found that the direction of electron flow changes.
- Fully explain why there is a change in direction of electron flow by referring to the relative strengths of the reducing agents involved. (3)

[14]

QUESTION 9 (Start on a new page.)

The simplified diagram below represents an electrolytic cell used to electroplate a copper (Cu) coin with silver (Ag).

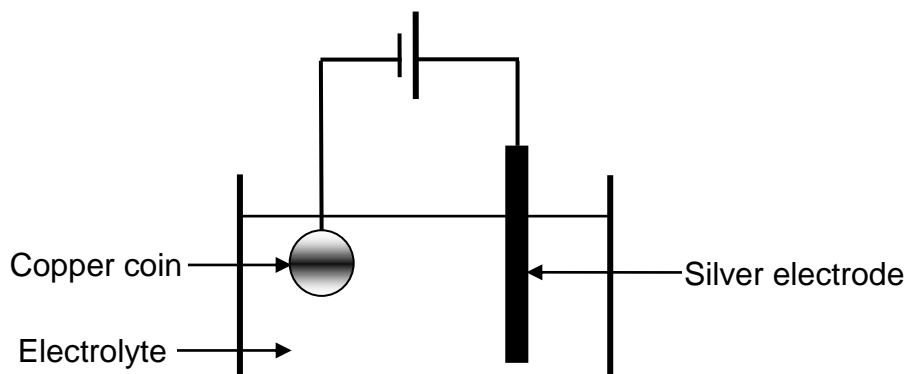

- 9.1 Define the term *electrolysis*. (2)
- 9.2 Which component in the diagram indicates that this is an electrolytic cell? (1)
- 9.3 Write down the NAME or FORMULA of the electrolyte. (1)
- 9.4 How will the concentration of the electrolyte change during electroplating?
Choose from INCREASES, DECREASES or REMAINS THE SAME. (2)
- Give a reason for the answer. (2)
- 9.5 Write down the balanced equation of the half-reaction that takes place at the silver electrode. (2)

[8]

QUESTION 10 (Start on a new page.)

10.1 The flow diagram below shows how fertiliser **B** is produced in industry.

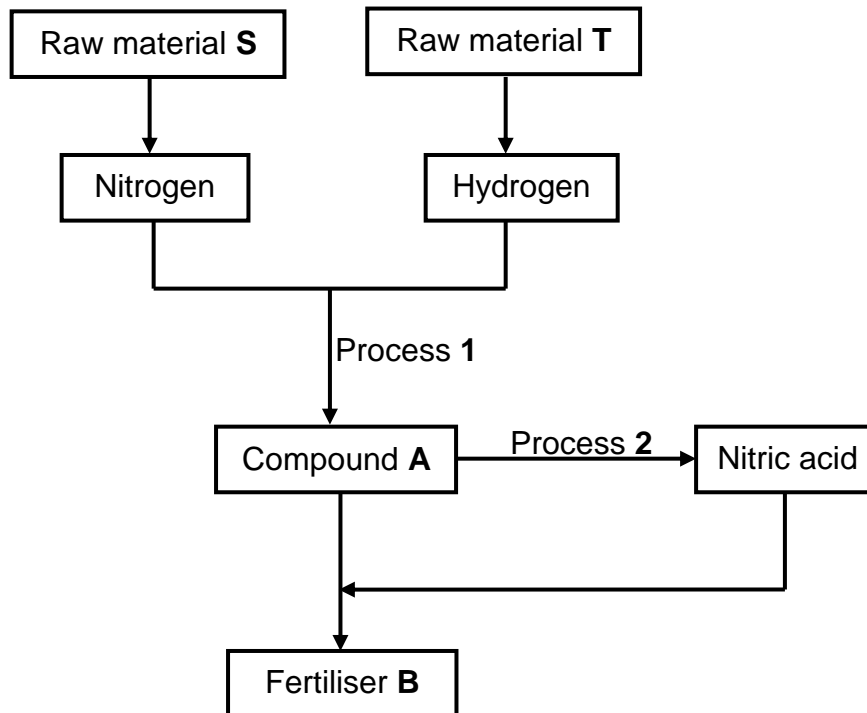

Write down the:

- 10.1.1 NAME of **S** (1)
- 10.1.2 NAME of **T** (1)
- 10.1.3 NAME or FORMULA of the catalyst used in process 1 (1)
- 10.1.4 NAME or FORMULA of compound **A** (1)
- 10.1.5 NAME of process 2 (1)
- 10.1.6 Balanced equation for the formation of fertiliser **B** (3)
- 10.2 A 20 kg bag of fertiliser is labelled as follows: **2 : 4 : 3 (X)**.
- 10.2.1 What does the ratio on the label represent? (1)
- 10.2.2 The bag contains 2,315 kg phosphorous.
Calculate the value of **X**. (3)

[12]**TOTAL: 150**

**DATA FOR PHYSICAL SCIENCES GRADE 12
PAPER 2 (CHEMISTRY)**

**GEGEWENS VIR FISIESTE WETENSKAPPE GRAAD 12
VRAESTEL 2 (CHEMIE)**

TABLE 1: PHYSICAL CONSTANTS/TABEL 1: FISIESTE KONSTANTES

NAME/NAAM	SYMBOL/SIMBOOL	VALUE/WAARDE
Standard pressure <i>Standaarddruk</i>	p^θ	$1,013 \times 10^5 \text{ Pa}$
Molar gas volume at STP <i>Molêre gasvolume by STD</i>	V_m	$22,4 \text{ dm}^3 \cdot \text{mol}^{-1}$
Standard temperature <i>Standaardtemperatuur</i>	T^θ	273 K
Charge on electron <i>Lading op elektron</i>	e	$-1,6 \times 10^{-19} \text{ C}$
Avogadro's constant <i>Avogadro-konstante</i>	N_A	$6,02 \times 10^{23} \text{ mol}^{-1}$

TABLE 2: FORMULAE/TABEL 2: FORMULES

$n = \frac{m}{M}$	$n = \frac{N}{N_A}$
$c = \frac{n}{V}$ or/of $c = \frac{m}{MV}$	$n = \frac{V}{V_m}$
$\frac{c_a v_a}{c_b v_b} = \frac{n_a}{n_b}$	$\text{pH} = -\log[\text{H}_3\text{O}^+]$
$K_w = [\text{H}_3\text{O}^+][\text{OH}^-] = 1 \times 10^{-14}$ at/by 298 K	
$E_{\text{cell}}^\theta = E_{\text{cathode}}^\theta - E_{\text{anode}}^\theta / E_{\text{sel}}^\theta = E_{\text{katode}}^\theta - E_{\text{anode}}^\theta$ or/of $E_{\text{cell}}^\theta = E_{\text{reduction}}^\theta - E_{\text{oxidation}}^\theta / E_{\text{sel}}^\theta = E_{\text{reduksie}}^\theta - E_{\text{oksidasie}}^\theta$ or/of $E_{\text{cell}}^\theta = E_{\text{oxidising agent}}^\theta - E_{\text{reducing agent}}^\theta / E_{\text{sel}}^\theta = E_{\text{oksideermiddel}}^\theta - E_{\text{reduseermiddel}}^\theta$	

TABLE 4A: STANDARD REDUCTION POTENTIALS
TABEL 4A: STANDAARD-REDUKSIEPOTENSIALE

Half-reactions/ <i>Halfreaksies</i>	E^\ominus (V)
$F_2(g) + 2e^- \rightleftharpoons 2F^-$	+ 2,87
$Co^{3+} + e^- \rightleftharpoons Co^{2+}$	+ 1,81
$H_2O_2 + 2H^+ + 2e^- \rightleftharpoons 2H_2O$	+1,77
$MnO_4^- + 8H^+ + 5e^- \rightleftharpoons Mn^{2+} + 4H_2O$	+ 1,51
$Cl_2(g) + 2e^- \rightleftharpoons 2Cl^-$	+ 1,36
$Cr_2O_7^{2-} + 14H^+ + 6e^- \rightleftharpoons 2Cr^{3+} + 7H_2O$	+ 1,33
$O_2(g) + 4H^+ + 4e^- \rightleftharpoons 2H_2O$	+ 1,23
$MnO_2 + 4H^+ + 2e^- \rightleftharpoons Mn^{2+} + 2H_2O$	+ 1,23
$Pt^{2+} + 2e^- \rightleftharpoons Pt$	+ 1,20
$Br_2(l) + 2e^- \rightleftharpoons 2Br^-$	+ 1,07
$NO_3^- + 4H^+ + 3e^- \rightleftharpoons NO(g) + 2H_2O$	+ 0,96
$Hg^{2+} + 2e^- \rightleftharpoons Hg(l)$	+ 0,85
$Ag^+ + e^- \rightleftharpoons Ag$	+ 0,80
$NO_3^- + 2H^+ + e^- \rightleftharpoons NO_2(g) + H_2O$	+ 0,80
$Fe^{3+} + e^- \rightleftharpoons Fe^{2+}$	+ 0,77
$O_2(g) + 2H^+ + 2e^- \rightleftharpoons H_2O_2$	+ 0,68
$I_2 + 2e^- \rightleftharpoons 2I^-$	+ 0,54
$Cu^+ + e^- \rightleftharpoons Cu$	+ 0,52
$SO_2 + 4H^+ + 4e^- \rightleftharpoons S + 2H_2O$	+ 0,45
$2H_2O + O_2 + 4e^- \rightleftharpoons 4OH^-$	+ 0,40
$Cu^{2+} + 2e^- \rightleftharpoons Cu$	+ 0,34
$SO_4^{2-} + 4H^+ + 2e^- \rightleftharpoons SO_2(g) + 2H_2O$	+ 0,17
$Cu^{2+} + e^- \rightleftharpoons Cu^+$	+ 0,16
$Sn^{4+} + 2e^- \rightleftharpoons Sn^{2+}$	+ 0,15
$S + 2H^+ + 2e^- \rightleftharpoons H_2S(g)$	+ 0,14
$2H^+ + 2e^- \rightleftharpoons H_2(g)$	0,00
$Fe^{3+} + 3e^- \rightleftharpoons Fe$	- 0,06
$Pb^{2+} + 2e^- \rightleftharpoons Pb$	- 0,13
$Sn^{2+} + 2e^- \rightleftharpoons Sn$	- 0,14
$Ni^{2+} + 2e^- \rightleftharpoons Ni$	- 0,27
$Co^{2+} + 2e^- \rightleftharpoons Co$	- 0,28
$Cd^{2+} + 2e^- \rightleftharpoons Cd$	- 0,40
$Cr^{3+} + e^- \rightleftharpoons Cr^{2+}$	- 0,41
$Fe^{2+} + 2e^- \rightleftharpoons Fe$	- 0,44
$Cr^{3+} + 3e^- \rightleftharpoons Cr$	- 0,74
$Zn^{2+} + 2e^- \rightleftharpoons Zn$	- 0,76
$2H_2O + 2e^- \rightleftharpoons H_2(g) + 2OH^-$	- 0,83
$Cr^{2+} + 2e^- \rightleftharpoons Cr$	- 0,91
$Mn^{2+} + 2e^- \rightleftharpoons Mn$	- 1,18
$Al^{3+} + 3e^- \rightleftharpoons Al$	- 1,66
$Mg^{2+} + 2e^- \rightleftharpoons Mg$	- 2,36
$Na^+ + e^- \rightleftharpoons Na$	- 2,71
$Ca^{2+} + 2e^- \rightleftharpoons Ca$	- 2,87
$Sr^{2+} + 2e^- \rightleftharpoons Sr$	- 2,89
$Ba^{2+} + 2e^- \rightleftharpoons Ba$	- 2,90
$Cs^+ + e^- \rightleftharpoons Cs$	- 2,92
$K^+ + e^- \rightleftharpoons K$	- 2,93
$Li^+ + e^- \rightleftharpoons Li$	- 3,05

Increasing oxidising ability/*Toenemende oksiderende vermoë*

Increasing reducing ability/*Toenemende reduserende vermoë*

TABLE 4B: STANDARD REDUCTION POTENTIALS
TABEL 4B: STANDAARD-REDUKSIEPOTENSIALE

Half-reactions/ <i>Halfreaksies</i>	E^θ (V)
$\text{Li}^+ + \text{e}^- \rightleftharpoons \text{Li}$	-3,05
$\text{K}^+ + \text{e}^- \rightleftharpoons \text{K}$	-2,93
$\text{Cs}^+ + \text{e}^- \rightleftharpoons \text{Cs}$	-2,92
$\text{Ba}^{2+} + 2\text{e}^- \rightleftharpoons \text{Ba}$	-2,90
$\text{Sr}^{2+} + 2\text{e}^- \rightleftharpoons \text{Sr}$	-2,89
$\text{Ca}^{2+} + 2\text{e}^- \rightleftharpoons \text{Ca}$	-2,87
$\text{Na}^+ + \text{e}^- \rightleftharpoons \text{Na}$	-2,71
$\text{Mg}^{2+} + 2\text{e}^- \rightleftharpoons \text{Mg}$	-2,36
$\text{Al}^{3+} + 3\text{e}^- \rightleftharpoons \text{Al}$	-1,66
$\text{Mn}^{2+} + 2\text{e}^- \rightleftharpoons \text{Mn}$	-1,18
$\text{Cr}^{2+} + 2\text{e}^- \rightleftharpoons \text{Cr}$	-0,91
$2\text{H}_2\text{O} + 2\text{e}^- \rightleftharpoons \text{H}_2(\text{g}) + 2\text{OH}^-$	-0,83
$\text{Zn}^{2+} + 2\text{e}^- \rightleftharpoons \text{Zn}$	-0,76
$\text{Cr}^{3+} + 3\text{e}^- \rightleftharpoons \text{Cr}$	-0,74
$\text{Fe}^{2+} + 2\text{e}^- \rightleftharpoons \text{Fe}$	-0,44
$\text{Cr}^{3+} + \text{e}^- \rightleftharpoons \text{Cr}^{2+}$	-0,41
$\text{Cd}^{2+} + 2\text{e}^- \rightleftharpoons \text{Cd}$	-0,40
$\text{Co}^{2+} + 2\text{e}^- \rightleftharpoons \text{Co}$	-0,28
$\text{Ni}^{2+} + 2\text{e}^- \rightleftharpoons \text{Ni}$	-0,27
$\text{Sn}^{2+} + 2\text{e}^- \rightleftharpoons \text{Sn}$	-0,14
$\text{Pb}^{2+} + 2\text{e}^- \rightleftharpoons \text{Pb}$	-0,13
$\text{Fe}^{3+} + 3\text{e}^- \rightleftharpoons \text{Fe}$	-0,06
$2\text{H}^+ + 2\text{e}^- \rightleftharpoons \text{H}_2(\text{g})$	0,00
$\text{S} + 2\text{H}^+ + 2\text{e}^- \rightleftharpoons \text{H}_2\text{S}(\text{g})$	+0,14
$\text{Sn}^{4+} + 2\text{e}^- \rightleftharpoons \text{Sn}^{2+}$	+0,15
$\text{Cu}^{2+} + \text{e}^- \rightleftharpoons \text{Cu}^+$	+0,16
$\text{SO}_4^{2-} + 4\text{H}^+ + 2\text{e}^- \rightleftharpoons \text{SO}_2(\text{g}) + 2\text{H}_2\text{O}$	+0,17
$\text{Cu}^{2+} + 2\text{e}^- \rightleftharpoons \text{Cu}$	+0,34
$2\text{H}_2\text{O} + \text{O}_2 + 4\text{e}^- \rightleftharpoons 4\text{OH}^-$	+0,40
$\text{SO}_2 + 4\text{H}^+ + 4\text{e}^- \rightleftharpoons \text{S} + 2\text{H}_2\text{O}$	+0,45
$\text{Cu}^+ + \text{e}^- \rightleftharpoons \text{Cu}$	+0,52
$\text{I}_2 + 2\text{e}^- \rightleftharpoons 2\text{I}^-$	+0,54
$\text{O}_2(\text{g}) + 2\text{H}^+ + 2\text{e}^- \rightleftharpoons \text{H}_2\text{O}_2$	+0,68
$\text{Fe}^{3+} + \text{e}^- \rightleftharpoons \text{Fe}^{2+}$	+0,77
$\text{NO}_3^- + 2\text{H}^+ + \text{e}^- \rightleftharpoons \text{NO}_2(\text{g}) + \text{H}_2\text{O}$	+0,80
$\text{Ag}^+ + \text{e}^- \rightleftharpoons \text{Ag}$	+0,80
$\text{Hg}^{2+} + 2\text{e}^- \rightleftharpoons \text{Hg}(\ell)$	+0,85
$\text{NO}_3^- + 4\text{H}^+ + 3\text{e}^- \rightleftharpoons \text{NO}(\text{g}) + 2\text{H}_2\text{O}$	+0,96
$\text{Br}_2(\ell) + 2\text{e}^- \rightleftharpoons 2\text{Br}^-$	+1,07
$\text{Pt}^{2+} + 2\text{e}^- \rightleftharpoons \text{Pt}$	+1,20
$\text{MnO}_2 + 4\text{H}^+ + 2\text{e}^- \rightleftharpoons \text{Mn}^{2+} + 2\text{H}_2\text{O}$	+1,23
$\text{O}_2(\text{g}) + 4\text{H}^+ + 4\text{e}^- \rightleftharpoons 2\text{H}_2\text{O}$	+1,23
$\text{Cr}_2\text{O}_7^{2-} + 14\text{H}^+ + 6\text{e}^- \rightleftharpoons 2\text{Cr}^{3+} + 7\text{H}_2\text{O}$	+1,33
$\text{Cl}_2(\text{g}) + 2\text{e}^- \rightleftharpoons 2\text{Cl}^-$	+1,36
$\text{MnO}_4^- + 8\text{H}^+ + 5\text{e}^- \rightleftharpoons \text{Mn}^{2+} + 4\text{H}_2\text{O}$	+1,51
$\text{H}_2\text{O}_2 + 2\text{H}^+ + 2\text{e}^- \rightleftharpoons 2\text{H}_2\text{O}$	+1,77
$\text{Co}^{3+} + \text{e}^- \rightleftharpoons \text{Co}^{2+}$	+1,81
$\text{F}_2(\text{g}) + 2\text{e}^- \rightleftharpoons 2\text{F}^-$	+2,87

Increasing oxidising ability/*Toenemende oksiderende vermoë*

Increasing reducing ability/*Toenemende reduserende vermoë*



basic education

Department:
Basic Education
REPUBLIC OF SOUTH AFRICA

**SENIOR CERTIFICATE/SENIOR SERTIFIKAAT
NATIONAL SENIOR CERTIFICATE/
NASIONALE SENIOR SERTIFIKAAT**

GRADE/GRAAD 12

**PHYSICAL SCIENCES: CHEMISTRY (P2)
FISIESE WETENSKAPPE: CHEMIE (V2)**

NOVEMBER 2020

MARKING GUIDELINES/NASIENRIGLYNE

MARKS/PUNTE: 150

**These marking guidelines consist of 17 pages./
Hierdie nasienriglyne bestaan uit 17 bladsye.**

QUESTION 1/VRAAG 1

- | | | |
|------|------|-------------|
| 1.1 | C ✓✓ | (2) |
| 1.2 | D ✓✓ | (2) |
| 1.3 | C ✓✓ | (2) |
| 1.4 | B ✓✓ | (2) |
| 1.5 | D ✓✓ | (2) |
| 1.6 | B ✓✓ | (2) |
| 1.7 | B ✓✓ | (2) |
| 1.8 | C ✓✓ | (2) |
| 1.9 | A ✓✓ | (2) |
| 1.10 | C ✓✓ | (2) |
| | | [20] |

QUESTION 2/VRAAG 2

2.1.1 Ketones/Ketone ✓ (1)

2.1.2 Pentanal/Pentanaal ✓✓

ACCEPT/AANVAAR

2,2-dimethylpropanal/2,2-dimethylpropanaal
 2-methylbutanal/2-metielbutanaal
 3-methylbutanal/3-metielbutanaal

Marking criteria/Nasienriglyne

- Correct functional group, i.e. – al / Korrekte funksionele groep d.i. al ✓
- Whole name correct/Hele naam korrek ✓

(2)

2.2.1 5 – bromo-2,3 – dimethylhexane/5 – bromo-2,3 – dimetielheksaan

Marking criteria/Nasienriglyne:

- Correct stem i.e. hexane./Korrekte stam d.i. heksaan. ✓
- All substituents (bromo and dimethyl) correctly identified./Alle substituenten (bromo en dimetiel) korrek geïdentifiseer. ✓
- IUPAC name completely correct including numbering, sequence, hyphens and commas./IUPAC-naam heeltemal korrek insluitende volgorde, koppeltekens en kommas. ✓

(3)

2.2.2

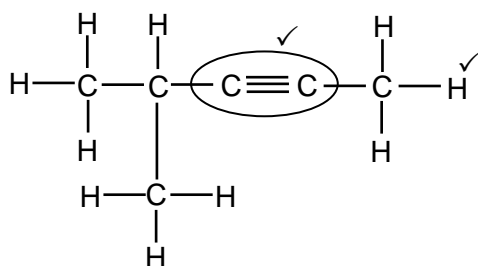

Marking criteria/Nasienriglyne

- Whole structure correct/Hele struktuur korrek: 2/2
- Only functional group correct:/Slegs funksionele groep korrek: Max/Maks.: 1/2

IF/INDIEN

More than one functional group/Meer as een funksionele groep 0/2

(2)

IF/INDIEN

Molecular formula/Molekulêre formule 0/2

Condensed structural formula /Gekondenseerde struktuurformule 1/2

- 2.3.1 The C atom bonded to the hydroxyl group is bonded to only one other C-atom. ✓✓ (2 or 0)
Die C-atoom wat aan die hidroksielgroep gebind is, is aan slegs een ander C-atoom gebind. (2 or 0)

OR/OF

The hydroxyl group/-OH/ is bonded to a C atom which is bonded to two hydrogens atoms. (2 or 0)
Die hidroksielgroep/funksionele groep is gebind aan 'n C-atoom wat aan twee waterstofatome gebind is. (2 of 0)

OR/OF

The hydroxyl group/functional group/-OH is bonded to:
a primary C atom / the first C atom (2 or 0)
Die hidroksielgroep/funksionele groep/-OH aan 'n primêre C-atoom gebind / die eerste C-atoom gebind (2 of 0)

OR/OF

The functional group $\begin{array}{c} | \\ -C - OH \\ | \end{array}$ is bonded to only one other C-atom.

Die funksionele groep $\begin{array}{c} | \\ -C - OH \\ | \end{array}$ is aan slegs een ander C-atoom gebind. (2)

- 2.3.2 Esterification/condensation ✓ (1)
Verestering/esterifikasie/kondensasie
- 2.3.3 Butanoic acid/Butanoësuur ✓ (1)
[12]

QUESTION 3/VRAAG 3

3.1

Marking criteria/Nasienriglyne

If any one of the underlined key phrases in the **correct context** is omitted, deduct 1 mark./Indien enige van die onderstreepte frases in die **korrekte konteks** uitgelaat is, trek 1 punt af.

The temperature at which the vapour pressure equals atmospheric (external) pressure. ✓✓

Die temperatuur waar die dampdruk gelyk is aan atmosferiese (eksterne) druk. (2)

3.2

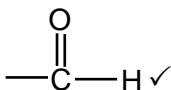

(1)

3.3

- Increase in the number of C-atoms increases molecular mass/size/chain length/surface area. ✓
- Strength of the intermolecular forces increases/More sites for London forces. ✓
- More energy is needed to overcome/break intermolecular forces. ✓
- *Toename in aantal C-atome verhoog molekulêre massa/molekulêre grootte/kettinglengte/reaksie-oppervlak*.
- *Sterkte van die intermolekulêre kragte verhoog./Meer punte vir Londonkragte.*
- *Meer energie benodig om intermolekulêre kragte te oorkom/breek*. (3)

3.4.1

C ✓

(1)

3.4.2

B ✓

Marking criteria/Nasienriglyne

- Compare strength of intermolecular forces of A, B and C. ✓
- Compare boiling points/energy required to overcome intermolecular forces of alcohols/A and aldehydes/B. ✓
- **OR**
Alcohols have the highest boiling point.
- Compare boiling points/energy required to overcome intermolecular force of aldehydes/B and alkanes/C. ✓
- **OR**
Alkanes have the lowest boiling point.
- *Vergelyk sterkte van intermolekulêre kragte van A, B en C. ✓*
- *Vergelyk kookpunte /energie benodig om intermolekulêre kragte van alkohole/A en aldehydes/B te oorkom. ✓*
- **OF**
Alkohole het die hoogste kookpunt.
- *Vergelyk kookpunte /energie benodig om intermolekulêre kragte van aldehydes/B en alkane/C. ✓*
- **OF**
Alkane het die laagste kookpunt.

Aldehydes/B have (in addition to London forces) dipole-dipole forces which are stronger than London forces, but weaker than hydrogen bonds. ✓
Therefore aldehydes/B have lower boiling points/require less energy to overcome intermolecular forces than alcohols/A, ✓ but higher boiling points / require more energy to overcome intermolecular forces than alkanes/C. ✓

Aldehyede/B het (in toevoeging tot Londonkragte) dipool-dipoolkragte wat sterker is as Londonkragte, maar swakker is as waterstofbinding.
Dus het aldehyede/B laer kookpunte/benodig minder energie om intermolekulêre kragte te oorkom as alkohole/A, maar hoër kookpunte/benodig meer energie om intermolekulêre kragte te oorkom as alkane/C.

OR/OF

Aldehydes/B have stronger intermolecular forces than alkanes, but weaker intermolecular forces than alcohols/A. ✓

Therefore aldehydes/B have higher boiling points/ more energy required to overcome intermolecular forces than alkanes/C, ✓ but lower boiling points/ less energy to overcome intermolecular forces than alcohols/A. ✓

Aldehyede/B het sterker intermolekulêre kragte as alkane/C, maar swakker intermolekulêre kragte as alkohole/A.

Dus het aldehyede/B laer kookpunte/ benodig minder energie om intermolekulêre kragte te oorkom as alkohole/A, maar hoër kookpunte/ benodig meer energie om intermolekulêre kragte te oorkom as alkane/C.

(4)

3.5 Butanal ✓✓
Butanaal

Marking criteria/Nasienriglyne

- Correct stem, i.e. but/Korrekte stam d.i. but ✓
- Whole name correct/Hele naam korrek ✓

(2)

3.6 Pentan-1-ol ✓✓
OR/OF
1-pentanol ✓✓

(2)

[15]

QUESTION 4/VRAAG 4

4.1

Marking criteria/Nasienriglyne

- Addition reaction / reaction of alkene / reaction of C – C double bond /reaction of unsaturated hydrocarbon ✓
Addisie reaksie / reaksie van 'n alkeen /reaksie van C – C dubbelbinding/reaksie van 'n onversadigde koolwaterstof.
- (Addition of) hydrogen halide/HX/ hydrogen and halide. ✓
(Addisie van) waterstofhalied/HX/waterstof en halied.

The addition ✓ of a hydrogen halide/HX ✓ to an alkene.
Die addisie van 'n waterstofhalied/HX aan 'n alkeen.

(2)

4.2

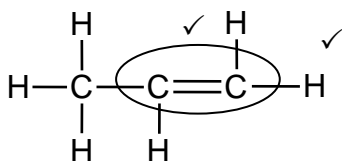

Marking criteria/Nasienriglyne

- Whole structure correct:
Hele struktuur korrek: $\frac{2}{2}$
- Only functional group correct/*Slegs funksionele groep korrek:* Max/Maks: $\frac{1}{2}$

(2)

4.3.1 Cracking/*Kraking* ✓

(1)

4.3.2 C_8H_{18} ✓

(1)

4.4 1,2-dibromo ✓ propane ✓

1,2-dibromopropaan/1,2-dibroompropaan

(2)

4.5.1

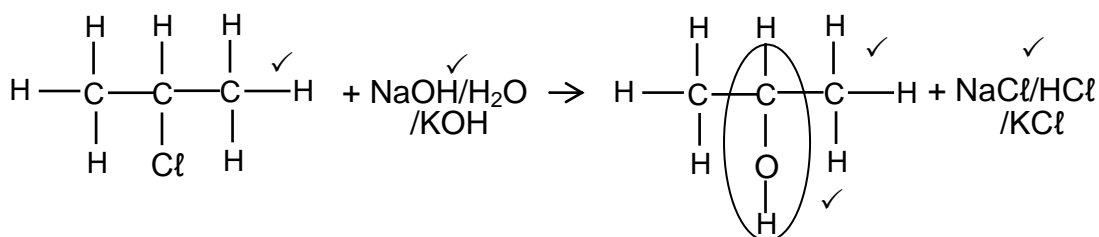

Marking criteria for the alcohol/Nasienriglyne vir die alkohol

- Whole structure of alcohol correct/*Hele struktuur van alkohol korrek:* $\frac{2}{2}$
- Only functional group correct/*Slegs funksionele groep korrek:* $\frac{1}{2}$

Notes/Aantekeninge:

- If 1-chloropropane used as reactant, 2 marks for the primary alcohol.
Indien 1-chloropropaan as reaktanse gebruik is, 2 punte vir die primêre alkohol.
- Condensed or semi-structural formula: Max. $\frac{4}{5}$
Gekondenseerde of semistruktuurformule: Maks. $\frac{4}{5}$
- Molecular formula/*Molekulêre formule:* $\frac{2}{5}$
- Any additional reactants or products: Max. $\frac{4}{5}$
Enige addisionele reaktanse of produkte: Maks. $\frac{4}{5}$
- If arrow in completely correct equation omitted: Max. $\frac{4}{5}$
Indien pyltjie in volledige korrekte vergelyking uitgelaat is: Maks. $\frac{4}{5}$
- The product NaCl/KCl/HCl must be marked in conjunction with reactant NaOH/KOH/H₂O.
Die produk NaCl/KCl/HCl moet in samehang met die reaktans NaOH/KOH / H₂O nagesien word.

(5)

4.5.2 • (Mild) heat/*(Matige) hitte* ✓

- Dilute strong base/NaOH/LiOH/KOH **OR** water/H₂O ✓
Verdunde sterk basis/NaOH/LiOH/KOH **OF** water/H₂O

(2)

[15]

QUESTION 5/VRAAG 5

- 5.1.1 (Reaction) rate/Reaksietempo ✓ (1)
- 5.1.2 Surface area/state of division /particle size ✓
Reaksie-oppervlak/toestand van verdeeldheid/deeltjie grootte (1)
- 5.2.1 (Decreasing gradient indicates) rate of reaction is decreasing. ✓
(Afnemende gradiënt dui aan dat) reaksietempo afneem. (1)
- 5.2.2 (Gradient is zero, indicates) reaction rate is zero ✓
(Gradiënt is nul, wat aandui dat) reaksietempo nul is. (1)
- 5.3
ave rate/gem tempo = $\frac{\Delta V}{\Delta t}$
= $\frac{500 \checkmark(-0)}{60 \checkmark(-0)} = 8,33 \text{ (cm}^3 \cdot \text{s}^{-1}) \checkmark$ (3)
- 5.4 Equal to/Gelyk aan ✓ (1)
- 5.5 Greater than/Groter as ✓

Experiment C/Eksperiment C:

- Surface area of CaCO₃ powder is greater than that of CaCO₃ granules./ More particles are exposed /More particles with correct orientation ✓
- More effective collisions per unit time/Higher frequency of effective collisions. ✓
- Increase in reaction rate. ✓
- Reaksieoppervlak van CaCO₃-poeier is groter (as die van CaCO₃-korrels /Meer deeltjies met korrekte oriëntasie.
- Meer effektiewe botsings per eenheid tyd./Hoër frekwensie van effektiewe botsings
- Toename in reaksie tempo

OR/OF

Experiment A/Eksperiment A:

- Surface area of CaCO₃ granules is smaller/Fewer particles are exposed (than that of powdered CaCO₃). Less particles with correct orientation ✓
- Less effective collisions per unit time./Lower frequency of effective collisions. ✓
- Decrease in reaction rate. ✓.
- Reaksieoppervlak van CaCO₃ is kleiner/Minder deeltjies is blootgestel (as die van die verpoeierde CaCO₃)./ Minder deeltjies met korrekte oriëntasie
- Minder effektiewe botsings per eenheid tyd./Laer frekwensie van effektiewe botsings.
- Afname in reaksie tempo (4)

5.6

Marking criteria/Nasienriglyne:	
<ul style="list-style-type: none"> Divide volume by 25,7 in / Deel volume deur 25,7 in $n = \frac{V}{V_M}$. ✓ If no substitution step shown, award mark for answer: 0,0195 mol <i>Indien geen vervanging stap getoon is nie, ken punt toe vit antwoord: 0,0195 mol</i> Ratio/Verhouding: $n(\text{CO}_2) = n(\text{CaCO}_3)$. ✓ Substitute/Vervang 100 in $n = \frac{m}{M}$ or in ratio / of in verhouding. ✓ Final answer/Finale antwoord: 1,95 g to/tot 2 g. ✓ 	
<p>OPTION 1/OPSIE 1</p> $n(\text{CO}_2) = \frac{V}{V_m} = \frac{0,5}{25,7} \checkmark$ $= 0,0195 \text{ mol}$ $n(\text{CaCO}_3) = n(\text{CO}_2) = 0,0195 \text{ mol} \checkmark$ $m(\text{CaCO}_3) = nM$ $= 0,0195(100)$ $= 1,95 \text{ g} \checkmark$	<p>OPTION 2/OPSIE 2</p> $25,7 \text{ dm}^3 \dots\dots\dots 1 \text{ mol}$ $0,5 \text{ dm}^3 \dots\dots\dots 0,0195 \text{ mol} \checkmark$ $100 \text{ g} \checkmark \dots\dots\dots 1 \text{ mol}$ $x \dots\dots\dots 0,0195 \text{ mol} \checkmark$ $x = m(\text{CaCO}_3) = 1,95 \text{ g} \checkmark$
<p>OPTION 3/OPSIE 3</p> $n(\text{CO}_2) = \frac{V}{V_m} = \frac{0,5}{25,7} \checkmark$ $= 0,0195 \text{ mol}$ $0,0195 \text{ mol CO}_2 \equiv 0,856 \text{ g CO}_2 \checkmark$ $m(\text{CO}_2) \text{ produced} : m(\text{CaCO}_3)$ $44 \text{ g} \quad \quad \quad : 100 \text{ g} \checkmark$ $0,856 \quad \quad \quad : x$ $x = 1,95 \text{ g} \checkmark \text{CaCO}_3$	

(4)
[16]**QUESTION 6/VRAAG 6**

- 6.1 Products can be converted back to reactants. ✓
Produkte kan omgeskakel word na reaktanse.

OR/OF

Both forward and reverse reactions can take place.
Beide voor-en terugwaartse reaksies kan plaasvind.

OR/OF

A reaction which can take place in both directions.
'n Reaksie wat in beide rigtings kan plaasvind.

(1)

- 6.2.1 Remains the same/*Bly dieselfde* ✓

(1)

- 6.2.2 Increases/*Toeneem* ✓

(1)

- 6.3
- (When pressure is increased) the reaction that leads to the smaller amount of gas / side with less molecules/number of moles is favoured. ✓
(Wanneer die druk verhoog word,) word die reaksie wat tot die kleiner hoeveelheid gas /minder gas molekule/aantal mol lei, bevoordeel.
 - The reverse reaction is favoured. ✓
Die terugwaartse reaksie word bevoordeel.

(2)

6.4 Endothermic/Endotermies ✓

- K_c decreases with decrease in temperature. ✓
- Reverse reaction is favoured. / Concentration of reactants increases. / Concentration of products decreases./Yield decreases ✓
- Decrease in temperature favours an exothermic reaction. ✓

- K_c neem af met afname in temperatuur.
- Terugwaartse reaksie word bevoordeel./Konsentrasie van reaktanse neem toe./Konsentrasie van produkte neem af./Opbrengs neem af
- Afname in temperatuur bevoordeel 'n eksotermiese reaksie.

OR/OF

- K_c increases with increase in temperature. ✓
- Forward reaction is favoured. / Concentration of reactants decreases. / Concentration of products increases./Yield increases ✓
- Increase in temperature favours an endothermic reaction. ✓

- K_c neem toename met toename in temperatuur.
- Voorwaartse reaksie word bevoordeel./Konsentrasie van produkte neem toe./Konsentrasie van reaktanse neem af./Opbrengs neem toe
- Toename in temperatuur bevoordeel 'n endotermiese reaksie

(4)

6.5

<p><u>CALCULATIONS USING NUMBER OF MOLES</u></p> <p>Mark allocation</p> <ul style="list-style-type: none">• Correct K_c expression (<u>formulae in square brackets</u>). ✓• Substitution of equilibrium concentrations into K_c expression. ✓• Substitution of K_c value. ✓• Multiply equilibrium concentrations of I_2 and I by $12,3 \text{ dm}^3$. ✓ (OPTION 1)• Multiply equilibrium concentrations of I by $12,3 \text{ dm}^3$ and divide equilibrium mol of I_2 by $12,3 \text{ dm}^3$. ✓ (OPTION 2)• Change in $n(I) = n(I \text{ at equilibrium})$. ✓• USING ratio/GEBRUIK verhouding: $I_2 : I = 1 : 2$ ✓• Initial $n(I_2) = \text{equilibrium } n(I_2) + \text{change in } n(I_2)$. ✓• Substitute $254 \text{ g} \cdot \text{mol}^{-1}$ as molar mass for I_2. ✓• Final answer: (26 g - 27,94 g). ✓ <p><u>BEREKENINGE WAT AANTAL MOL GEBRUIK</u></p> <p>Puntetoekening:</p> <ul style="list-style-type: none">• Korrekte K_c-uitdrukking (<u>formules in vierkanthakies</u>).• Vervanging van ewewigskonsentrasies in K_c-uitdrukking.• Vervanging van K_c-waarde. ✓• Vermenigvuldig ewewigskonsentrasies van I_2 en I met $12,3 \text{ dm}^3$. (OPSIE 1) Vermenigvuldig ewewigskonsentrasies van I met $12,3 \text{ dm}^3$ en deel ewewigsmol I_2 met $12,3 \text{ dm}^3$ (OPSIE 2)• Verandering in $n(I) = n(I \text{ by ewewig})$• GEBRUIK verhouding: $I_2 : I = 1 : 2$ ✓• Aanvanklike $n(I_2) = \text{ewewigs } n(I_2) + \text{verandering in } n(I_2)$.• Vervang $254 \text{ g} \cdot \text{mol}^{-1}$ as molêre massa van I_2.• Finale antwoord: (26 g – 27,94 g)
--

OPTION 1/OPSIE 1

$$K_c = \frac{[I]^2}{[I_2]} \checkmark$$

$$3,76 \times 10^{-3} = \frac{(4,79 \times 10^{-3})^2}{[I_2]} \checkmark$$

$$\therefore [I_2] = 6,102 \times 10^{-3} \text{ mol} \cdot \text{dm}^{-3}$$

	I ₂	I	
Initial mass (g) Aanvangsmassa (g)	(0,1045)(254) ✓ = 26,543 g ✓		
Initial quantity (mol) Aanvangshoeveelheid (mol)	0,1045	0	
Change (mol) Verandering (mol)	0,0295 ✓	0,0589 ✓	Using ratio ✓
Quantity at equilibrium (mol)/ Hoeveelheid by ewewig (mol)	0,0751	0,0589	
Equilibrium concentration (mol·dm ⁻³) Ewewigskonsentrasie (mol·dm ⁻³)	6,102 × 10 ⁻³	4,79 × 10 ⁻³	x12,3 ✓

No K_c expression, correct substitution/Geen K_c-uitdrukking, korrekte substitusie: Max./Maks. 8/9

Wrong K_c expression/Verkeerde K_c-uitdrukking: Max./Maks. 6/9

OPTION 2/OPSIE 2

	I ₂	I	
Initial amount (moles) Aanvangshoeveelheid (mol)	x	0	
Change in amount (moles) Verandering in hoeveelheid (mol)	0,0295 ✓	0,0589	ratio ✓ verhouding
Equilibrium amount (moles) hoeveelheid (mol)	x - 0,0295	0,0589 ✓	
Equilibrium concentration (mol·dm ⁻³) Ewewigskonsentrasie (mol·dm ⁻³)	$\frac{x - 0,0295}{12,3}$	4,79 × 10 ⁻³	x 12,3 and divide by 12,3 ✓

$$K_c = \frac{[I]^2}{[I_2]} \checkmark$$

$$3,76 \times 10^{-3} = \frac{(4,79 \times 10^{-3})^2}{\frac{x - 0,0295}{12,3}} \checkmark$$

$$x = 0,1045 \text{ mol}$$

$$\therefore m = nM \checkmark$$

$$= (0,1045)(254)$$

$$= 26,543 \text{ g} \checkmark$$

No K_c expression, correct substitution/Geen K_c-uitdrukking, korrekte substitusie: Max./Maks. 8/9

Wrong K_c expression/Verkeerde K_c-uitdrukking: Max./Maks. 6/9

CALCULATIONS USING CONCENTRATION

Mark allocation

- Correct K_c expression (formulae in square brackets). ✓
- Substitution of equilibrium concentrations into K_c expression. ✓
- Substitution of K_c value ✓
- Change in $n(I) = n(I \text{ at equilibrium})$. ✓
- **USING** ratio: $I_2 : I = 1 : 2$ ✓
- Initial $[I_2] = \text{equilibrium } [I_2] + \text{change in } [I_2]$. ✓
- Divide by $12,3 \text{ dm}^3$. ✓
- Substitute $254 \text{ g}\cdot\text{mol}^{-1}$ as molar mass for I_2 . ✓
- Final answer $26,543 \text{ g}$. ✓

BEREKENINGE WAT KONSENTRASIE GEBRUIK

Puntetoekening

- Korrekte K_c -uitdrukking (formules in vierkanthakies).
- Vervanging van ewewigskonsentrasies in K_c -uitdrukking.
- Vervanging van K_c -waarde.
- Verandering in $n(I) = n(I \text{ by ewewig})$.
- **GEBRUIK** verhouding $I_2 : I = 1 : 2$
- Aanvanklike $[I_2] = \text{ewewigs } [I_2] + \text{verandering in } [I_2]$.
- Deel deur $12,3 \text{ dm}^3$. ✓
- Vervang $254 \text{ g}\cdot\text{mol}^{-1}$ as molêre massa van I_2 .
- Finale antwoord: $26,543 \text{ g}$

OPTION 3/OPSIE 3

$$K_c = \frac{[I]^2}{[I_2]} \checkmark$$

$$3,76 \times 10^{-3} \checkmark = \frac{(4,79 \times 10^{-3})^2}{[I_2]} \checkmark$$

$$[I_2] = 6,102 \times 10^{-3} \text{ mol}\cdot\text{dm}^{-3}$$

No K_c expression, correct substitution/Geen K_c -uitdrukking, korrekte substitusie: Max./Maks. $\frac{8}{9}$

Wrong K_c expression/Verkeerde K_c -uitdrukking: Max./Maks. $\frac{6}{9}$

	I_2	I
Initial concentration ($\text{mol}\cdot\text{dm}^{-3}$) <i>Aanvangskonsentrasie ($\text{mol}\cdot\text{dm}^{-3}$)</i>	$8,497 \times 10^{-3}$	0
Change ($\text{mol}\cdot\text{dm}^{-3}$) <i>Verandering ($\text{mol}\cdot\text{dm}^{-3}$)</i>	$2,395 \times 10^{-3}$	$4,79 \times 10^{-3} \checkmark$
Equilibrium concentration ($\text{mol}\cdot\text{dm}^{-3}$) <i>Ewewigskonsentrasie ($\text{mol}\cdot\text{dm}^{-3}$)</i>	$6,102 \times 10^{-3}$	$4,79 \times 10^{-3}$

Using ratio ✓

$$c = \frac{m}{MV}$$

$$8,497 \times 10^{-3} = \frac{m}{(254) \checkmark (12,3) \checkmark}$$

$$\therefore m = 26,546 \text{ g}$$

(9)
[18]

QUESTION 7/VRAAG 7

7.1.1 Weak/Swak ✓



Ionises/Dissociates incompletely/partially (in water) ✓
 Ioniseer/Dissosieer/onvolledig/gedeeltelik (in water)

(2)

7.1.2

OPTION 1/OPSIE 1	OPTION 2/OPSIE 2
$\text{pH} = -\log[\text{H}_3\text{O}^+] \checkmark$ $3,85 \checkmark = -\log[\text{H}_3\text{O}^+]$ $[\text{H}_3\text{O}^+] = 1,41 \times 10^{-4} \text{ mol}\cdot\text{dm}^{-3} \checkmark$	$[\text{H}_3\text{O}^+] = 10^{-\text{pH}} \checkmark$ $= 10^{-3,85} \checkmark$ $= 1,41 \times 10^{-4} \text{ mol}\cdot\text{dm}^{-3} \checkmark$

(3)

7.1.3 Greater than/Groter as ✓

(1)

7.1.4 $\text{CH}_3\text{COO}^-(\text{aq}) + \text{H}_2\text{O}(\ell) \checkmark \rightleftharpoons \text{CH}_3\text{COOH}(\text{aq}) + \text{OH}^-(\text{aq}) \checkmark$

OR/OF

$\text{CH}_3\text{COONa}(\text{aq}) + \text{H}_2\text{O}(\ell) \checkmark \rightleftharpoons \text{CH}_3\text{COOH}(\text{aq}) + \text{NaOH}(\text{aq}) \checkmark$

Due to formation of hydroxide/ OH^- / the solution is basic/alkaline / $\text{pH} > 7$. ✓

As gevolg van die vorming van hidoksied/ OH^- is die oplossing basies/
 alkalies / $\text{pH} > 7$

(3)

7.2.1

Marking criteria/Nasienriglyne

- Substitute/vervang: 1 x 0,0145 **OR/OF** 1 x 14,5 in $c = \frac{n}{V} / \frac{c_a \times V_a}{c_b \times V_b} = \frac{n_a}{n_b}$. ✓
- Use/Gebruik: $n(\text{CH}_3\text{COOH}) : n(\text{NaOH}) = 1:1 \checkmark$
- Final answer/Finale antwoord: 0,0145 mol ✓

OPTION 1/OPSIE 1

$$\begin{aligned} n(\text{NaOH})_{\text{reacted}} &= cV \\ &= 1(0,0145) \checkmark \\ &= 0,0145 \text{ mol} \end{aligned}$$

$$\begin{aligned} n(\text{CH}_3\text{COOH})_{\text{diluted}} &= n(\text{NaOH}) \checkmark \\ &= 0,0145 \text{ mol} \checkmark \end{aligned}$$

(3)

7.2.2 **POSITIVE MARKING FROM 7.2.1./POSITIEWE NASIEN VANAF VRAAG 7.2.1.**

Marking criteria/Nasienriglyne

- Calculate mass/Bereken massa CH_3COOH in 25 cm^3 (1,13 g). ✓
- Formula/Formule: $n = \frac{m}{M}$. ✓
- Substitute/Vervang: $M = 60 \text{ g}\cdot\text{mol}^{-1}$. ✓
- $n(\text{CH}_3\text{COOH})_{\text{reacted/reageer}} = n_{\text{initial/begin}} - n_{\text{unreacted/nie reageer}}$ ✓
- USE mol ratio/GEbruik molverhouding: $n(\text{CaCO}_3) : n(\text{CH}_3\text{COOH}) = 1 : 2$. ✓
- Substitution of/Vervanging van $100 \text{ g}\cdot\text{mol}^{-1}$ in $m = nM$. ✓
- Calculate percentage/Bereken persentasie: $\frac{0,217}{1,2} \times 100$ ✓
- Final answer/Finale antwoord: 18,08% ✓ (17,92 – 22,92)

$$m(\text{CH}_3\text{COOH}) = \frac{4,52}{100} \times 25 \checkmark = 1,13 \text{ g}$$

$$n(\text{CH}_3\text{COOH})_{\text{ini/aanv.}} = \frac{m}{M} \checkmark$$

$$= \frac{1,13}{60} \checkmark = 0,01883 \text{ mol}$$

$$n(\text{CH}_3\text{COOH})_{\text{rea}} = 0,01883 \checkmark - 0,0145 = 0,0043 \text{ mol}$$

$$n(\text{CaCO}_3) = \frac{1}{2} n(\text{CH}_3\text{COOH})$$

$$= 0,5(0,0043) \checkmark$$

$$= 0,00217 \text{ mol}$$

$$m(\text{CaCO}_3) = nM \checkmark$$

$$= 0,00217(100) = 0,217 \text{ g}$$

$$\% \text{ CaCO}_3 = \frac{0,217}{1,2} \times 100 \checkmark$$

$$= 18,08 \% \checkmark$$

(8)
[20]

QUESTION 8/VRAAG 8

- 8.1 Provides path for movement of ions./Ensures(electrical)neutrality in the cell. ✓
Verskaf pad vir beweging van ione./Verseker (elektriese) neutraliteit in die sel. (1)
- 8.2 (The electrode) where oxidation takes place/electrons are lost. ✓✓
(Die elektrode) waar oksidasie plaasvind/elektrone verloor word. (2)
- 8.3 Mg/Magnesium ✓ (1)
- 8.4.1 $2\text{H}^+ + 2\text{e}^- \rightarrow \text{H}_2$ ✓✓

Marking criteria/Nasienriglyne	
$\text{H}_2 \leftarrow 2\text{H}^+ + 2\text{e}^- \quad (2/2)$	$2\text{H}^+ + 2\text{e}^- \rightleftharpoons \text{H}_2 \quad (1/2)$
$\text{H}_2 \rightleftharpoons 2\text{H}^+ + 2\text{e}^- \quad (0/2)$	$2\text{H}^+ + 2\text{e}^- \leftarrow \text{H}_2 \quad (0/2)$
<ul style="list-style-type: none"> • Ignore if charge omitted on electron./<i>Ignoreer indien lading weggelaat op elektron.</i> • If charge (+) omitted on H^+/Indien lading (+) weggelaat op H^+: 	
Example/Voorbeeld: $2\text{H}^+ + 2\text{e}^- \rightarrow \text{H}_2$ ✓	Max./Maks: $1/2$

- 8.4.2 Magnesium/Mg ✓ (1)

<p>OPTION 1/OPSIE 1</p> $E_{\text{cell}}^{\theta} = E_{\text{reduction}}^{\theta} - E_{\text{oxidation}}^{\theta} \checkmark$ $= 0 \checkmark - (-2,36) \checkmark$ $E_{\text{cell}}^{\theta} = 2,36 \text{ V} \checkmark$	<p>Notes/Aantekeninge</p> <ul style="list-style-type: none"> • Accept any other correct formula from the data sheet./<i>Aanvaar enige ander korrekte formule vanaf gegewensblad.</i> • Any other formula using unconventional abbreviations, e.g. $E_{\text{cell}}^{\theta} = E_{\text{OA}}^{\theta} - E_{\text{RA}}^{\theta}$ followed by correct substitutions./<i>Enige ander formule wat onkonvensionele afkortings gebruik bv. $E_{\text{sel}}^{\theta} = E_{\text{OM}}^{\theta} - E_{\text{RM}}^{\theta}$ gevolg deur korrekte vervangings: $3/4$</i> 						
<p>OPTION 2/OPSIE 2</p> <table style="width: 100%; border-collapse: collapse;"> <tr> <td style="width: 50%;">$\checkmark 2\text{H}^+ + 2\text{e}^- \rightarrow \text{H}_2$</td> <td style="width: 50%;">$E^{\theta} = 0 \text{ V} \checkmark$</td> </tr> <tr> <td style="border-bottom: 1px solid black;">$\text{Mg(s)} \rightarrow \text{Mg}^{2+}(\text{aq}) + 2\text{e}^-$</td> <td style="border-bottom: 1px solid black;">$E^{\theta} = +2,36 \text{ V} \checkmark$</td> </tr> <tr> <td>$\text{Mg(s)} + 2\text{H}^+(\text{aq}) \rightarrow \text{Mg}^{2+}(\text{aq}) + \text{H}_2(\text{g})$</td> <td>$E^{\theta} = +2,36 \text{ V} \checkmark$</td> </tr> </table>		$\checkmark 2\text{H}^+ + 2\text{e}^- \rightarrow \text{H}_2$	$E^{\theta} = 0 \text{ V} \checkmark$	$\text{Mg(s)} \rightarrow \text{Mg}^{2+}(\text{aq}) + 2\text{e}^-$	$E^{\theta} = +2,36 \text{ V} \checkmark$	$\text{Mg(s)} + 2\text{H}^+(\text{aq}) \rightarrow \text{Mg}^{2+}(\text{aq}) + \text{H}_2(\text{g})$	$E^{\theta} = +2,36 \text{ V} \checkmark$
$\checkmark 2\text{H}^+ + 2\text{e}^- \rightarrow \text{H}_2$	$E^{\theta} = 0 \text{ V} \checkmark$						
$\text{Mg(s)} \rightarrow \text{Mg}^{2+}(\text{aq}) + 2\text{e}^-$	$E^{\theta} = +2,36 \text{ V} \checkmark$						
$\text{Mg(s)} + 2\text{H}^+(\text{aq}) \rightarrow \text{Mg}^{2+}(\text{aq}) + \text{H}_2(\text{g})$	$E^{\theta} = +2,36 \text{ V} \checkmark$						

- 8.6 H_2 is a stronger reducing agent ✓ than Cu ✓ and therefore Cu^{2+}/Cu ions are reduced/ H_2 is oxidised ✓ Electrons flow from H_2 to Cu. (3)
- H_2 is 'n sterker reduseermiddel as Cu en dus word Cu^{2+}/Cu -ione gereduseer/ H_2 is geoksideer. Elektrone vloei vanaf H_2 na Cu. (3)

[14]

QUESTION 9/VRAAG 9

9.1 ANY ONE/ENIGE EEN:

- The chemical process in which electrical energy is converted to chemical energy. ✓✓ (2 or 0)
- The use of electrical energy to produce a chemical change. (2 or 0)
- Decomposition of an ionic compound by means of electrical energy. (2 or 0)
- The process during which and electric current passes through a solution/ionic liquid/molten ionic compound. (2 or 0)
- *Die chemiese proses waarin elektriese energie omgeskakel word na chemiese energie. (2 of 0)*
- *Die gebruik van elektriese energie om 'n chemiese verandering te weeg te bring. (2 of 0)*
- *Ontbinding van 'n ioniese verbinding met behulp van elektriese energie. (2 of 0)*
- *Die proses waardeur 'n elektriese stroom deur 'n oplossing/ioniese vloeistof/gesmelte ioniese verbinding beweeg. (2 of 0)* (2)

9.2 Battery/cell/ power source ✓
Battery/sel/kragbron (1)

9.3 Silver nitrate/AgNO₃/ Silver ethanoate/CH₃COOAg / Silver fluoride /AgF/
Silver perchlorate AgClO₄. ✓
*Silwernitraat/AgNO₃/ Silweretanoaat/CH₃COOAg / Silwerfloried / AgF /
Silwerperchloraat / AgClO₄* (1)

9.4  Remains the same/*Bly dieselfde* ✓
Rate of oxidation is equal to the rate of reduction. ✓
Tempo van oksidasie is gelyk aan die tempo van reduksie. (2)

9.5 $\text{Ag} \rightarrow \text{Ag}^+ + \text{e}^-$ ✓✓

Notes/Aantekeninge

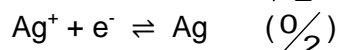
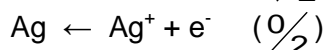
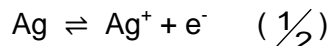
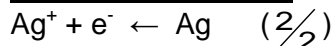

- Ignore if charge omitted on electron./*Ignoreer indien lading weggelaat op elektron.*

- If charge (+) omitted on Ag⁺/*Indien lading (+) weggelaat op Ag⁺:*

Example/*Voorbeeld:* $\text{Ag} \rightarrow \text{Ag} + \text{e}^-$ ✓

(2)
[8]

QUESTION 10/VRAAG 10

- 10.1.1 (Liquid) Air/(Vloeibare)Lug ✓ (1)
- 10.1.2 Natural gas/methane/oil/coal/coke✓
 Aardgas/metaan/olie/steenkool/kooks (1)
- 10.1.3 Iron/iron oxide/Fe/FeO ✓
 Yster/ysteroksied/Fe/FeO (1)
- 10.1.4 NH₃/Ammonia/Ammoniak ✓ (1)
- 10.1.5 Ostwald (process)/Ostwald(proses) ✓ (1)
- 10.1.6 NH₃ + HNO₃ ✓ → NH₄NO₃ ✓ Bal ✓

Marking criteria/Nasienriglyne

- Reactants ✓ Products ✓ Balancing ✓
 Reaktanse Produkte Balansering
- Ignore double arrows./Ignoreer dubbelpyle.
- Marking rule 6.3.10./Nasienreël 6.3.10.

(3)

- 10.2.1 NPK ratio/Ratio of primary nutrients ✓
 NPK-verhouding/Verhouding van primêre voedingstowwe (1)

<p>OPTION 1/OPSIE 1</p> $\frac{4}{9} \times \frac{X}{100} \times 20 = 2,315 \text{ kg}$ <p>X = 26 ✓ (26,04)</p>	<p>OPTION 2/OPSIE 2</p> <p>m(P) = 2,315 kg</p> <p>Mass of 1 part P = $\frac{2,315}{4} = 0,57575$</p> <p>Mass of N = (0,57575)(2) = 1,1575 kg</p> <p>Mass of K = (0,57575)(3) = 1,73625 kg</p> <p>Total mass of fertiliser: 1,1575 + 2,315 + 1,73625 = 5,20875 kg ✓</p> <p>X = $\frac{5,20875}{20} \times 100 = 26,04$ ✓</p>
--	---

(3)

[12]

TOTAL/TOTAAL: 150