



basic education

Department:
Basic Education
REPUBLIC OF SOUTH AFRICA

**NATIONAL
SENIOR CERTIFICATE**

GRADE 12

PHYSICAL SCIENCES: CHEMISTRY (P2)

NOVEMBER 2017

MARKS: 150

TIME: 3 hours

This question paper consists of 16 pages and 4 data sheets.

INSTRUCTIONS AND INFORMATION

1. Write your centre number and examination number in the appropriate spaces on the ANSWER BOOK.
2. This question paper consists of TEN questions. Answer ALL the questions in the ANSWER BOOK.
3. Start EACH question on a NEW page in the ANSWER BOOK.
4. Number the answers correctly according to the numbering system used in this question paper.
5. Leave ONE line between two subquestions, for example between QUESTION 2.1 and QUESTION 2.2.
6. You may use a non-programmable calculator.
7. You may use appropriate mathematical instruments.
8. You are advised to use the attached DATA SHEETS.
9. Show ALL formulae and substitutions in ALL calculations.
10. Round off your FINAL numerical answers to a minimum of TWO decimal places.
11. Give brief motivations, discussions, et cetera where required.
12. Write neatly and legibly.

QUESTION 1: MULTIPLE-CHOICE QUESTIONS

Various options are provided as possible answers to the following questions. Choose the answer and write only the letter (A–D) next to the question number (1.1–1.10) in the ANSWER BOOK, for example 1.11 D.

1.1 The IUPAC name of an organic compound with molecular formula $C_7H_{14}O_2$:

A Heptanal

B Heptan-1-ol

C Heptan-2-ol

D Heptanoic acid

(2)

1.2 Which ONE of the following structures is the functional group of aldehydes?

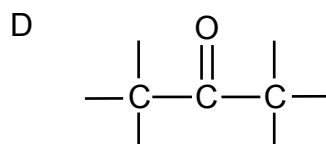
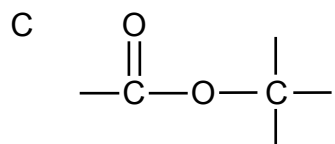
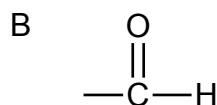
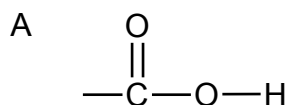

(2)

1.3 Which ONE of the following equations represents a cracking process?

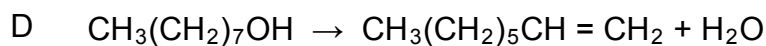
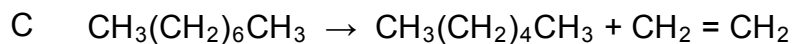
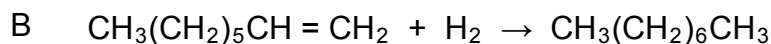
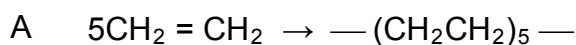

(2)

1.4 The potential energy diagram for a chemical reaction is shown below.

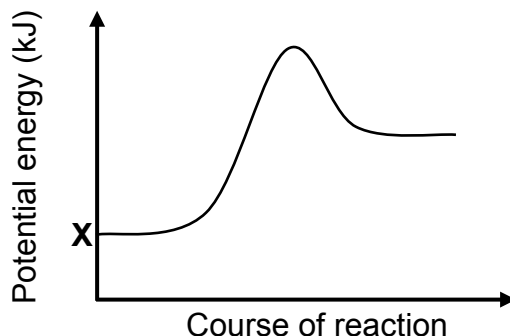

Consider the following statements regarding the graph above:

- I:** X represents the potential energy of the products formed during the reverse reaction.
- II:** The graph could be a representation of the change in potential energy for the following reaction:

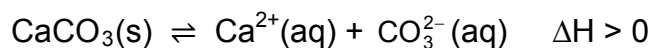

- III:** The graph could be a representation of the change in potential energy for the combustion of methane.

Which of the statements above are TRUE?

- A I and II only
- B II and III only
- C I and III only
- D I, II and III

(2)

1.5 A certain chemical reaction reaches equilibrium at 25 °C. The equilibrium constant, K_c , for the reaction at this temperature is $1,0 \times 10^{-4}$.

Which ONE of the following statements regarding this reaction at equilibrium is CORRECT?

- A The concentration of the products is equal to that of the reactants.
- B The concentration of the products is higher than that of the reactants.
- C The concentration of the products is lower than that of the reactants.
- D The rate of the forward reaction is lower than the rate of the reverse reaction.

(2)

- 1.6 Consider the following chemical reaction at equilibrium in a closed container:

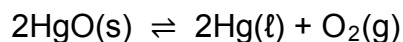

More HgO(s) is now added to the container at constant temperature.

How will the number (in moles) of O₂(g) and the value of K_c be affected at equilibrium?

	NUMBER OF MOLES OF O ₂	K _c
A	Increases	Increases
B	Increases	Remains the same
C	Remains the same	Remains the same
D	Remains the same	Increases

(2)

- 1.7 Which ONE of the following solutions, each of concentration 0,1 mol·dm⁻³, has the highest pH?

- A HNO₃(aq)
 B NH₄Cl(aq)
 C Na₂CO₃(aq)
 D CH₃COOH(aq)

(2)

- 1.8 The cell notation for a galvanic cell is as follows:



Which ONE of the following statements is CORRECT for this cell?

- A Ni is oxidised.
 B Pb(s) is reduced.
 C Ni²⁺(aq) is the oxidising agent.
 D Pb²⁺ is the reducing agent.

(2)

- 1.9 Which ONE of the following combinations CORRECTLY shows the products formed during the electrolysis of a CONCENTRATED sodium chloride solution?

	CATHODE	ANODE
A	Hydrogen	Sodium
B	Hydrogen	Chlorine
C	Chlorine	Sodium
D	Chlorine	Hydrogen

(2)

- 1.10 Which ONE of the following is NOT part of the eutrophication process?

- A Algal bloom
- B Bacterial nitrogen fixation
- C Depletion of oxygen in water
- D Increase in plant nutrients in water

(2)
[20]

QUESTION 2 (Start on a new page.)

2.1 Study the structural formula below.

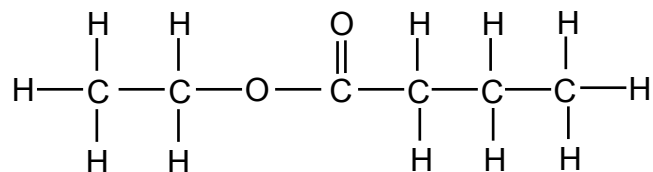

For this compound, write down the:

- 2.1.1 Homologous series to which it belongs (1)
- 2.1.2 IUPAC name (2)
- 2.1.3 IUPAC name of the organic acid used in its preparation (1)
- 2.1.4 STRUCTURAL FORMULA of its straight chain (unbranched) functional isomer (2)
- 2.2 Write down the structural formula of 4-methylpentan-2-one. (3)
- 2.3 Consider the structural formula below.

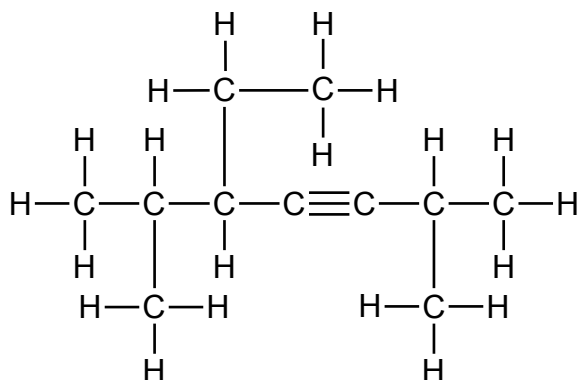

For this compound, write down the:

- 2.3.1 General formula of the homologous series to which it belongs (1)
- 2.3.2 IUPAC name (3)
- [13]**

QUESTION 3 (Start on a new page.)

The vapour pressure versus temperature graph below was obtained for four straight chain (unbranched) alkanes (**P**, **Q**, **R** and **S**).

FROM **P** TO **S**, EACH COMPOUND DIFFERS FROM THE PREVIOUS COMPOUND BY A $-\text{CH}_2$ GROUP.

The vapour pressures are measured in mmHg. Atmospheric pressure is 760 mmHg.

Graph of vapour pressure versus temperature

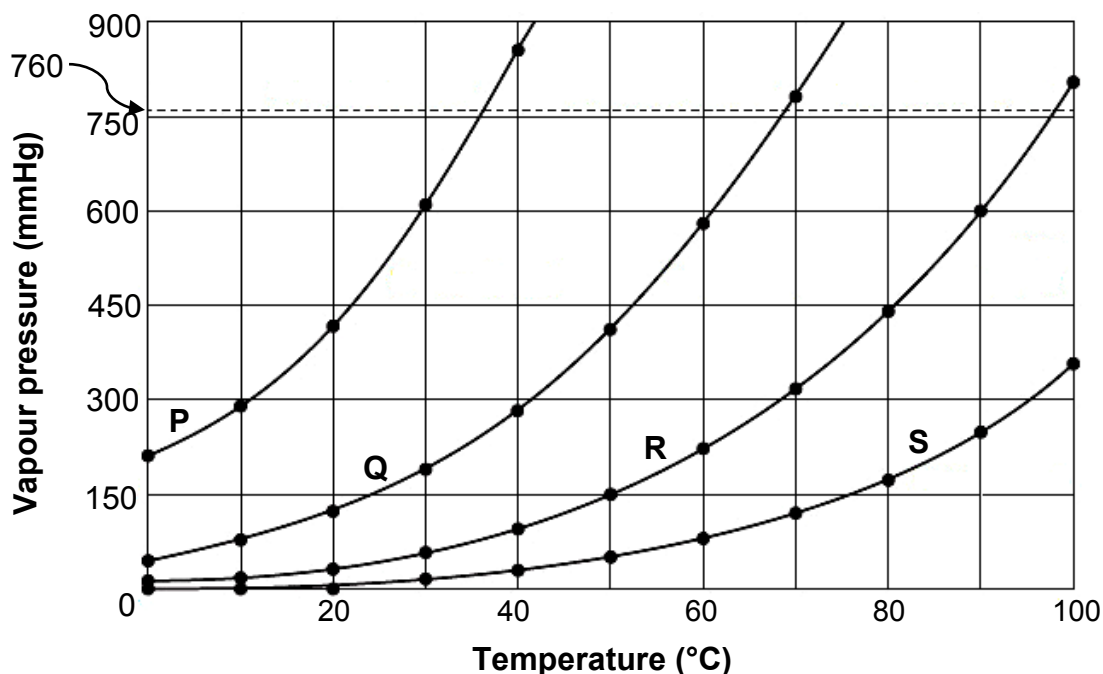

- 3.1 Give a reason why alkanes are said to be SATURATED. (1)
- 3.2 Define *vapour pressure*. (2)
- 3.3 Use the information in the graph above to answer the following questions.
- 3.3.1 What is the effect of an increase in temperature on vapour pressure? Choose from INCREASES, DECREASES or NO EFFECT. (1)
- 3.3.2 Which compound has a boiling point of approximately 68 °C? Give a reason for the answer. (2)
- 3.3.3 Which compound has the longest chain length? Fully explain the answer. (4)
- 3.4 Compound **P** has FIVE carbon atoms.
- 3.4.1 Draw the structural formula of a chain isomer of **P**. Write down the IUPAC name of this isomer. (3)
- 3.4.2 How will the vapour pressure of this isomer compare with that of compound **P**? Choose from HIGHER THAN, LOWER THAN or EQUAL TO. (1)

[14]

QUESTION 4 (Start on a new page.)

The flow diagram below shows how an alcohol (compound **P**) can be used to prepare other organic compounds. The letters **A** to **E** represent different organic reactions. **X**, **Y** and **Z** are organic compounds.

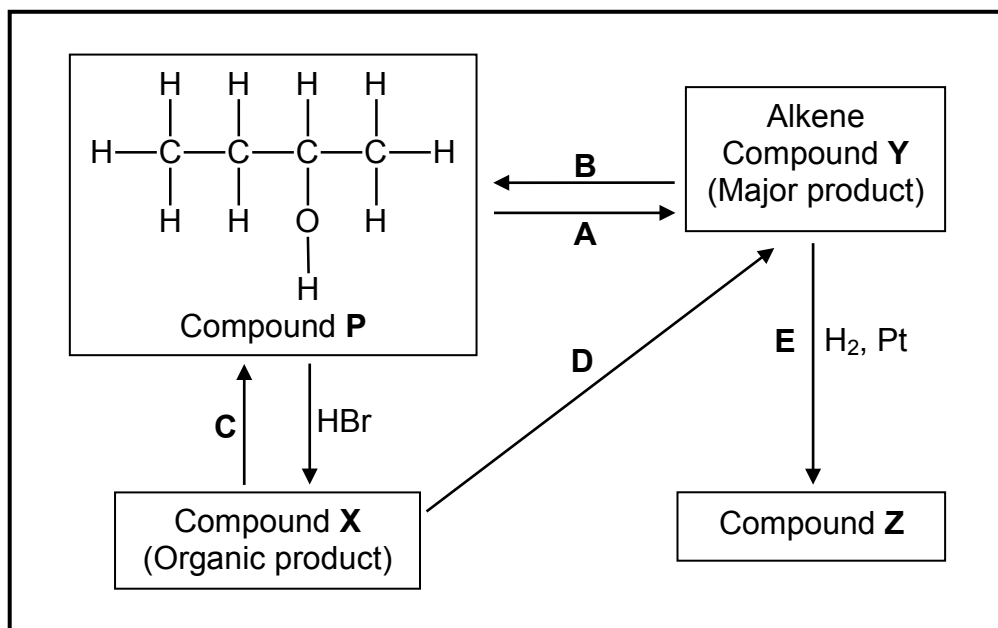

- 4.1 Is compound **P** a PRIMARY, SECONDARY or TERTIARY alcohol? Give a reason for the answer. (2)
- 4.2 Write down the type of:
- 4.2.1 Elimination reaction represented by **A** (1)
- 4.2.2 Addition reaction represented by **B** (1)
- 4.2.3 Elimination reaction represented by **D** (1)
- 4.3 Sodium hydroxide is used as one of the reactants in reaction **C**.
- 4.3.1 What type of reaction takes place here? (1)
- 4.3.2 State the TWO reaction conditions for this reaction. (2)
- 4.3.3 Write down the IUPAC name of compound **X**. (2)
- 4.4 Write down the FORMULA of an inorganic reactant needed for reaction **D**. (1)
- 4.5 Using STRUCTURAL FORMULAE, write down a balanced equation for reaction **E**. (3)
- 4.6 Write down the IUPAC name of compound **Z**. (1)

[15]

QUESTION 5 (Start on a new page.)

A group of learners uses the reaction between powdered zinc and EXCESS dilute hydrochloric acid to investigate one of the factors that affects the rate of a chemical reaction. The balanced equation for the reaction is:

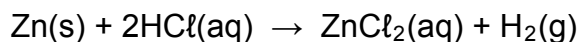

They conduct two experiments. The reaction conditions used are summarised in the table below.

EXPERIMENT	TEMPERATURE (°C)	VOLUME OF HCl (cm ³)	CONCENTRATION OF HCl (mol·dm ⁻³)	MASS OF Zn (g)
I	25	200	0,25	x
II	25	200	0,40	x

The results obtained are shown in the graph (not drawn to scale) below.

Graph of volume of H₂(g) produced versus time

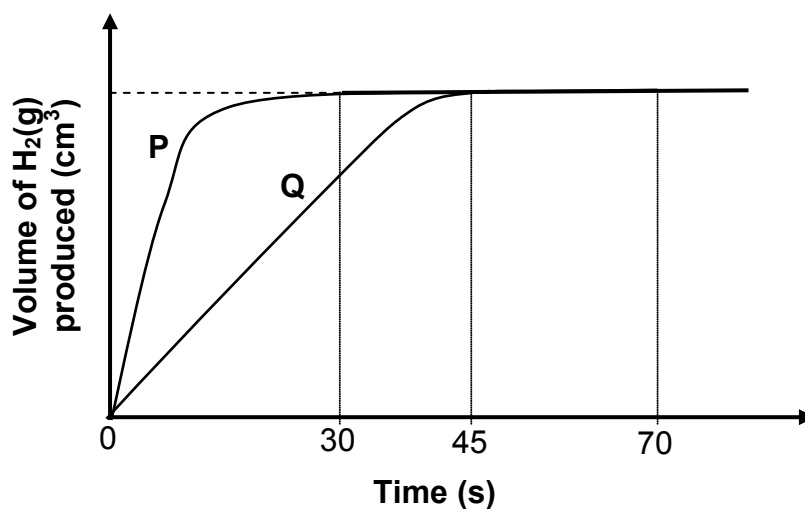

- 5.1 Define *reaction rate*. (2)
- 5.2 Write down an investigative question for this investigation. (2)
- 5.3 Which curve, **P** or **Q**, represents the results of experiment I? Explain the answer. (3)
- 5.4 The average rate of the production of hydrogen gas, as represented by graph **P**, was $15 \text{ cm}^3 \cdot \text{s}^{-1}$. Calculate the mass of zinc used. **Take the molar gas volume at 25 °C as 24 000 cm³.** (5)

- 5.5 In a third experiment (experiment **III**), 200 cm³ of a 0,25 mol·dm⁻³ dilute hydrochloric acid solution at 35 °C reacts with the same amount of zinc powder as in experiment **I** and experiment **II**.
- 5.5.1 How will the heat of reaction of experiment **II** compare with that of experiment **III**? Choose from MORE THAN, LESS THAN or EQUAL TO. (1)
- 5.5.2 How will the activation energy of the reaction in experiment **I** compare with that of the reaction in experiment **III**? Choose from MORE THAN, LESS THAN or EQUAL TO. (1)
- 5.6 The rate of the reaction in experiment **III** is higher than that of experiment **I**.
Fully explain this statement by referring to the collision theory. (3)
[17]

QUESTION 6 (Start on a new page.)

Carbonyl bromide, COBr₂, decomposes into carbon monoxide and bromine according to the following balanced equation:

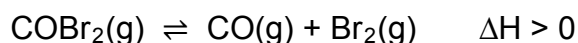

Initially COBr₂(g) is sealed in a 2 dm³ container and heated to 73 °C. The reaction is allowed to reach equilibrium at this temperature. The equilibrium constant for the reaction at this temperature is 0,19.

- 6.1 Define *chemical equilibrium*. (2)

At equilibrium it is found that 1,12 g CO(g) is present in the container.

- 6.2 Calculate the:
- 6.2.1 Equilibrium concentration of the COBr₂(g) (7)
- 6.2.2 Percentage of COBr₂(g) that decomposed at 73 °C (4)
- 6.3 Which ONE of the following CORRECTLY describes the K_c value when equilibrium is reached at a lower temperature?

$K_c < 0,19$	$K_c > 0,19$	$K_c = 0,19$
--------------	--------------	--------------

(1)

- 6.4 The pressure of the system is now decreased by increasing the volume of the container at 73 °C and the system is allowed to reach equilibrium.

How will the number of moles of COBr₂(g) be affected? Choose from INCREASES, DECREASES or REMAINS THE SAME. Explain the answer. (3)

[17]

QUESTION 7 (Start on a new page.)

- 7.1 Ammonia ionises in water to form a basic solution according to the following balanced equation:

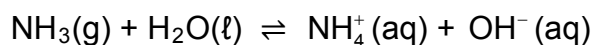

- 7.1.1 Is ammonia a WEAK or a STRONG base? Give a reason for the answer. (2)
- 7.1.2 Write down the conjugate acid of $\text{NH}_3(\text{g})$. (1)
- 7.1.3 Identify ONE substance in this reaction that can behave as an ampholyte in some reactions. (1)
- 7.2 A learner adds distilled water to a soil sample and then filters the mixture. The pH of the filtered liquid is then measured.

He then gradually adds an ammonia solution, $\text{NH}_3(\text{aq})$, to this liquid and measures the pH of the solution at regular intervals. The graph below shows the results obtained.

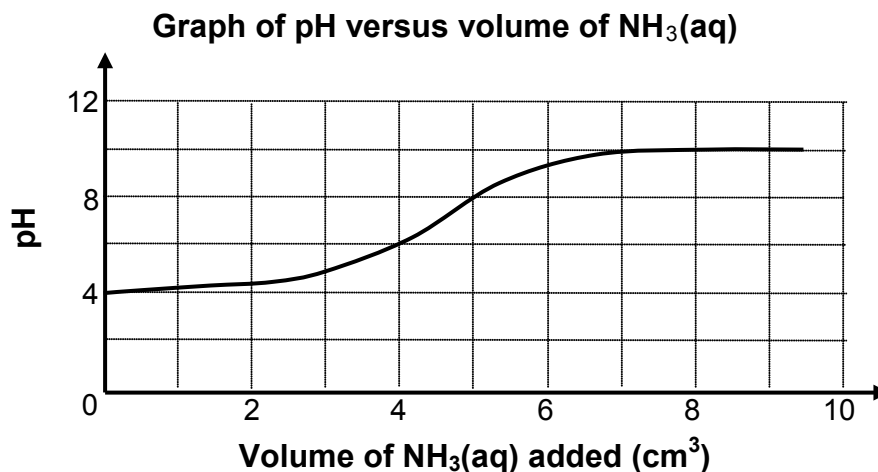

- 7.2.1 Is the soil sample ACIDIC or BASIC? Refer to the graph above and give a reason for the answer. (2)
- 7.2.2 Calculate the concentration of the hydroxide ions (OH^-) in the reaction mixture after the addition of 4 cm^3 of $\text{NH}_3(\text{aq})$. (4)

- 7.3 A laboratory technician wants to determine the concentration of a hydrochloric acid (HCl) sample. He adds 5 cm³ of the HCl sample to 495 cm³ of distilled water to give 500 cm³ of dilute hydrochloric acid, HCl(aq).

During a reaction 50 cm³ of this dilute hydrochloric acid solution, HCl(aq), reacts completely with 0,29 g of sodium carbonate, Na₂CO₃(s).

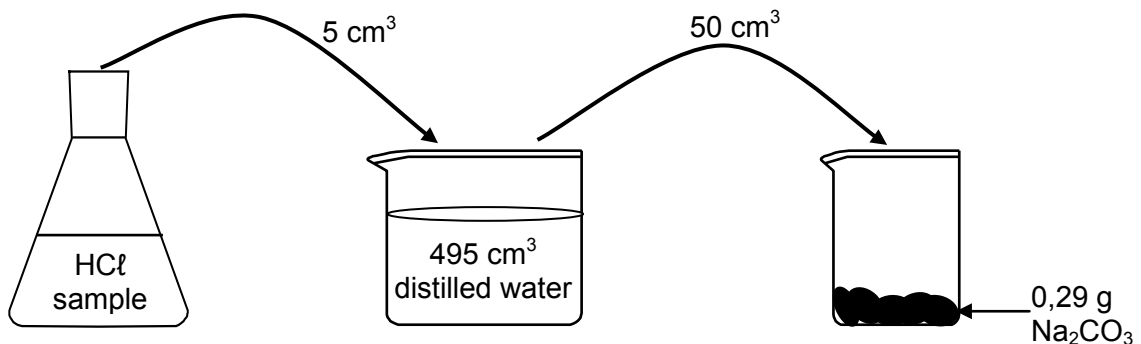

The balanced equation for the reaction is:

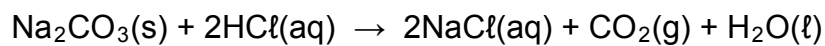

Calculate the concentration of the hydrochloric acid sample.

(7)
[17]

QUESTION 8 (Start on a new page.)

- 8.1 Learners set up a galvanic cell and measure its emf under standard conditions.

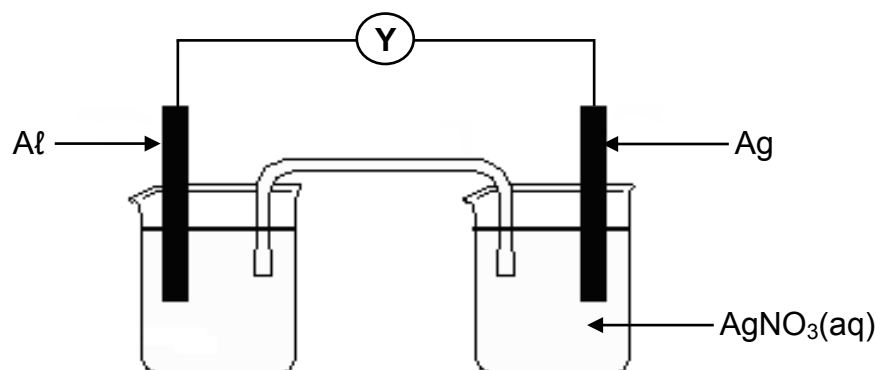

- 8.1.1 Write down the name of component Y. (1)
- 8.1.2 Is Al the ANODE or the CATHODE? (1)
- 8.1.3 Write down the overall (net) cell reaction that takes place in this cell when it is working. (3)
- 8.1.4 Calculate the initial emf of this cell. (4)

8.2 Consider the half-cells, **P**, **Q** and **R**, represented in the table below.

HALF-CELL		
P	Q	R
Zn Zn ²⁺ (aq)	Cl ₂ Cl ⁻ (aq)	Cu Cu ²⁺ (aq)

Different combinations of the half-cells above are compared to determine the highest emf produced under standard conditions.

- 8.2.1 Write down the NAME of a suitable electrode for half-cell **Q**. (1)
- 8.2.2 State the standard conditions under which the half-cells should operate to ensure a fair comparison. (2)
- 8.2.3 Write down the NAME or FORMULA of the strongest reducing agent in the half-cells above. (1)
- 8.2.4 Which combination of half-cells will produce the highest emf? Choose from **PR**, **PQ** or **QR**. (NO calculation is required.) (1)
- [14]**

QUESTION 9 (Start on a new page.)

The simplified diagram below represents an electrochemical cell used in the refining of copper. One of the electrodes consists of impure copper.

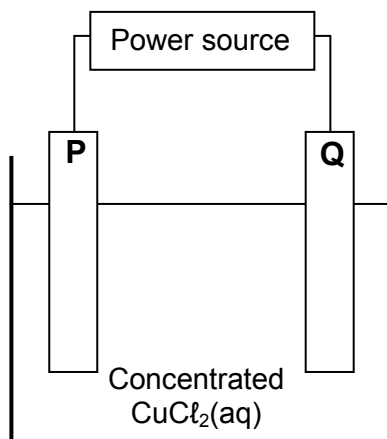

- 9.1 What type of power source, AC or DC, is used to drive the reaction in this cell? (1)
- 9.2 When an electric current passes through the $\text{CuCl}_2(\text{aq})$, the mass of electrode **P** increases.
Is electrode **P** the CATHODE or the ANODE?
Write down the relevant half-reaction to support the answer. (3)
- 9.3 The impure copper contains zinc impurities which are oxidised to zinc ions.
Refer to the relative strengths of oxidising agents to explain why zinc ions will not influence the quality of the pure copper produced in this cell. (3)
- 9.4 Electrodes **P** and **Q** are now replaced by carbon electrodes.
- 9.4.1 What will be observed at electrode **Q**? (1)
- 9.4.2 How will the concentration of the electrolyte change as the reaction proceeds? Choose from INCREASES, DECREASES or REMAINS THE SAME. (1)

[9]

QUESTION 10 (Start on a new page.)

- 10.1 The equations below represent two industrial processes involved in the preparation of ammonium nitrate.

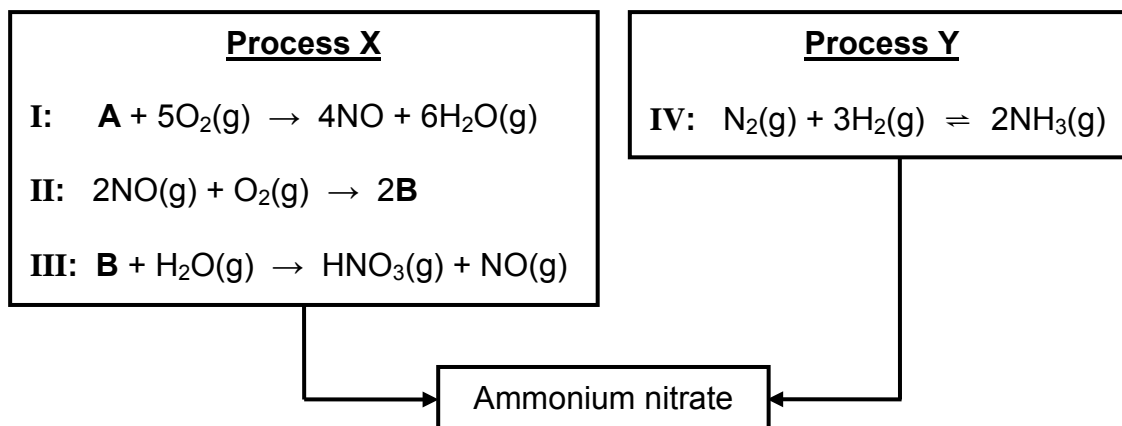

Write down the:

- 10.1.1 NAME of substance **A** (1)
- 10.1.2 FORMULA of substance **B** (1)
- 10.1.3 NAME given for reaction **I** (1)
- 10.1.4 NAME or FORMULA of the catalyst used in reaction **I** (1)
- 10.1.5 Name of process **X** (1)
- 10.1.6 Name of process **Y** (1)
- 10.1.7 Balanced equation for the preparation of ammonium nitrate from the products obtained in process **X** and process **Y** (3)
- 10.2 A 15 kg bag of fertiliser contains 5% phosphorus, 10% nitrogen and 15% potassium.
- Calculate the:
- 10.2.1 Mass of phosphorus in the bag (2)
- 10.2.2 Mass of filler in the bag (3)

[14]**TOTAL: 150**

**DATA FOR PHYSICAL SCIENCES GRADE 12
PAPER 2 (CHEMISTRY)**

**GEGEWENS VIR FISIESTE WETENSAPPE GRAAD 12
VRAESTEL 2 (CHEMIE)**

TABLE 1: PHYSICAL CONSTANTS/TABEL 1: FISIESTE KONSTANTES

NAME/NAAM	SYMBOL/SIMBOOL	VALUE/WAARDE
Standard pressure <i>Standaarddruk</i>	p^θ	$1,013 \times 10^5 \text{ Pa}$
Molar gas volume at STP <i>Molêre gasvolume by STD</i>	V_m	$22,4 \text{ dm}^3 \cdot \text{mol}^{-1}$
Standard temperature <i>Standaardtemperatuur</i>	T^θ	273 K
Charge on electron <i>Lading op elektron</i>	e	$-1,6 \times 10^{-19} \text{ C}$
Avogadro's constant <i>Avogadro-konstante</i>	N_A	$6,02 \times 10^{23} \text{ mol}^{-1}$

TABLE 2: FORMULAE/TABEL 2: FORMULES

$n = \frac{m}{M}$	$n = \frac{N}{N_A}$
$c = \frac{n}{V}$ or/of $c = \frac{m}{MV}$	$n = \frac{V}{V_m}$
$\frac{c_a V_a}{c_b V_b} = \frac{n_a}{n_b}$	$\text{pH} = -\log[\text{H}_3\text{O}^+]$
$K_w = [\text{H}_3\text{O}^+][\text{OH}^-] = 1 \times 10^{-14}$ at/by 298 K	
$E_{\text{cell}}^\theta = E_{\text{cathode}}^\theta - E_{\text{anode}}^\theta$ / $E_{\text{sel}}^\theta = E_{\text{katode}}^\theta - E_{\text{anode}}^\theta$ or/of $E_{\text{cell}}^\theta = E_{\text{reduction}}^\theta - E_{\text{oxidation}}^\theta$ / $E_{\text{sel}}^\theta = E_{\text{reduksie}}^\theta - E_{\text{oksidasie}}^\theta$ or/of $E_{\text{cell}}^\theta = E_{\text{oxidising agent}}^\theta - E_{\text{reducing agent}}^\theta$ / $E_{\text{sel}}^\theta = E_{\text{oksideermiddel}}^\theta - E_{\text{reduseermiddel}}^\theta$	

TABLE 3: THE PERIODIC TABLE OF ELEMENTS
TABEL 3: DIE PERIODIEKE TABEL VAN ELEMENTE

1 (I)	2 (II)	3	4	5	6	7	8	9	10	11	12	13 (III)	14 (IV)	15 (V)	16 (VI)	17 (VII)	18 (VIII)
1 2,1 H																	2 4 He
3 1,0 Li	4 1,5 Be											5 2,0 B	6 2,5 C	7 3,0 N	8 3,5 O	9 4,0 F	10 20 Ne
11 0,9 Na	12 1,2 Mg											13 1,5 Al	14 1,8 Si	15 2,1 P	16 2,5 S	17 3,0 Cl	18 40 Ar
19 0,8 K	20 1,0 Ca	21 1,3 Sc	22 1,5 Ti	23 1,6 V	24 1,6 Cr	25 1,5 Mn	26 1,8 Fe	27 1,8 Co	28 1,8 Ni	29 1,9 Cu	30 1,6 Zn	31 1,6 Ga	32 1,8 Ge	33 2,0 As	34 2,4 Se	35 2,8 Br	36 84 Kr
37 0,8 Rb	38 1,0 Sr	39 1,2 Y	40 1,4 Zr	41 1,6 Nb	42 1,8 Mo	43 1,9 Tc	44 2,2 Ru	45 2,2 Rh	46 2,2 Pd	47 1,9 Ag	48 1,7 Cd	49 1,7 In	50 1,8 Sn	51 1,9 Sb	52 2,1 Te	53 2,5 I	54 131 Xe
55 0,7 Cs	56 0,9 Ba	57 139 La	72 1,6 Hf	73 181 Ta	74 184 W	75 186 Re	76 190 Os	77 192 Ir	78 195 Pt	79 197 Au	80 201 Hg	81 1,8 Tl	82 1,8 Pb	83 1,9 Bi	84 2,0 Po	85 2,5 At	86 209 Rn
87 0,7 Fr	88 0,9 Ra	89 Ac															
			58 Ce	59 Pr	60 Nd	61 Pm	62 Sm	63 Eu	64 Gd	65 Tb	66 Dy	67 Ho	68 Er	69 Tm	70 Yb	71 Lu	
			90 Th	91 Pa	92 U	93 Np	94 Pu	95 Am	96 Cm	97 Bk	98 Cf	99 Es	100 Fm	101 Md	102 No	103 Lr	

KEY/SLEUTEL

Atomic number
Atoomgetal

Electronegativity
Elektronegatiwiteit

Symbol
Simbool

29 Cu 63,5

Approximate relative atomic mass
Benaderde relatiewe atoommassa

TABLE 4A: STANDARD REDUCTION POTENTIALS
TABEL 4A: STANDAARD-REDUKSIEPOTENSIALE

Half-reactions/ <i>Halfreaksies</i>	E^{\ominus} (V)
$F_2(g) + 2e^- \rightleftharpoons 2F^-$	+ 2,87
$Co^{3+} + e^- \rightleftharpoons Co^{2+}$	+ 1,81
$H_2O_2 + 2H^+ + 2e^- \rightleftharpoons 2H_2O$	+1,77
$MnO_4^- + 8H^+ + 5e^- \rightleftharpoons Mn^{2+} + 4H_2O$	+ 1,51
$Cl_2(g) + 2e^- \rightleftharpoons 2Cl^-$	+ 1,36
$Cr_2O_7^{2-} + 14H^+ + 6e^- \rightleftharpoons 2Cr^{3+} + 7H_2O$	+ 1,33
$O_2(g) + 4H^+ + 4e^- \rightleftharpoons 2H_2O$	+ 1,23
$MnO_2 + 4H^+ + 2e^- \rightleftharpoons Mn^{2+} + 2H_2O$	+ 1,23
$Pt^{2+} + 2e^- \rightleftharpoons Pt$	+ 1,20
$Br_2(l) + 2e^- \rightleftharpoons 2Br^-$	+ 1,07
$NO_3^- + 4H^+ + 3e^- \rightleftharpoons NO(g) + 2H_2O$	+ 0,96
$Hg^{2+} + 2e^- \rightleftharpoons Hg(l)$	+ 0,85
$Ag^+ + e^- \rightleftharpoons Ag$	+ 0,80
$NO_3^- + 2H^+ + e^- \rightleftharpoons NO_2(g) + H_2O$	+ 0,80
$Fe^{3+} + e^- \rightleftharpoons Fe^{2+}$	+ 0,77
$O_2(g) + 2H^+ + 2e^- \rightleftharpoons H_2O_2$	+ 0,68
$I_2 + 2e^- \rightleftharpoons 2I^-$	+ 0,54
$Cu^+ + e^- \rightleftharpoons Cu$	+ 0,52
$SO_2 + 4H^+ + 4e^- \rightleftharpoons S + 2H_2O$	+ 0,45
$2H_2O + O_2 + 4e^- \rightleftharpoons 4OH^-$	+ 0,40
$Cu^{2+} + 2e^- \rightleftharpoons Cu$	+ 0,34
$SO_4^{2-} + 4H^+ + 2e^- \rightleftharpoons SO_2(g) + 2H_2O$	+ 0,17
$Cu^{2+} + e^- \rightleftharpoons Cu^+$	+ 0,16
$Sn^{4+} + 2e^- \rightleftharpoons Sn^{2+}$	+ 0,15
$S + 2H^+ + 2e^- \rightleftharpoons H_2S(g)$	+ 0,14
$2H^+ + 2e^- \rightleftharpoons H_2(g)$	0,00
$Fe^{3+} + 3e^- \rightleftharpoons Fe$	- 0,06
$Pb^{2+} + 2e^- \rightleftharpoons Pb$	- 0,13
$Sn^{2+} + 2e^- \rightleftharpoons Sn$	- 0,14
$Ni^{2+} + 2e^- \rightleftharpoons Ni$	- 0,27
$Co^{2+} + 2e^- \rightleftharpoons Co$	- 0,28
$Cd^{2+} + 2e^- \rightleftharpoons Cd$	- 0,40
$Cr^{3+} + e^- \rightleftharpoons Cr^{2+}$	- 0,41
$Fe^{2+} + 2e^- \rightleftharpoons Fe$	- 0,44
$Cr^{3+} + 3e^- \rightleftharpoons Cr$	- 0,74
$Zn^{2+} + 2e^- \rightleftharpoons Zn$	- 0,76
$2H_2O + 2e^- \rightleftharpoons H_2(g) + 2OH^-$	- 0,83
$Cr^{2+} + 2e^- \rightleftharpoons Cr$	- 0,91
$Mn^{2+} + 2e^- \rightleftharpoons Mn$	- 1,18
$Al^{3+} + 3e^- \rightleftharpoons Al$	- 1,66
$Mg^{2+} + 2e^- \rightleftharpoons Mg$	- 2,36
$Na^+ + e^- \rightleftharpoons Na$	- 2,71
$Ca^{2+} + 2e^- \rightleftharpoons Ca$	- 2,87
$Sr^{2+} + 2e^- \rightleftharpoons Sr$	- 2,89
$Ba^{2+} + 2e^- \rightleftharpoons Ba$	- 2,90
$Cs^+ + e^- \rightleftharpoons Cs$	- 2,92
$K^+ + e^- \rightleftharpoons K$	- 2,93
$Li^+ + e^- \rightleftharpoons Li$	- 3,05

Increasing oxidising ability/*Toenemende oksiderende vermoë*

Increasing reducing ability/*Toenemende reduserende vermoë*

TABLE 4B: STANDARD REDUCTION POTENTIALS
TABEL 4B: STANDAARD-REDUKSIEPOTENSIALE

Half-reactions/ <i>Halfreaksies</i>	E^{\ominus} (V)
$\text{Li}^+ + e^- \rightleftharpoons \text{Li}$	-3,05
$\text{K}^+ + e^- \rightleftharpoons \text{K}$	-2,93
$\text{Cs}^+ + e^- \rightleftharpoons \text{Cs}$	-2,92
$\text{Ba}^{2+} + 2e^- \rightleftharpoons \text{Ba}$	-2,90
$\text{Sr}^{2+} + 2e^- \rightleftharpoons \text{Sr}$	-2,89
$\text{Ca}^{2+} + 2e^- \rightleftharpoons \text{Ca}$	-2,87
$\text{Na}^+ + e^- \rightleftharpoons \text{Na}$	-2,71
$\text{Mg}^{2+} + 2e^- \rightleftharpoons \text{Mg}$	-2,36
$\text{Al}^{3+} + 3e^- \rightleftharpoons \text{Al}$	-1,66
$\text{Mn}^{2+} + 2e^- \rightleftharpoons \text{Mn}$	-1,18
$\text{Cr}^{2+} + 2e^- \rightleftharpoons \text{Cr}$	-0,91
$2\text{H}_2\text{O} + 2e^- \rightleftharpoons \text{H}_2(\text{g}) + 2\text{OH}^-$	-0,83
$\text{Zn}^{2+} + 2e^- \rightleftharpoons \text{Zn}$	-0,76
$\text{Cr}^{3+} + 3e^- \rightleftharpoons \text{Cr}$	-0,74
$\text{Fe}^{2+} + 2e^- \rightleftharpoons \text{Fe}$	-0,44
$\text{Cr}^{3+} + e^- \rightleftharpoons \text{Cr}^{2+}$	-0,41
$\text{Cd}^{2+} + 2e^- \rightleftharpoons \text{Cd}$	-0,40
$\text{Co}^{2+} + 2e^- \rightleftharpoons \text{Co}$	-0,28
$\text{Ni}^{2+} + 2e^- \rightleftharpoons \text{Ni}$	-0,27
$\text{Sn}^{2+} + 2e^- \rightleftharpoons \text{Sn}$	-0,14
$\text{Pb}^{2+} + 2e^- \rightleftharpoons \text{Pb}$	-0,13
$\text{Fe}^{3+} + 3e^- \rightleftharpoons \text{Fe}$	-0,06
$2\text{H}^+ + 2e^- \rightleftharpoons \text{H}_2(\text{g})$	0,00
$\text{S} + 2\text{H}^+ + 2e^- \rightleftharpoons \text{H}_2\text{S}(\text{g})$	+0,14
$\text{Sn}^{4+} + 2e^- \rightleftharpoons \text{Sn}^{2+}$	+0,15
$\text{Cu}^{2+} + e^- \rightleftharpoons \text{Cu}^+$	+0,16
$\text{SO}_4^{2-} + 4\text{H}^+ + 2e^- \rightleftharpoons \text{SO}_2(\text{g}) + 2\text{H}_2\text{O}$	+0,17
$\text{Cu}^{2+} + 2e^- \rightleftharpoons \text{Cu}$	+0,34
$2\text{H}_2\text{O} + \text{O}_2 + 4e^- \rightleftharpoons 4\text{OH}^-$	+0,40
$\text{SO}_2 + 4\text{H}^+ + 4e^- \rightleftharpoons \text{S} + 2\text{H}_2\text{O}$	+0,45
$\text{Cu}^+ + e^- \rightleftharpoons \text{Cu}$	+0,52
$\text{I}_2 + 2e^- \rightleftharpoons 2\text{I}^-$	+0,54
$\text{O}_2(\text{g}) + 2\text{H}^+ + 2e^- \rightleftharpoons \text{H}_2\text{O}_2$	+0,68
$\text{Fe}^{3+} + e^- \rightleftharpoons \text{Fe}^{2+}$	+0,77
$\text{NO}_3^- + 2\text{H}^+ + e^- \rightleftharpoons \text{NO}_2(\text{g}) + \text{H}_2\text{O}$	+0,80
$\text{Ag}^+ + e^- \rightleftharpoons \text{Ag}$	+0,80
$\text{Hg}^{2+} + 2e^- \rightleftharpoons \text{Hg}(\ell)$	+0,85
$\text{NO}_3^- + 4\text{H}^+ + 3e^- \rightleftharpoons \text{NO}(\text{g}) + 2\text{H}_2\text{O}$	+0,96
$\text{Br}_2(\ell) + 2e^- \rightleftharpoons 2\text{Br}^-$	+1,07
$\text{Pt}^{2+} + 2e^- \rightleftharpoons \text{Pt}$	+1,20
$\text{MnO}_2 + 4\text{H}^+ + 2e^- \rightleftharpoons \text{Mn}^{2+} + 2\text{H}_2\text{O}$	+1,23
$\text{O}_2(\text{g}) + 4\text{H}^+ + 4e^- \rightleftharpoons 2\text{H}_2\text{O}$	+1,23
$\text{Cr}_2\text{O}_7^{2-} + 14\text{H}^+ + 6e^- \rightleftharpoons 2\text{Cr}^{3+} + 7\text{H}_2\text{O}$	+1,33
$\text{Cl}_2(\text{g}) + 2e^- \rightleftharpoons 2\text{Cl}^-$	+1,36
$\text{MnO}_4^- + 8\text{H}^+ + 5e^- \rightleftharpoons \text{Mn}^{2+} + 4\text{H}_2\text{O}$	+1,51
$\text{H}_2\text{O}_2 + 2\text{H}^+ + 2e^- \rightleftharpoons 2\text{H}_2\text{O}$	+1,77
$\text{Co}^{3+} + e^- \rightleftharpoons \text{Co}^{2+}$	+1,81
$\text{F}_2(\text{g}) + 2e^- \rightleftharpoons 2\text{F}^-$	+2,87

Increasing oxidising ability/*Toenemende oksiderende vermoë*

Increasing reducing ability/*Toenemende reduserende vermoë*



basic education

Department:
Basic Education
REPUBLIC OF SOUTH AFRICA

**NATIONAL
SENIOR CERTIFICATE/
NASIONALE
SENIOR SERTIFIKAAT**

GRADE/GRAAD 12

**PHYSICAL SCIENCES: CHEMISTRY (P2)
FISIESE WETENSKAPPE: CHEMIE (V2)**

NOVEMBER 2017

MARKING GUIDELINES/NASIENRIGLYNE

MARKS/PUNTE: 150

**These marking guidelines consist of 11 pages.
*Hierdie nasienriglyne bestaan uit 11 bladsye.***

QUESTION/VRAAG 1

- 1.1 D ✓✓ (2)
 1.2 B ✓✓ (2)
 1.3 C ✓✓ (2)
 1.4 A ✓✓ (2)
 1.5 C ✓✓ (2)
 1.6 C ✓✓ (2)
 1.7 C ✓✓ (2)
 1.8 A ✓✓ (2)
 1.9 B ✓✓ (2)
 1.10 B ✓✓ (2)
- [20]**

QUESTION/VRAAG 2

- 2.1
 2.1.1 Esters ✓ (1)
 2.1.2 Ethyl ✓ butanoate ✓ / *Etielbutanoaat* (2)
 2.1.3 Butanoic acid / *Butanoësuur* ✓ (1)

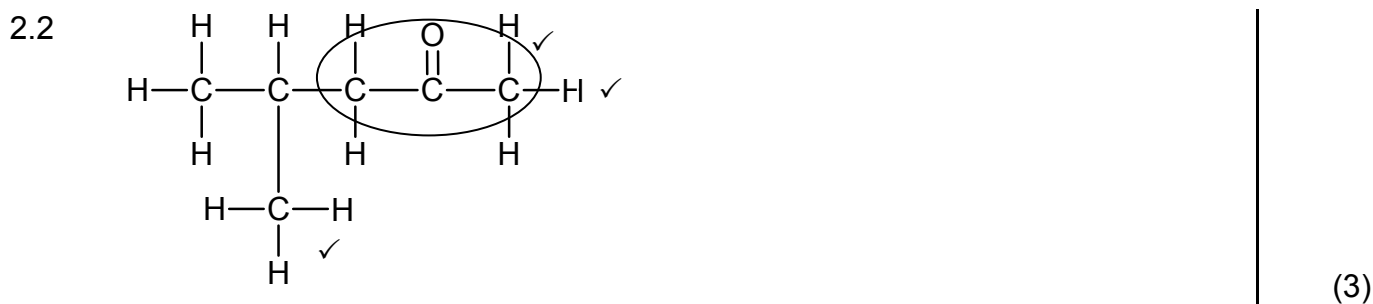
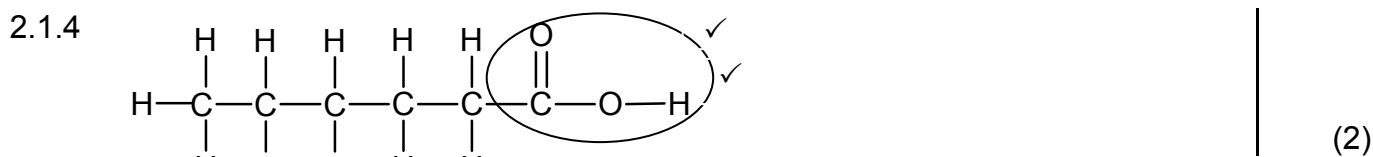

- 2.3
2.3.1 C_nH_{2n-2} ✓ (1)
- 2.3.2 5-ethyl-2,6-dimethylhept-3-yne/5-ethyl-2,6-dimethyl-3-heptyne
5-etiesel-2,6-dimetieselhept-3-yn/5-etiesel-2,6-dimetiesel-3-heptyn (3)

[13]

QUESTION/VRAAG 3

- 3.1 **ANY ONE/ENIGE EEN:**
- They have ONLY single bonds. ✓
Hulle het SLEGS enkelbindings.
 - They have single bonds between C atoms.
Hulle het enkelbindings tussen C-atome.
 - They have no double OR triple bonds OR multiple bonds.
Hulle het geen dubbel- OF trippelbindings OF meervoudige bindings nie.
 - They contain the maximum number of H atoms bonded to C atoms.
Hulle bevat die maksimum getal H-atome gebind aan C-atome.
 - Each C atom is bonded to four other atoms.
Elke C-atoom is gebind aan vier ander atome. (1)

- 3.2 The pressure exerted by a vapour in equilibrium with its liquid ✓ in a closed system. ✓
Die druk uitgeoefen deur 'n damp in ewewig met sy vloeistof in 'n geslote sisteem. (2)
-

- 3.3
3.3.1 Increases/Verhoog ✓ (1)

- 3.3.2 Q ✓
It is the temperature where the graph intercepts the dotted line. ✓
Dit is die temperatuur waar die grafiek die stippellyn sny.

OR/OF

It is the temperature where the vapour pressure of compound **Q** equals atmospheric pressure/is equal to 760 mmHg.

*Dit is die temperatuur waar die dampdruk van verbinding **Q** gelyk is aan atmosferiese druk/gelyk is aan 760 mmHg.* (2)

- 3.3.3 S ✓
- At a given temperature, **S** has the lowest vapour pressure/highest boiling point. ✓
*By 'n gegewe temperatuur het **S** die laagste dampdruk/hoogste kookpunt.*
 - Strongest intermolecular forces/London forces/dispersion forces/induced dipole forces. ✓
Sterkste intermolekulêre kragte/London-kragte/dispersiekragte/geïnduseerde dipoolkragte.
 - Highest energy needed to overcome/break the intermolecular forces. ✓
Hoogste energie benodig om intermolekulêre kragte te oorkom/breek. (4)

3.4
3.4.1

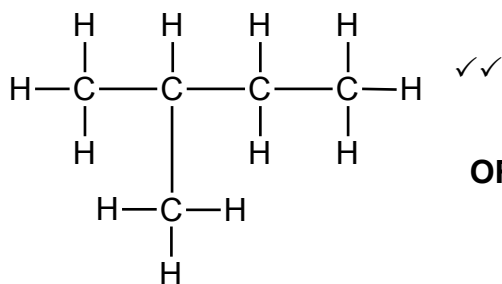

2-methylbutane ✓
2-metielbutaan

OR/OF

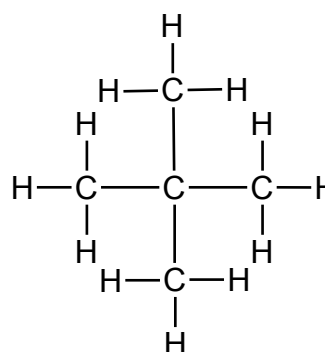

2,2-dimethylpropane ✓
2,2-dimetielpropaan

(3)

3.4.2 Higher than/Hoër as ✓

(1)

[14]

QUESTION/VRAAG 4

4.1 Secondary/Sekondêre ✓

The C atom bonded to the –OH group is bonded to TWO other C atoms. ✓
Die C-atoom gebind aan die –OH-groep is aan TWEE ander C-atome gebind.

(2)

4.2

4.2.1 Dehydration ✓

Dehidrasie/dehidratering

(1)

4.2.2 Hydration ✓

Hidrasie/hidratering

(1)

4.2.3 Dehydrohalogenation/dehydrobromination ✓

Dehidrohalogenasie/dehidrohalogenering/dehidrobrominasie/
dehidrobrominerig

(1)

4.3

4.3.1 Substitution/Hydrolysis ✓

Substitusie/Hidrolise

(1)

4.3.2 • Dilute base/sodium hydroxide/NaOH ✓

Verdunde basis/natriumhidroksied/NaOH

• Moderate temperature/(mild) heat ✓

Matige temperatuur/(matige) hitte

(2)

4.3.3 2-✓bromobutane ✓/2-bromobutaan

(2)

4.4 NaOH/KOH ✓

(1)

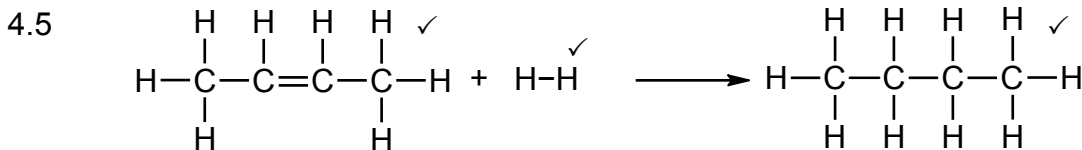

(3)

4.6 Butane/Butaan

(1)

[15]

QUESTION/VRAAG 5

5.1 **ANY ONE/ENIGE EEN:**

- Change in concentration of products/reactants per (unit) time. ✓✓
Verandering in konsentrasie van produkte/reaktanse per (eenheid) tyd.
- Rate of change in concentration.
Tempo van verandering in konsentrasie.
- Change in amount/number of moles/volume/mass of products or reactants per (unit) time.
Verandering in hoeveelheid/getal mol/volume/massa van produkte of reaktanse per (eenheid) tyd.
- Amount/number of moles/volume/mass of products formed or reactants used per (unit) time.
Hoeveelheid/getal mol/volume/massa van produkte gevorm of reaktanse gebruik per (eenheid) tyd.

(2)

5.2

Marking criteria/Nasienriglyne:	
Dependent and independent variables correctly identified. <i>Afhanklike en onafhanklike veranderlikes korrek geïdentifiseer.</i>	✓
Ask a question about the relationship between the independent and dependent variables./Vra 'n vraag oor die verwantskap tussen die afhanklike en onafhanklike veranderlikes.	✓

Examples/Voorbeelde:

- What is the relationship between concentration and reaction rate?
Wat is die verwantskap tussen konsentrasie en reaksietempo?
- How does the reaction rate change when the concentration changes/increases/decreases?
Hoe sal die reaksietempo verander wanneer die konsentrasie verander/verhoog/verlaag?

(2)

5.3 Q ✓

- Smaller gradient./Less steep. ✓
Kleiner gradiënt./Minder steil.
- Reaction **I** has the lowest HCl concentration and will take longer to reach completion/for the maximum volume of gas to be formed. ✓
*Reaksie **I** het die laagste HCl-konsentrasie en neem langer om voltooi te word/die maksimum volume gas te vorm.*

(3)

5.4

<p>OPTION 1/OPSIE 1</p> <p>Ave rate/Gem. tempo = $\frac{\Delta V}{\Delta t}$</p> <p>$15 = \frac{\Delta V}{30 - 0}$ ✓</p> <p>$V(\text{H}_2)_{\text{produced/berei}} = 450 \text{ cm}^3$</p> <p>$n(\text{H}_2)_{\text{produced/berei}} = \frac{V}{V_m}$</p> <p>$= \frac{450}{24\,000}$ ✓</p> <p>$= 0,0188 \text{ mol}$</p> <p>$n(\text{Zn}) = n(\text{H}_2) = 0,0188 \text{ mol}$ ✓</p> <p>$n(\text{Zn})_{\text{used/gebruik}} = \frac{m}{M}$</p> <p>$\therefore 0,0188 = \frac{m}{65}$ ✓</p> <p>$\therefore m(\text{Zn}) = 1,22 \text{ g}$ ✓</p>	<p>OPTION 2/OPSIE 2</p> <p>Ave rate/Gem. tempo = $\frac{15}{24\,000}$ ✓</p> <p>$= 6,25 \times 10^{-4} \text{ mol}\cdot\text{s}^{-1}$</p> <p>$V(\text{H}_2)_{\text{produced/berei}} = 6,25 \times 30$ ✓</p> <p>$= 0,0188 \text{ mol}$</p> <p>$n(\text{Zn}) = n(\text{H}_2) = 0,0188 \text{ mol}$ ✓</p> <p>$n(\text{Zn})_{\text{used}} = \frac{m}{M}$</p> <p>$0,0188 = \frac{m}{65}$ ✓</p> <p>$\therefore m(\text{Zn}) = 1,22 \text{ g}$ ✓</p> <p>OPTION 3/OPSIE 3</p> <p>Ave rate/Gem. tempo = $\frac{\Delta V}{\Delta t}$</p> <p>$15 = \frac{\Delta V}{30 - 0}$ ✓</p> <p>$V(\text{H}_2)_{\text{produced/berei}} = 450 \text{ cm}^3$</p> <p>65 g ✓ Zn 24 000 cm³ ✓</p> <p>x g Zn 450 cm³ ✓</p> <p>x = 1,22 g ✓</p>
--	--

(5)

5.5

5.5.1 Equal to/Gelyk aan ✓

(1)

5.5.2 Equal to/Gelyk aan ✓

(1)

5.6

- At higher temperature the average kinetic energy of particles is higher. ✓
By hoër temperatuur is die gemiddelde kinetiese energie van deeltjies hoër.
- More molecules gain sufficient/enough kinetic energy OR more molecules have kinetic energy equal to or greater than the activation energy. ✓
Meer molekule het voldoende/genoeg kinetiese energie OF meer molekule het kinetiese energie gelyk aan of groter as die aktiveringsenergie.
- More effective collisions per unit time./Frequency of effective collisions increases. ✓
Meer effektiewe botsings per eenheidtyd./Frekwensie van effektiewe botsings neem toe.

(3)

[17]

QUESTION/VRAAG 6

6.1 The stage in a chemical reaction when the rate of forward reaction equals the rate of reverse reaction. ✓✓

Die stadium in 'n chemiese reaksie wanneer die tempo van die voorwaartse reaksie gelyk is aan die tempo van die terugwaartse reaksie.

OR/OF

The stage in a chemical reaction when the concentrations of reactants and products remain constant. ✓✓

Die stadium in 'n chemiese reaksie wanneer die konsentrasies van reaktanse en produkte konstant bly.

(2)

6.2

6.2.1

OPTION 1/OPSIE 1

$$n = \frac{m}{M}$$

$$= \frac{1,12}{28} \checkmark$$

$$= 0,04 \text{ mol}$$

	COBr ₂	CO	Br ₂
Initial quantity (mol) <i>Aanvangshoeveelheid (mol)</i>		0	0
Change (mol) <i>Verandering (mol)</i>	0,04	0,04	0,04
Quantity at equilibrium (mol)/ <i>Hoeveelheid by ewewig (mol)</i>		0,04	0,04 ✓
Equilibrium concentration/ <i>Ewewigskonsentrasie (mol·dm⁻³)</i>		0,02	0,02

Divide by 2 ✓
Deel deur 2

$$K_c = \frac{[\text{CO}][\text{Br}_2]}{[\text{COBr}_2]} \checkmark$$

$$0,19 \checkmark = \frac{(0,02)^2}{[\text{COBr}_2]} \checkmark$$

$$[\text{COBr}_2] = 2,11 \times 10^{-3} \text{ mol·dm}^{-3} \checkmark$$

OPTION 2/OPSIE 2

$$n = \frac{m}{M}$$

$$= \frac{1,2}{28} \checkmark$$

$$= 0,04 \text{ mol}$$

$$n(\text{CO})_{\text{formed/gevorm}} = n(\text{Br}_2)_{\text{formed/gevorm}} \checkmark$$

$$= 0,04 \text{ mol}$$

$$c(\text{CO})_{\text{eq/ewe}} = c(\text{Br}_2)_{\text{eq/ewe}}$$

$$= \frac{n}{V}$$

$$= \frac{0,04}{2} \checkmark$$

$$= 0,02 \text{ mol} \cdot \text{dm}^{-3}$$

$$K_c = \frac{[\text{CO}][\text{Br}_2]}{[\text{COBr}_2]} \checkmark$$

$$0,19 \checkmark = \frac{(0,2)^2}{[\text{COBr}_2]} \checkmark$$

$$[\text{COBr}_2] = 2,11 \times 10^{-3} \text{ mol} \cdot \text{dm}^{-3} \checkmark$$

(7)

6.2.2

OPTION 1/OPSIE 1

$$n(\text{COBr}_2)_{\text{eq/ewewig}} = cV$$

$$= 2,11 \times 10^{-3} \times 2 \checkmark$$

$$= 4,22 \times 10^{-3} \text{ mol}$$

$$n(\text{COBr}_2)_{\text{initial/begin}} \swarrow$$

$$= 0,04 + 4,22 \times 10^{-3} \checkmark$$

$$= 0,044 \text{ mol}$$

$$\% \text{ decomposed} = \frac{0,04 \checkmark}{0,044} \times 100$$

$$= 90,46\% \checkmark$$

Range/Gebied: 90,46 – 90,9%

OPTION 2/OPSIE 2

$$n(\text{COBr}_2)_{\text{eq/ewewig}} = cV$$

$$= 2,11 \times 10^{-3} \times 2 \checkmark$$

$$= 4,22 \times 10^{-3} \text{ mol}$$

$$n(\text{COBr}_2)_{\text{initial/begin}} \swarrow$$

$$= 0,04 + 4,22 \times 10^{-3} \checkmark$$

$$= 0,044 \text{ mol}$$

$$m(\text{COBr}_2)_{\text{initial/begin}} = nM$$

$$= 0,044 \times 188$$

$$= 8,27 \text{ g}$$

$$m(\text{COBr}_2)_{\text{reacted/reageer}} = 0,04 \times 188$$

$$= 7,52 \text{ g}$$

$$\% \text{ decomposed/ontbind} = \frac{7,52 \checkmark}{8,27} \times 100$$

$$= 90,9\% \checkmark$$

(4)

6.3 $K_c < 0,19$

(1)

6.4 Decreases/Verminder \checkmark

A decreases in pressure favours the reaction that produces the larger number of moles of gas. /'n Afname in druk bevoordeel die reaksie wat die groter aantal mol gas lewer. \checkmark

The forward reaction will be favoured. /Die voorwaartse reaksie sal bevoordeel word. \checkmark

(3)

[17]

QUESTION/VRAAG 7

7.1

7.1.1 Weak/Swak ✓
 Dissociates/Ionises incompletely (in water) ✓
 Dissosieer/Ioniseer onvolledig (in water) (2)

7.1.2 NH₄⁺ ✓ (1)

7.1.3 H₂O/water **OR/OF** NH₃ ✓ (1)

7.2

7.2.1 Acidic/Suur ✓
 pH < 7 ✓ (2)

7.2.2	<p>OPTION 1/OPSIE 1</p> <p>pH = -log[H₃O⁺] ✓ 6 ✓ = -log[H₃O⁺] [H₃O⁺] = 1 × 10⁻⁶ mol·dm⁻³</p> <p>[H₃O⁺][OH⁻] = 10⁻¹⁴ ✓ [OH⁻] = 1 × 10⁻⁸ mol·dm⁻³ ✓</p>	<p>OPTION 2/OPSIE 2</p> <p>pH + pOH = 14 ✓ 6 ✓ + pOH = 14</p> <p>pOH = -log[OH⁻] ✓ 8 = -log[OH⁻] [OH⁻] = 1 × 10⁻⁸ mol·dm⁻³ ✓</p>	(4)
-------	--	---	-----

7.3

<p>OPTION 1/OPSIE 1</p> <p>$n(\text{Na}_2\text{CO}_3) = \frac{m}{M}$ ✓ $= \frac{0,29}{106}$ ✓ $= 2,74 \times 10^{-3} \text{ mol}$</p> <p>$n(\text{HCl}) = 2n(\text{Na}_2\text{CO}_3)$ ✓ $= 5,47 \times 10^{-3} \text{ mol}$</p> <p>$c(\text{HCl})_{\text{dilute/verduun}} = \frac{n}{V}$ $= \frac{5,47 \times 10^{-3}}{0,05}$ ✓ $= 0,1094 \text{ mol} \cdot \text{dm}^{-3}$</p> <p>$cV(\text{HCl})_{\text{dilute/verduun}} = cV(\text{HCl})_{\text{concl/gekons}}$ $0,1094 \times 500$ ✓ $= (\text{HCl})_{\text{concl/gekons}} \times 5$ ✓ $\therefore c(\text{HCl})_{\text{concl/gekons}} = 10,94 \text{ mol} \cdot \text{dm}^{-3}$ ✓</p>	<p>OPTION 2/OPSIE 2</p> <p>$n(\text{Na}_2\text{CO}_3) = \frac{m}{M}$ ✓ $= \frac{0,29}{106}$ ✓ $= 2,74 \times 10^{-3} \text{ mol}$</p> <p>$n(\text{HCl}) = 2n(\text{Na}_2\text{CO}_3)$ ✓ $= 5,47 \times 10^{-3} \text{ mol}$</p> <p>In 50 cm³: $n(\text{HCl}) = 5,47 \times 10^{-3} \text{ mol}$ In 500 cm³: $n(\text{HCl}) = \frac{500}{50} (5,47 \times 10^{-3})$ ✓ $= 0,547 \text{ mol}$</p> <p>$c(\text{HCl})_{\text{concl/gekons}} = 0,547 \times \frac{1000}{5}$ ✓ $= 10,94 \text{ mol} \cdot \text{dm}^{-3}$ ✓</p>
--	---

(7)
[17]

QUESTION/VRAAG 8

8.

8.1.1 Voltmeter/Multimeter ✓ (1)

8.1.2 Anode ✓ (1)

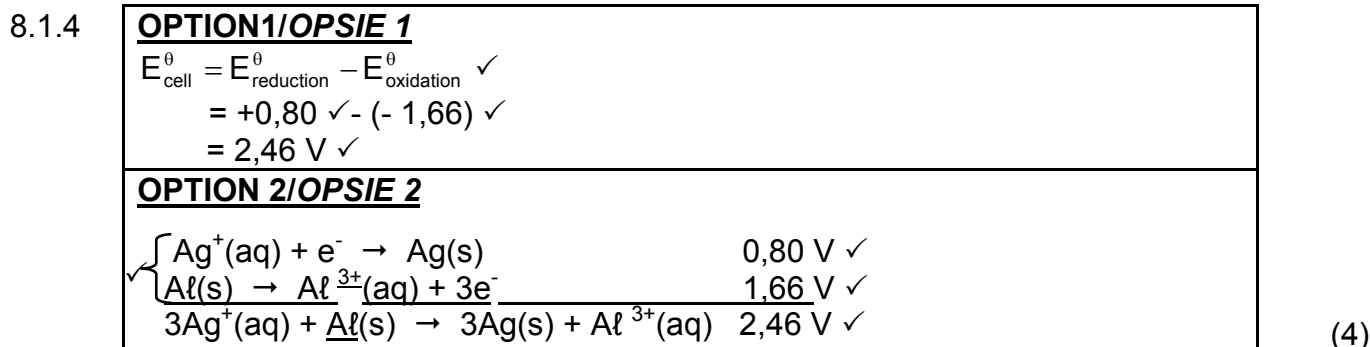
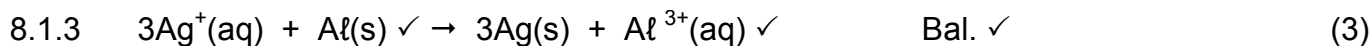

8.2
 8.2.1 Platinum/Pt/Carbon/C/Koolstof \checkmark (1)

8.2.2 **ANY TWO/ENIGE TWEE:**
 Concentration/Konsentrasie: $1 \text{ mol}\cdot\text{dm}^{-3} \checkmark$
 Temperature/Temperatuur: $25 \text{ }^{\circ}\text{C}/298 \text{ K} \checkmark$
 Pressure/Druk: $101,3 \text{ kPa}/1,01 \times 10^5 \text{ Pa}/1 \text{ atm}$ (2)

8.2.3 Zinc/Zn/sink \checkmark (1)

8.2.4 PQ \checkmark (1)
[14]

QUESTION/VRAAG 9

9.1 DC \checkmark (1)

9.2 Cathode/Katode \checkmark
 $\text{Cu}^{2+}(\text{aq}) + 2\text{e}^- \rightarrow \text{Cu} \checkmark\checkmark$

9.3 Cu^{2+} is a stronger oxidising agent \checkmark than Zn^{2+} ions \checkmark and therefore Zn^{2+} ions will not be reduced (to Zn). \checkmark
 Cu^{2+} is 'n sterker oksideermiddel as Zn^{2+} -ione en dus sal Zn^{2+} -ione nie gereduseer word nie (na Zn). (3)

9.4
 9.4.1 (Chlorine) gas/bubbles is/are formed. \checkmark
(Chloor)gas/borrels vorm. (1)

9.4.2 Decreases/Verlaag \checkmark (1)
[9]

QUESTION 10/VRAAG 10

10.1

10.1.1 Ammonia/Ammoniak ✓ (1)

10.1.2 NO₂ ✓ (1)

10.1.3 Catalytic oxidation of ammonia ✓
Katalitiese oksidasie van ammoniak (1)

10.1.4 Platinum/Pt ✓ (1)

10.1.5 Ostwald (process)/Ostwald(proses)✓ (1)

10.1.6 Haber (process)/Haber(proses)✓ (1)

10.1.7 NH₃ + HNO₃ ✓ → NH₄NO₃ ✓ Bal. ✓ (3)

10.2

10.2.1	<u>OPTION 1/OPSIE 1</u> N : P : K 10 : 5 : 15 $m(\text{fertiliser/kunsmis}) = \frac{30}{100} \times 15$ $= 4,5 \text{ kg}$ $m(\text{P}) = \frac{5}{30} \times 4,5 \checkmark$ $= 0,75 \text{ kg} \checkmark$	<u>OPTION 2/OPSIE 2</u> $m(\text{fertiliser/kunsmis}) = \frac{5}{100} \times 15 \checkmark$ $= 0,75 \text{ kg} \checkmark$	(2)
--------	---	---	-----

10.2.2 %fertiliser/kunsmis = 10 + 5 + 15 = 30%

%filler/bindstof = 100 – 30 = 70%

$m(\text{filler/bindstof}) = \frac{70}{100} \checkmark \times 15 \checkmark$
 $= 10,5 \text{ kg} \checkmark$ (3)

[14]

TOTAL/TOTAAL: 150